

Jazzy 1103 Ultra

Owner's Manual



How a Power Chair Should Feel!™

Pride
Mobility Products Corp.

Exeter, PA
St. Catharines, ON

1-800-800-8586

www.pridemobility.com

SAFETY GUIDELINES

The symbols below are used throughout this owner's manual and on the power chair to identify warnings and important information. It is very important for you to read them and understand them completely.



WARNING! Failure to follow designated procedures can cause either personal injury, component damage, or malfunction (black symbol on yellow triangle with black border).



MANDATORY! These actions should be performed as specified. Failure to perform mandatory actions can cause injury to personnel and/or damage to equipment (white symbol on blue dot with white border).



PROHIBITED! These actions are prohibited. These actions should not be performed at any time or in any circumstances. Performing a prohibited action can cause injury to personnel and/or damage to equipment (black symbol with red circle and red slash).

C O N T E N T S

I. INTRODUCTION.....	4
II. SAFETY	6
III. YOUR POWER CHAIR	16
IV. ASSEMBLY.....	21
V. COMFORT ADJUSTMENTS.....	23
VI. BATTERIES AND CHARGING	31
VII. OPERATION.....	35
VIII. CARE AND MAINTENANCE	47
IX. WARRANTY	53

This owner’s manual is compiled from the latest specifications and product information available at the time of publication. We reserve the right to make changes as they become necessary. Any changes to our products may cause slight variations between the illustrations and explanations in this manual and the product you have purchased.

I . I N T R O D U C T I O N

SAFETY

WELCOME to Pride Mobility Products Corporation (Pride). The power chair you have purchased combines state-of-the-art components with **safety**, comfort, and styling in mind. We are confident that these design features will provide you with the conveniences you expect during your daily activities. Once you understand how to **safely** operate and care for your power chair, it should give you years of trouble free operation and service.

Read and follow all instructions, warnings, and notes in this manual before attempting to operate your power chair for the first time. In addition, your **safety** depends upon you, as well as your provider, caretaker, or healthcare professional in using good judgement.

If there is any information in this manual which you do not understand, or if you require additional assistance for setup or operation, please contact your authorized Pride Provider. **Failure to follow the instructions in this manual and those located on your power chair can lead to personal injury and/or damage to the power chair, including voiding the warranty.**

PURCHASER'S AGREEMENT

By accepting delivery of this product, you promise that you will not change, alter, or modify this product or remove or render inoperable or unsafe any guards, shields, or other safety features of this product; fail, refuse, or neglect to install any retrofit kits from time to time provided by Pride to enhance or preserve the safe use of this product.

INFORMATION EXCHANGE

We want to hear your questions, comments, and suggestions about this manual. We would also like to hear about the safety and reliability of your new power chair, and about the service you received from your authorized Pride Provider.

Please notify us of any change of address, so we can keep you apprised of important information about safety, new products, and new options that can increase your ability to use and enjoy your power chair. Please feel free to contact us at the address below:

Pride Mobility Products Corporation
Attn: Customer Care Department
182 Susquehanna Avenue
Exeter, PA 18643-2694
customercare@pridemobility.com
800-424-8205

NOTE: If you ever lose or misplace your product registration card or your copy of this manual, contact us and we will be glad to send you a new one immediately.

I . I N T R O D U C T I O N

PRIDE OWNERS CLUB

As an owner of a Pride product, you are invited to register your product's warranty and enroll in the Pride Owners Club. You may do so by filling out and returning your enclosed product registration card or by visiting Pride's web site at www.pridemobility.com. As a registered member, each time you visit our site, you will have access to the most interactive and honest educational venue available today for people with mobility needs, their families, and friends.

From our home page, select "Owners Club" to enter a page dedicated to current and potential Pride product owners. You will gain access to interviews, stories, recreation ideas, daily living tips, product and funding information, and interactive message boards. These message boards invite you to communicate with other Pride customers as well as Pride representatives who are available to assist you with any questions or concerns you may have.

My Authorized Pride Provider:

Name: _____

Address: _____

Phone Number: _____

Purchase Date: _____

II. SAFETY

PRODUCT SAFETY SYMBOLS

The symbols below are used on the power chair to identify warnings, mandatory actions, and prohibited actions. It is very important for you to read and understand them completely.



Corrosive chemicals contained in battery. Use only AGM or Gel-Cell batteries to reduce the risk of leakage or explosive conditions.



This product has been tested and passed at an immunity level of 20 V/m.



Read and follow the information in the owner's manual.



Maximum seating weight.



Locked and in drive mode.

Place unit on level ground and stand behind or to one side when changing from drive mode to freewheel mode or freewheel mode to drive mode.

Unlocked and in freewheel mode.

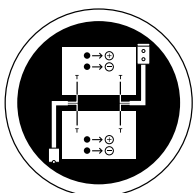

Battery Configuration:

T = Terminal Post

Connect Red wire to T with +

Connect Black wire to T with -

II. SAFETY



Do not remove anti-tip wheels.



Do not use a cell phone, walkie/talkie, laptop, or other radio transmitter while operating.



Avoid exposure to rain, snow, ice, salt, or standing water whenever possible. Maintain and store in a clean and dry condition.



Removal of grounding prong can create electrical hazard. If necessary, properly install an approved 3-pronged adapter to an electrical outlet having 2-pronged plug access. Failure to heed could result in personal injury and/or property damage.

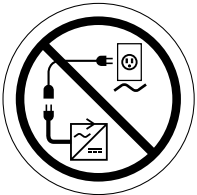

Prevent personal injury and equipment damage. Do not connect an extension cord to the AC/DC converter or the battery charger.

II. SAFETY

SAFETY



MANDATORY! Do not operate your new power chair for the first time without completely reading and understanding this owner's manual.

Your power chair is a state-of-the-art life-enhancement device designed to increase mobility. Pride provides an extensive variety of products to best fit the individual needs of the power chair user. Please be aware that the final selection and purchasing decision regarding the type of power chair to be used is the responsibility of the power chair user, who is capable of making such a decision, and his/her healthcare professional (i.e., medical doctor, physical therapist, etc.).

The contents of this manual are based on the expectation that a mobility device expert has properly fitted the power chair to the user and has assisted the prescribing healthcare professional and/or the authorized Pride Provider in the instruction process for the use of the product.

There are certain situations, including some medical conditions, where the power chair user will need to practice operating the power chair in the presence of a trained attendant. A trained attendant can be defined as a family member or care professional specially trained in assisting a power chair user in various daily living activities.

As you begin using your power chair during daily activities, you will probably encounter situations in which you will need some practice. Simply take your time and you will soon be in full and confident control as you maneuver through doorways, on and off of elevators, up and down ramps, and over moderate terrain.

Below are some precautions, tips, and other safety considerations that will help the user become accustomed to operating the power chair safely.

Modifications

Pride has designed and engineered your power chair to provide maximum mobility and utility. A wide range of accessories is available from your authorized Pride Provider to further customize your power chair to better suit your needs and/or preferences. However, under no circumstances should you modify, add, remove, or disable any feature, part, or function of your power chair.



WARNING! Do not modify your power chair in any way not authorized by Pride. Unauthorized modifications may result in personal injury and/or damage to your power chair.

Pre-Ride Safety Check

Get to know the feel of your power chair and its capabilities. Pride recommends that you perform a safety check before each use to make sure your power chair operates smoothly and safely. See VIII. "Care and Maintenance."

Perform the following inspections prior to using your power chair:

- Check for proper tire inflation. Maintain but do not exceed **35 psi (2.4 bar)** in each tire (if equipped with pneumatic tires).
- Check all electrical connections. Make sure they are tight and not corroded.
- Check all controller connections to the power pod. Make sure they are secured properly.
- Check the brakes. See VIII. "Care and Maintenance."
- Check battery charge. See VI. "Batteries and Charging."

NOTE: *If you discover a problem, contact your authorized Pride Provider for assistance.*

II. SAFETY

Weight Limitations

Your power chair is rated for a maximum weight capacity. Please refer to the specifications table for this limit.



WARNING! Exceeding the weight capacity voids your warranty and may result in personal injury and/or damage to your power chair. Pride will not be held responsible for injuries and/or property damage resulting from failure to observe weight limitations.

WARNING! Do not carry passengers on your power chair. Carrying passengers on your power chair may result in personal injury and/or property damage.

Tire Inflation

If your power chair is equipped with pneumatic tires, you should check or have the air pressure checked regularly. Proper inflation pressures will prolong the life of your tires and help ensure the smooth operation of your power chair.



WARNING! It is important that 35 psi (2.4 bar) tire pressure be maintained in pneumatic tires at all times. Do not underinflate or overinflate your tires. Low pressure may result in loss of control, and overinflated tires may burst. Failure to maintain 35 psi (2.4 bar) tire pressure in pneumatic tires at all times may result in tire and/or wheel failure, causing serious personal injury and/or damage to your power chair.

WARNING! Inflate your power chair drive tires from a regulated air source with an available pressure gauge. Inflating your tires from an unregulated air source could overinflate them, resulting in a burst tire and/or personal injury.

Incline Information

More and more buildings have ramps with specified degrees of inclination, designed for easy and safe access. Some ramps may have turning switchbacks (180-degree turns) that require you to have good cornering skills on your power chair.

- Proceed with extreme caution as you approach the downgrade of a ramp or other incline.
- Take wide swings with your power chair's front wheels around any tight corners. If you do that, the power chair's rear wheels will follow a wide arc, not cut the corner short, and not bump into or get hung up on any railing corners.
- When driving down a ramp, keep the power chair's speed adjustment set to the slowest speed setting to ensure a safely controlled descent. See VII. "Operation."
- Avoid sudden stops and starts.

When climbing an incline, try to keep your power chair moving. If you must stop, start up again slowly and then accelerate cautiously. When driving down an incline, set your power chair to the slowest setting and drive in the forward direction only. If your power chair starts to move down the incline faster than you anticipated or desired, allow it to come to a complete stop by releasing the joystick, then push the joystick forward slightly to ensure a safely controlled descent.

WARNING! When climbing an incline, do not zigzag or drive at an angle up the face of the incline. Drive your power chair straight up the incline. This greatly reduces the possibility of a tip or a fall. Always exercise extreme caution when negotiating an incline.



WARNING! You should not travel up or down a potentially hazardous incline (i.e., areas covered with snow, ice, cut grass, or wet leaves).

WARNING! When on any sort of an incline or decline, never place the power chair in freewheel mode while seated on it or standing next to it. Doing so may result in personal injury and/or damage to your power chair.

WARNING! Never travel down an incline backwards. This may result in personal injury.

II. SAFETY



WARNING! Even though your power chair is capable of climbing slopes greater than those illustrated in figure 1, do not, under any circumstances, exceed the incline guidelines or any other specifications presented in this manual. Doing so could cause instability in your power chair, resulting in personal injury and/or damage to your power chair.

In compliance with the Americans with Disabilities Act of 1990, all handicap public access ramps are required to have a maximum slope of 5° (8.7%). Therefore, Pride recommends that the maximum slope of an incline you attempt to safely ascend or descend on your power chair does not exceed 5° (8.7%). See figure 1.



WARNING! Any attempt to climb or descend a slope steeper than 5°(8.7%) may put your power chair in an unstable position and cause it to tip, resulting in personal injury

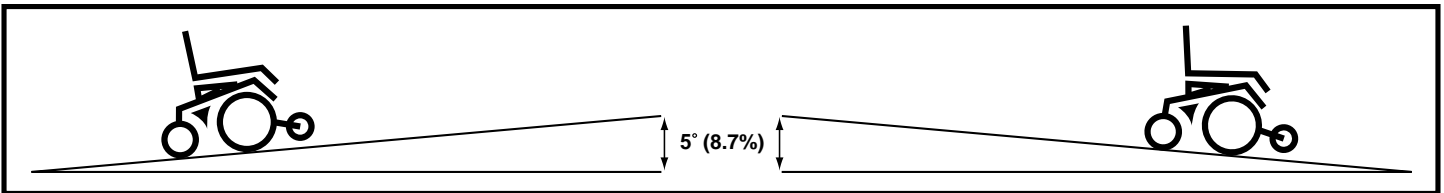

Figure 1. Maximum Safe Slope (Ascending and Descending)

Braking Information

Your power chair is equipped with two powerful brake systems:

1. Regenerative — uses electricity to rapidly slow the vehicle when the joystick returns to the center/stop position.
2. Disc Park Brake — activates mechanically after regenerative braking slows the vehicle to near stop, or when power is removed from the system for any reason.

Cornering Information

While your power chair is equipped with caster wheels and anti-tip wheels, excessively high cornering speeds can still create the possibility of tipping. Factors which affect the possibility of tipping include, but are not limited to: cornering speed, steering angle (how sharply you are turning), uneven road surfaces, inclined road surfaces, riding from an area of low traction to an area of high traction (such as passing from a grassy area to a paved area – especially at high speed while turning), and abrupt directional changes. High cornering speeds are not recommended. If you feel that you may tip over in a corner, reduce your speed and steering angle (i.e., lessen the sharpness of the turn) to prevent your power chair from tipping.



WARNING! When cornering sharply, reduce your speed. This greatly reduces the possibility of a tip or fall. To avoid personal injury and/or property damage, always exercise common sense when cornering.

Public Streets and Roadways



WARNING! You should not operate your power chair on public streets and roadways. Be aware that it may be difficult for traffic to see you when you are seated on your power chair. Obey all local pedestrian traffic rules. Wait until your path is clear of traffic, and then proceed with extreme caution.

Freewheel Mode

Your power chair is equipped with two manual freewheel levers to allow for manual maneuverability by a trained attendant. For more information about how to place your power chair into and out of freewheel mode, see III. “Your Power Chair.”

II. SAFETY

WARNING! Do not use your power chair in freewheel mode without an attendant present. Personal injury may result.



WARNING! Do not attempt to personally place your power chair in freewheel mode while seated on it. Personal injury may result. Ask an attendant for assistance if necessary.

WARNING! Do not place your power chair in freewheel mode while on an incline. The chair could roll uncontrollably on its own, causing personal injury.

Outdoor Driving Surfaces

Your power chair is designed to provide optimum stability under normal driving conditions—dry, level surfaces composed of concrete, blacktop, or asphalt. However, Pride recognizes that there will be times when you will encounter other surface types. For this reason, your power chair is designed to perform admirably on packed soil, grass, and gravel. Feel free to use your power chair safely on lawns and in park areas.

- Reduce your power chair's speed when driving on uneven terrain and/or soft surfaces.
- Avoid tall grass that can entangle the running gear.
- Avoid loosely packed gravel and sand.
- If you feel unsure about a driving surface, avoid that surface.

Stationary Obstacles (Steps, Curbs, etc.)

Proceed with extreme caution when driving near raised surfaces, unprotected ledges and/or drop-offs (curbs, porches, stairs, etc.). The correct method for approaching a curb is illustrated in figure 2.

WARNING! Do not attempt to have your power chair climb or descend an obstacle that is higher than two inches unless you have the assistance of an attendant.



WARNING! Do not attempt to have your power chair proceed backward down any step, curb, or other obstacle. This may cause the power chair to tip and cause personal injury.

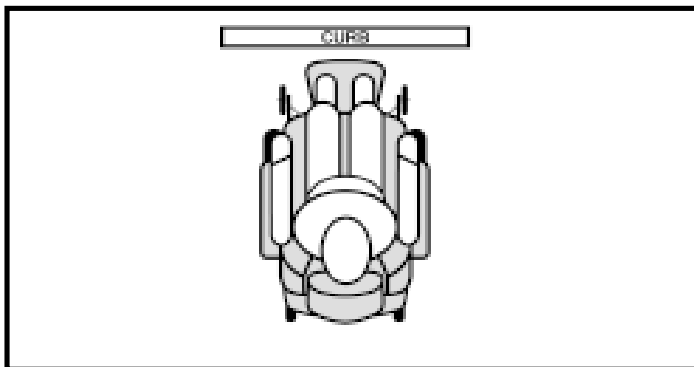

Figure 2. Correct Curb Approach

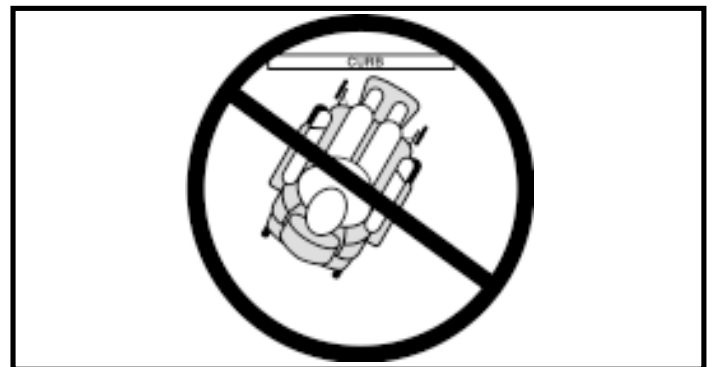

Figure 3. Incorrect Curb Approach

Stairs and Escalators

Power chairs are not designed to travel up or down stairs or escalators. Always use an elevator.



WARNING! Never use your power chair to negotiate steps or escalators. You may cause injury to yourself and to others and/or damage your power chair.

II. SAFETY

Transfers

Transferring onto and off of your power chair requires a good sense of balance. Always have an attendant or healthcare professional present while learning to properly transfer yourself.

To eliminate the possibility of injury, Pride recommends that you or a trained attendant perform the following tasks before attempting a transfer:

- Turn off the power to the controller. See VII. "Operation."
- Ensure your power chair is not in freewheel mode. See III. "Your Power Chair."
- Turn both caster wheels toward the transfer destination to improve power chair stability during transfer.
- Make sure both armrests are flipped up or removed from your power chair.
- Flip up the foot platform or move the leg rests aside; this will help to keep your feet from getting caught on the foot rigging during the transfer.
- Reduce the distance between your power chair and the object you are transferring onto.

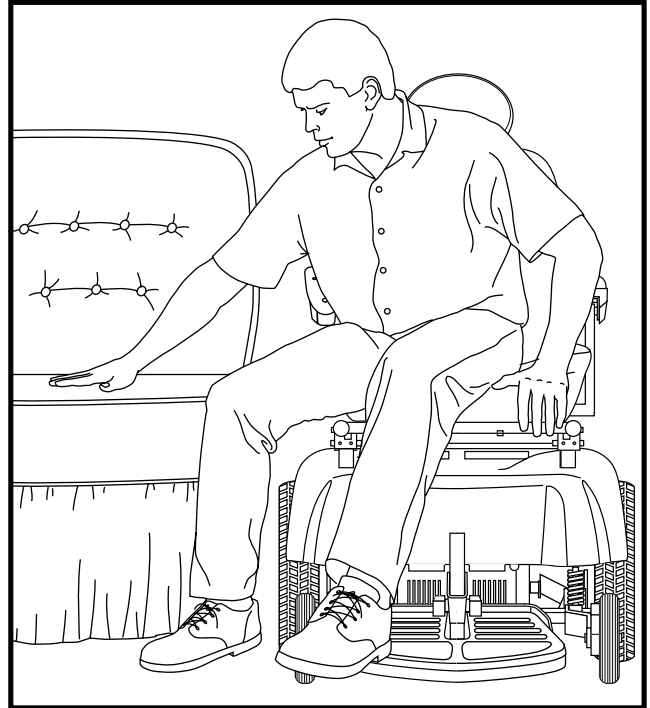

Figure 4. Ideal Transfer Position

WARNING! Before transferring, position yourself as far back as possible in the power chair seat to prevent the power chair from tipping forward during transfer and causing injury.



WARNING! Avoid using your armrests for weight bearing purposes. Such use may cause the power chair to tip and cause personal injury.

WARNING! Avoid putting all of your weight on the foot rigging. Such use may cause the power chair to tip and cause personal injury.

Motor Vehicle Transport

Pride recommends that you do not remain seated in your power chair while traveling in a motor vehicle. The power chair should be stowed in the trunk of a car or in the back of a truck or van with batteries removed and properly secured.



WARNING! Do not sit on your power chair while it is in a moving vehicle. Personal injury and/or property damage may result.

WARNING! Always be sure your power chair and its batteries are properly secured when it is being transported. Failure to do so may result in personal injury and/or damage to your power chair.

Doors

- Determine if the door opens toward or away from you.
- Drive your power chair gently and slowly forward to push the door open. Or drive your power chair gently and slowly backward to pull the door open.

II. SAFETY

Elevators

Modern elevators have a door edge safety mechanism that, when pushed, reopens the elevator door(s).

- If you are in the doorway of an elevator when the door(s) begin to close, push on the rubber door edge or allow the rubber door edge to contact the power chair and the door will reopen.
- Use care that pocketbooks, packages, or power chair accessories do not become caught in elevator doors.

Lift/Elevation Products

If you will be traveling with your power chair, you may find it necessary to use a lift/elevation product to aid in transportation. Pride recommends that you closely review the instructions, specifications, and safety information set forth by the manufacturer of the lift/elevation product before using that product.

Inclement Weather Precautions

Exposure of your power chair to inclement weather conditions should be avoided whenever possible. If suddenly caught up in rain, snow, severe cold, or heat while operating your power chair proceed to shelter at the earliest opportunity. Thoroughly dry your power chair before storing, charging, or operating your power chair.



WARNING! Operating in rain, snow, salt, mist/spray conditions, and on icy/slippery surfaces can cause personal injury and/or damage to the power chair and electrical system. Maintain and store your power chair in a dry and clean condition.

Positioning Belts

Your authorized Pride Provider, therapist(s), and other healthcare professionals are responsible for determining your requirement for a positioning belt in order to operate your power chair safely.



WARNING! If you require a positioning belt to safely operate your power chair, make sure it is fastened securely. Serious personal injury may result if you fall from the power chair.

WARNING! The positioning belt is not designed for use as a seat belt in a motor vehicle. Nor is your power chair suitable for use as a seat in any vehicle. Anyone traveling in a vehicle should be properly belted into seats approved by the vehicle manufacturer.

Reaching and Bending

Never reach, lean, or bend while driving your power chair. If it is absolutely necessary to reach, lean, or bend while seated on your power chair, it is important to maintain a stable center of gravity and keep the power chair from tipping. Pride recommends that the power chair user determine his/her personal limitations and practice bending and reaching in the presence of a qualified healthcare professional.



WARNING! Do not bend, lean, or reach for objects if you have to pick them up from the floor by reaching down between your knees. Movements such as these may change your center of gravity and the weight distribution of the power chair. This may cause your power chair to tip, possibly resulting in personal injury.

WARNING! Prevent personal injury! Keep your hands away from the tires when driving. Be aware that loose fitting clothing can become caught in drive tires.

II. SAFETY

Batteries

In addition to following the warnings below, be sure to comply with all other battery handling information. For more information about your power chair's batteries, see VI. "Batteries and Charging."

WARNING! Power chair batteries are heavy. See specifications table. If you are unable to lift that much weight, be sure to get help. Lifting beyond your capacity can result in personal injury.



WARNING! Battery posts, terminals, and related accessories contain lead and lead compounds. Wash hands after handling.

WARNING! Always protect the batteries from freezing and never charge a frozen battery. Charging a frozen battery may result in personal injury and/or damage to the battery.

Removable Parts



WARNING! Do not attempt to lift or move a power chair by any of its removable parts. Personal injury and/or damage to the power chair may result.

Preventing Unintended Movement



WARNING! If you anticipate being seated in a stationary position for an extended period of time, turn off the power. This will prevent unexpected motion from inadvertent joystick contact. This will also eliminate the possibility of unintended chair movement from electromagnetic (EM) sources. Failure to do so may result in personal injury.

Prescription Drugs/Physical Limitations

Users must exercise care and common sense when operating a power chair. This includes awareness of safety issues when taking prescribed or over-the-counter drugs or when the user has specific physical limitations.



WARNING! Consult your physician if you are taking prescribed or over-the-counter medication or if you have certain physical limitations. Some medications and limitations may impair your ability to operate your power chair in a safe manner.

Alcohol

The power chair user must exercise care and common sense when operating his/her power chair. This includes awareness of safety issues while under the influence of alcohol.



WARNING! Do not operate your power chair while you are under the influence of alcohol, as this may impair your ability to operate your power chair in a safe manner.

II. SAFETY

Electromagnetic and Radio Frequency Interference (EMI/RFI)



WARNING! Laboratory tests have shown that electromagnetic and radio frequency waves can have an adverse affect on the performance of electrically-powered mobility vehicles.

Electromagnetic and Radio Frequency Interference can come from sources such as cellular phones, mobile two-way radios (such as walkie-talkies), radio stations, TV stations, amateur radio (HAM) transmitters, wireless computer links, microwave signals, paging transmitters, and medium-range mobile transceivers used by emergency vehicles. In some cases, these waves can cause unintended movement or damage to the control system. Every electrically-powered mobility vehicle has an immunity (or resistance) to EMI. The higher the immunity level, the greater the protection against EMI. This product has been tested and has passed at an immunity level of 20 V/m.

WARNING! Be aware that cell phones, two-way radios, laptops, and other types of radio transmitters may cause unintended movement of your electrically-powered mobility vehicle due to EMI. Exercise caution when using any of these items while operating your mobility vehicle and avoid coming into close proximity of radio and TV stations.



WARNING! The addition of accessories or components to the electrically-powered mobility vehicle can increase the susceptibility of the vehicle to EMI. Do not modify your power chair in any way not authorized by Pride.

WARNING! The electrically-powered mobility vehicle itself can disturb the performance of other electrical devices located nearby, such as alarm systems.

NOTE: For further information on EMI/RFI, go to the Resource Center on www.pridemobility.com. If unintended motion or brake release occurs, turn the power chair off as soon as it is safe to do so. Call Pride at 800-424-8205 to report the incident.

III. YOUR POWER CHAIR

YOUR POWER CHAIR

The Jazzy 1103 Ultra has two main assemblies: the seat and the power base. See figures 5 and 6. Typically, the seat assembly includes the armrests, seatback, and seat base. The power base assembly includes two motor/brake assemblies, two drive wheels, two anti-tip wheels, two caster wheels, two batteries, and the electrical components.

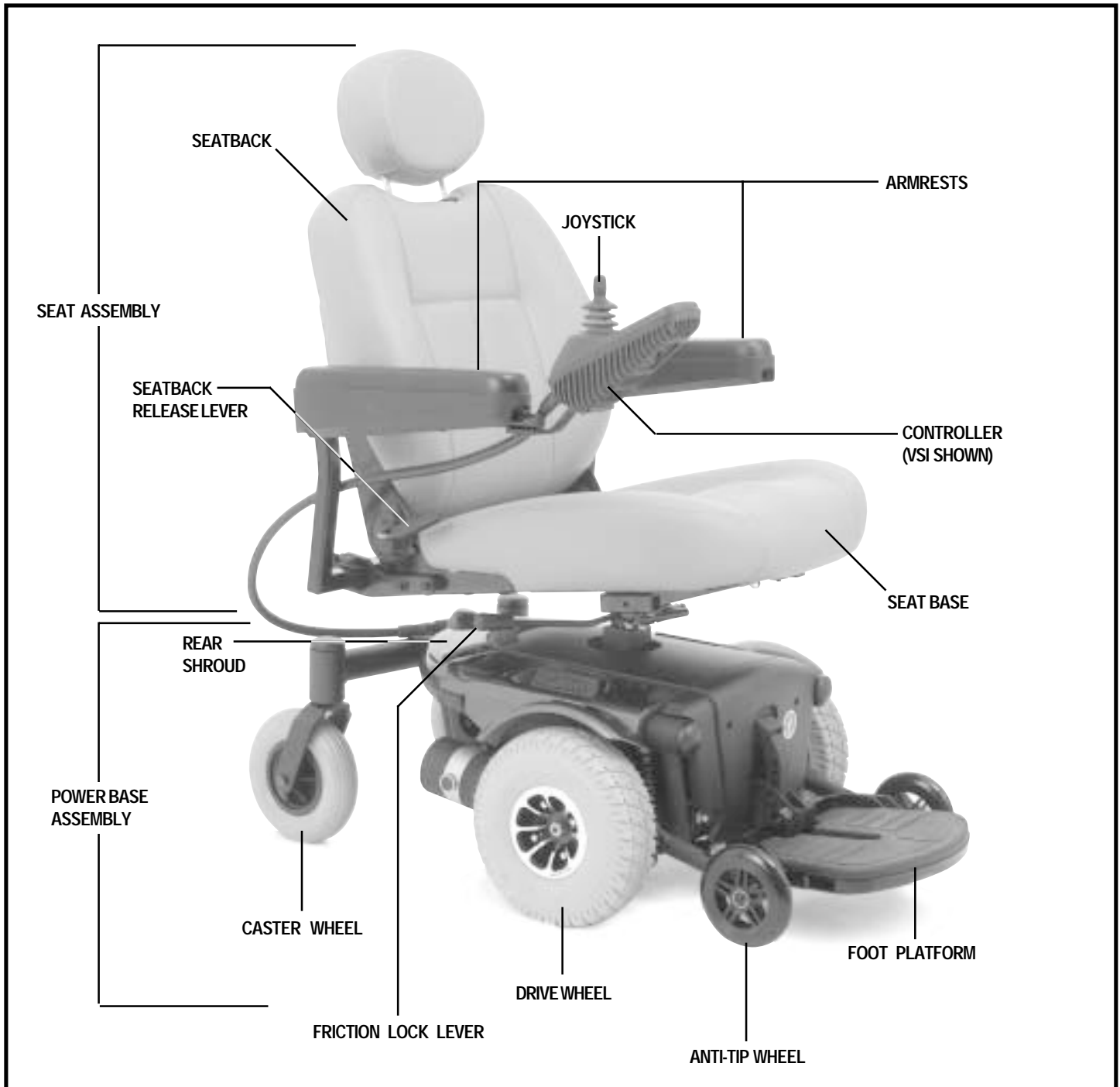

Figure 5. The Jazzy 1103 Ultra

III. YOUR POWER CHAIR

JAZZY 1103 ULTRA SPECIFICATIONS	
Suspension:	Active Trac
Drive Wheels:	10 in. pneumatic, (10 in. solid are optional)
Caster Wheels:	8 in. solid, rear-mounted
Anti-tip Wheels:	5 in. solid, front-mounted
Maximum Speed: ¹	Up to 4 mph
Brakes:	"Intelligent Braking" electronic regenerative, disc park brake
Ground Clearance: ²	2.5 in.
Turning Radius: ²	20.75 in.
Overall Size: ²	Length: 39 in. (with foot platform) Width: 23 in.
Seating Options:	Power Elevating Seat System (standard) Medium-Back Seat (optional) Limited Recline High-Back Seat (optional) Synergy Seating Systems (optional) TRU-Balance Power Positioning Systems (optional) Solid Seat Pan (optional) Speciality Seat (optional)
Drivetrain:	Two motor, mid-wheel drive
Batteries: ³	Two 12-volt, U-1 batteries
Range: ¹	Up to 25 miles
Battery Charger:	4-amp, onboard (standard) Off-board (optional)
Electronics:	50-amp PG Drives VSI Controller (standard) 70-amp PG Drives Remote Plus (optional) 70-amp PG Drives Microdrive (optional)
Weight Capacity:	300 lbs. (standard) 200 lbs. with TRU-Balance Power Positioning Systems 160 lbs. with Synergy Manual Tilt
Component Weights:	Base: 97 lbs. Medium-Back Seat: 37 lbs. (44 lbs. with Universal Friction Lock Seat Plate) Batteries: 24.5 lbs. each

¹Varies with user weight, terrain type, battery amp hour rating (AH), battery charge, battery condition, and tire condition.

²Due to manufacturing tolerances and continued product improvement, this specification can be subject to variance of (+ or -) 3%.

³AGM or Gel-Cell type recommended.

NOTE: All specifications subject to change without notice.

III. YOUR POWER CHAIR

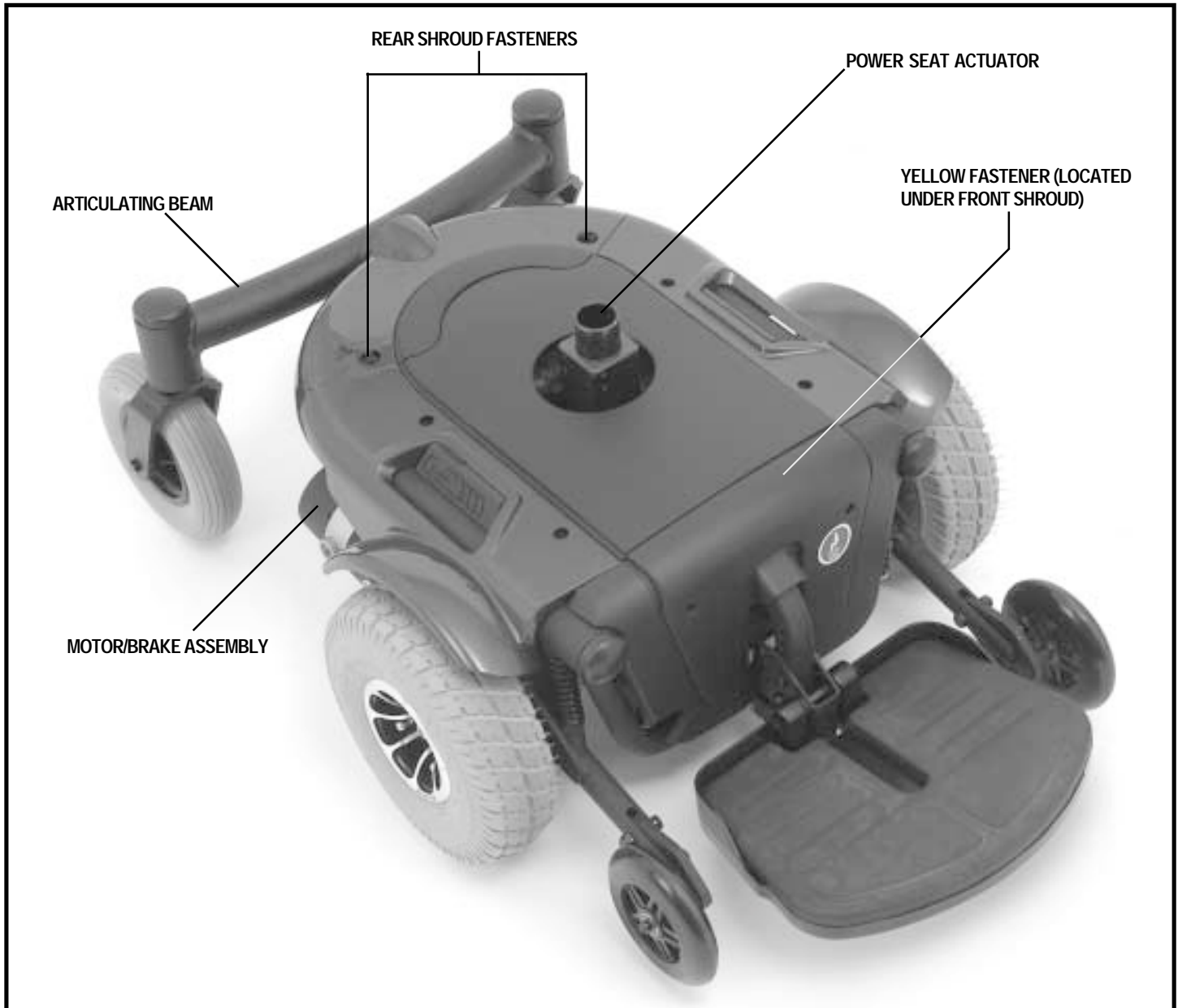

Figure 6. The Jazzy 1103 Ultra Power Base

ELECTRICAL COMPONENTS

The electrical components are located on the power base. The ammeter and the charger power cord receptacle are located on the right side of the power base. The main circuit breaker is located on the front of the battery tray. The controller connector and the motor connectors are located on the power pod, inside the power base. See figure 7.

Ammeter: The ammeter displays the charger’s current output in amps. See VI. “Batteries and Charging.”

Charger Power Cord Receptacle: This is where the charger power cord plugs into the onboard battery charger. See VI. “Batteries and Charging.”

III. YOUR POWER CHAIR

Main Circuit Breaker: The main circuit breaker is a safety feature built into your power chair. When the batteries and the motors are heavily strained (e.g., from excessive loads), the main circuit breaker trips to prevent damage to the motors and the electronics. If the circuit trips, allow your power chair to “rest” for approximately one minute. Next, push in the circuit breaker button, turn on the controller, and continue normal operation. If the main circuit breaker continues to trip repeatedly, contact your authorized Pride Provider.

Motor Connectors: This is where the controller connects to the motors. The motor connectors are color-coded with red and yellow labels. The label color on the motor connector corresponds with the label color on the power pod.

Battery Connector: This is where the controller connects to the batteries.

Power Seat Connector: This is where the power seat actuator is connected to the power pod.

Charger Inhibit Connector: The charger inhibit enables the onboard charger to disable the controller during charging. See VII. “Operation.”

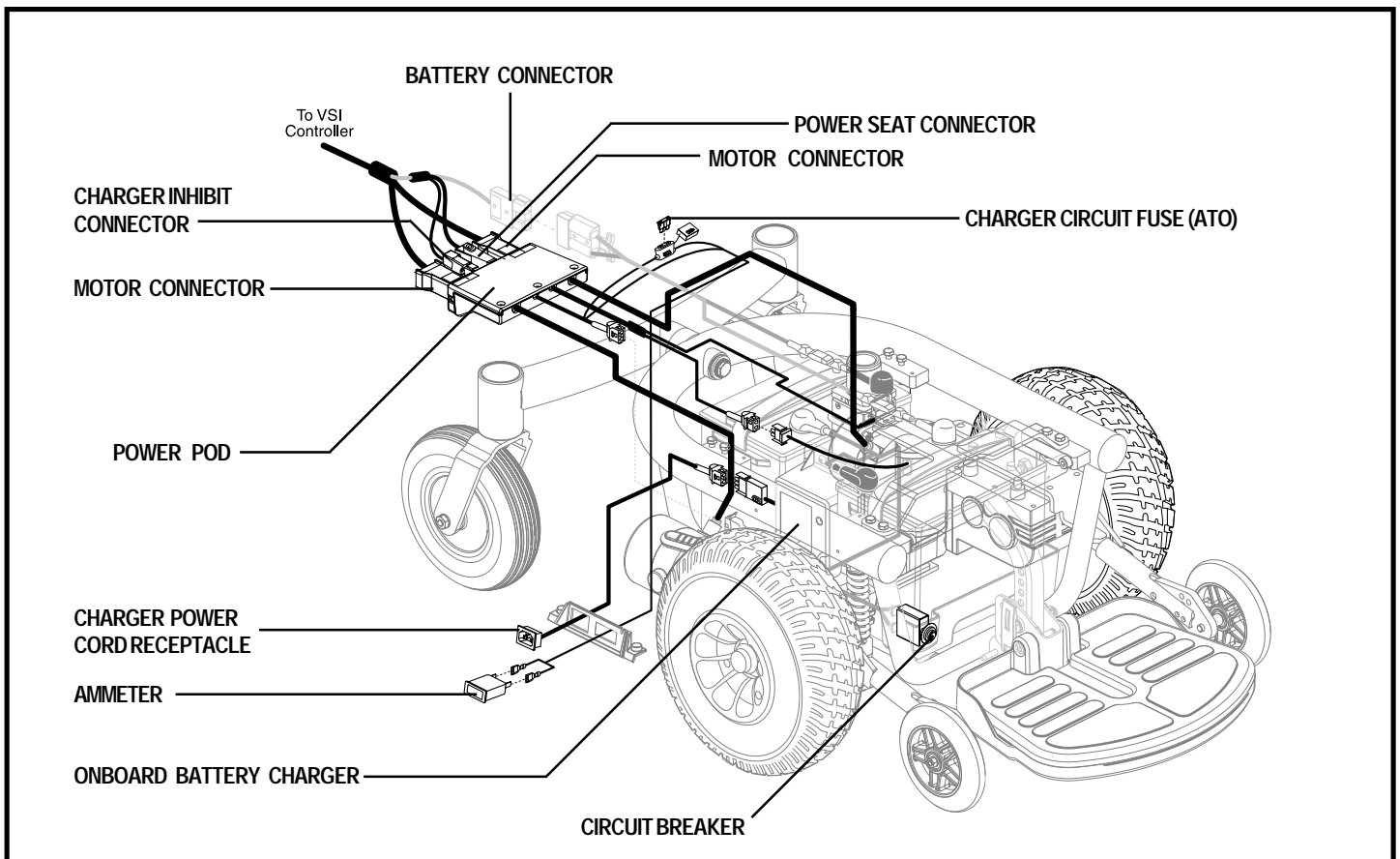

Figure 7. Jazzy 1103 Ultra Electrical Components

III. YOUR POWER CHAIR

MANUAL FREEWHEEL LEVERS

Your power chair has a manual freewheel lever on each motor. Manual freewheel levers enable you to disengage the drive motors from the gearboxes and maneuver the chair manually.



WARNING! Do not use the power chair while the drive motors are disengaged! Do not disengage the drive motors when the power chair is on an incline, as the unit could roll on its own, causing injury!

To engage or disengage the drive motors:

1. Locate the lever on top of each motor.
2. Push the two levers inward to engage the drive motors. See figure 8.
3. Pull the two levers outward to disengage the drive motors. See figure 9.

If a lever is difficult to move in either direction, slightly rock the power chair back and forth. The lever should then move to the desired position.



WARNING! It is important to remember that when your power chair is in freewheel mode, the braking system is disengaged.

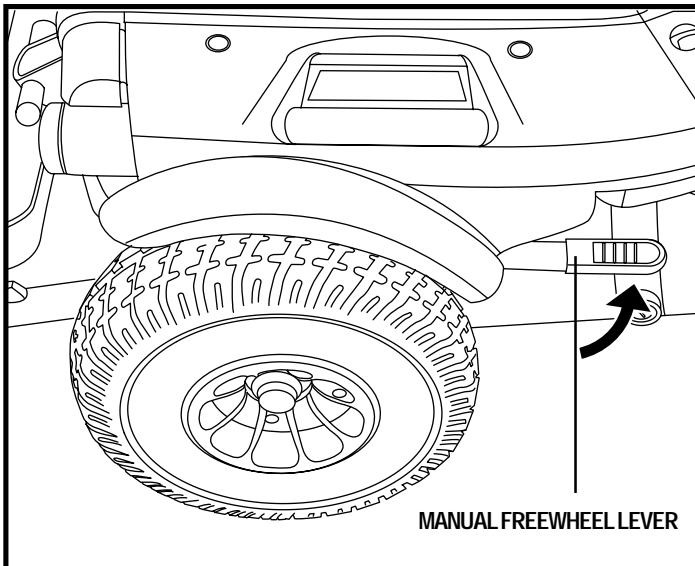

Figure 8. Drive Mode (Drive Engaged)

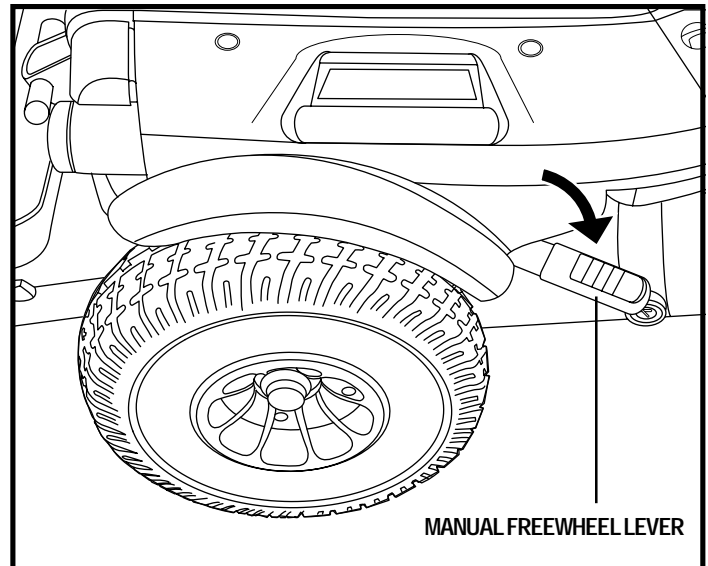

Figure 9. Freewheel Mode (Drive Disengaged)

IV. ASSEMBLY

INITIAL ASSEMBLY

Your power chair may require some assembly either before initial use or after transportation. It may also require disassembly to make some comfort adjustments. Figure 10 details those parts of the power chair that are designed to be disassembled and assembled by an end user or by a qualified caregiver before using the product or making comfort adjustments.

NOTE: Any nylon insert lock nut removed during the disassembly or adjustment of the power chair must be replaced with a new nut. Nylon insert lock nuts should not be reused as it may cause damage to the nylon insert, resulting in a less secure fit. Replacement nylon insert lock nuts are available at local hardware stores or through your authorized Pride Provider.

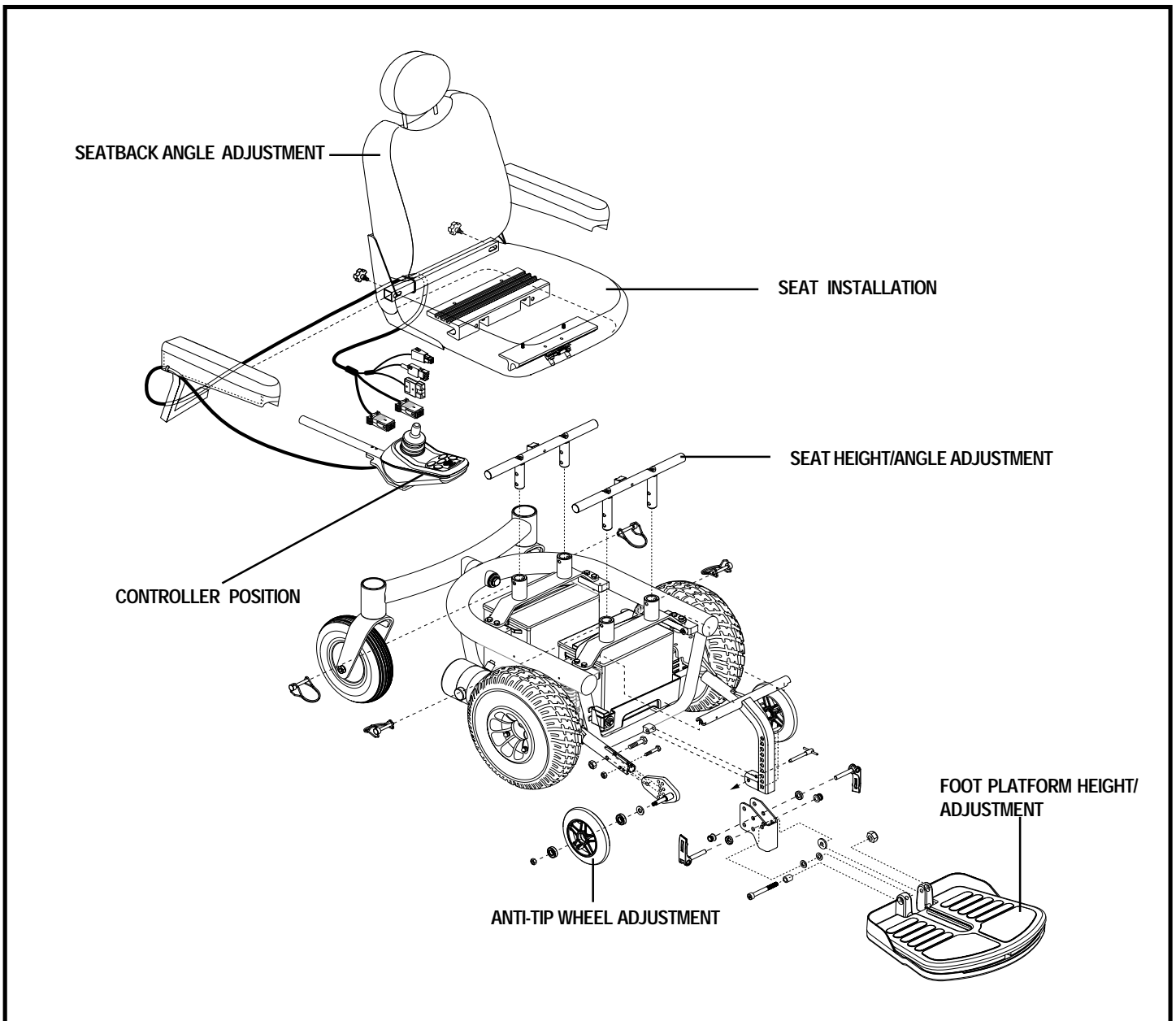

Figure 10. Jazzy 1103 Ultra Assembly View

IV. ASSEMBLY

SEAT INSTALLATION

It may be necessary to install the seat either prior to initial operation or after transporting your power chair. Most seats are attached to the power base with the Universal Mounting System (UMS). The UMS consists of universal parts that may be attached to any medium-back or high-back seat, regardless of seat width or seat depth. The two main components are aluminum extrusions mounted to the seat base. These extrusions attach to the power seat frame (see figure 11) or to a pair of trapeze bars that are mounted to the power base (see figure 12).



WARNING! Do not pick up the seat frame by the armrests. They are free to pivot, and you may lose control of the seat if they do so, resulting in personal injury or damage to the chair.

To install the seat:

1. Raise the power elevating seat actuator up 2 in. to allow for sufficient clearance.
2. Tilt the seat back and slide the rear extrusion onto the power seat frame or rear trapeze bar.
3. Lower the front extrusion onto the power seat frame or front trapeze bar until the seat locks into place.
4. Flip the seat latch safety down. See figure 11.



WARNING! Make sure the seat latch safety is flipped down before using your power chair.

5. Install the controller into one of the armrests. See V. "Comfort Adjustments."
6. Loosen the rear shroud fasteners and remove the rear shroud.
7. Route the controller connector to the back of the power base and secure the controller cable to the armrest receiver with wire ties.
8. Plug the controller connectors into the power pod and connect the battery connector. See figure 7.
9. Reinstall the rear shroud and tighten the fasteners.

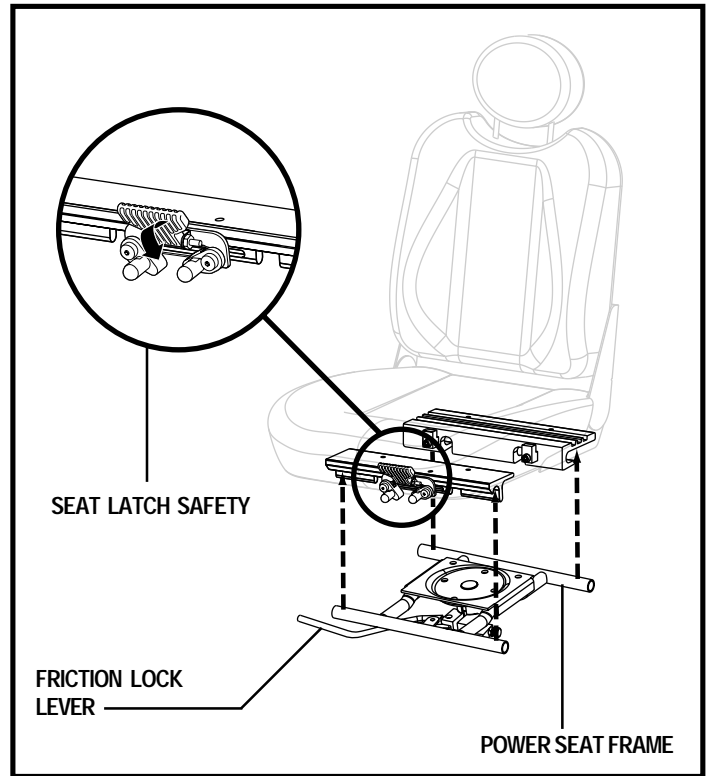

Figure 11. UMS - Power Elevating Seat System

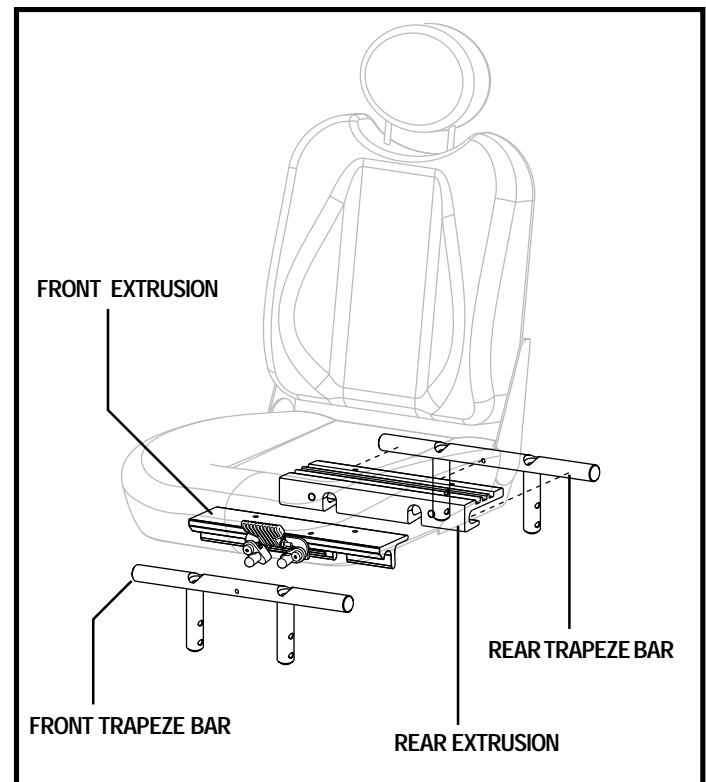

Figure 12. UMS - Optional Seating System

V. COMFORT ADJUSTMENTS

COMFORT ADJUSTMENTS

After becoming familiar with your power chair's operation, you may find the need to make some adjustments to increase your comfort, such as seat height and angle, armrest angle, foot platform height and angle, and controller position. If your power chair is equipped with a Synergy Seating or TRU-Balance Power Positioning System, refer to the information provided in separate manuals. If your power chair is equipped with a medium-back, a high-back, a reclining seat, or a power elevating seat refer to the following information.

WARNING! If your power chair was configured by your authorized Pride Provider, please consult your healthcare professional before changing the seat position or making any other adjustment. Some adjustments may degrade your power chair's performance and safety by changing its center of gravity.



WARNING! Some power chair components are heavy. You may need assistance to lift or carry them. Please refer to the specifications table for specific component weights before you disassemble the power chair.

WARNING! Prevent injury. Remove the occupant from the power chair before making any adjustments.

You may need the following to make comfort adjustments:

- metric/standard socket set and ratchet
- adjustable wrench
- thread lock

Seat Height and Seat Angle Adjustment (Optional Trapeze Bar System)

You can change the seat height to one of two positions in 1-in. increments by raising the front and rear trapeze bars. If you raise or lower only one trapeze bar (front or rear), you can also change the seat base angle (dump).

To change the seat height:

1. Turn off the power to the controller.
2. Loosen the rear shroud fasteners and remove the rear shroud. See figure 6.
3. Disconnect the controller connectors from the power pod. See figure 7.
4. Flip up the seat latch safety. See figure 13.
5. Squeeze the seat latch and release the seat from the front trapeze bar.
6. Slide the seat forward and remove it from the power base.
7. Loosen the screws that attach the trapeze bars to the seat posts. See figure 14.
8. Remove the retaining clips that secure the seat posts to the power base. See figure 14.
9. Move the trapeze bars up or down to the desired height.

NOTE: Change the seat dump by raising or lowering only one set of towers (front or back).

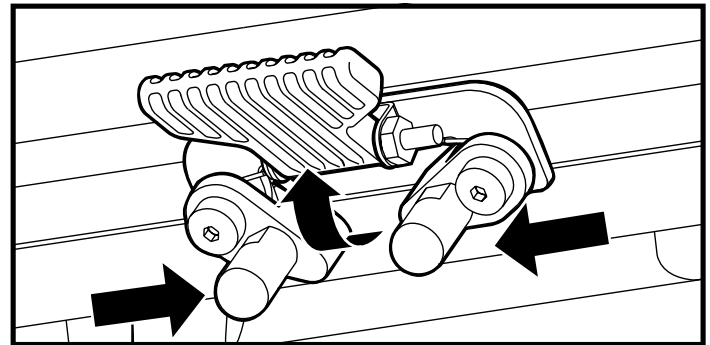

Figure 13. Seat Height Adjustment - Seat Latch Safety

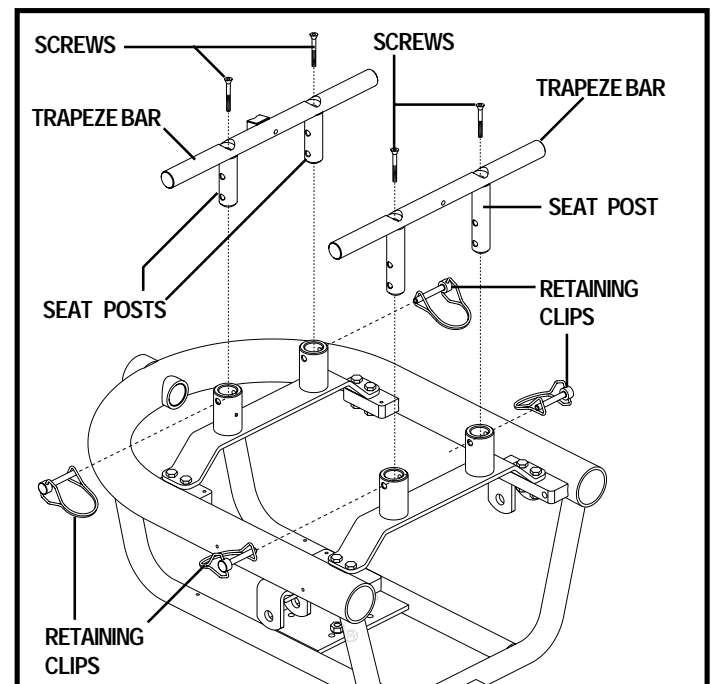

Figure 14. Trapeze Bar Location (Optional)

V. COMFORT ADJUSTMENTS

10. Reinstall the retaining clips from step 8.
11. Remove each screw from the trapeze bars and apply thread lock.
12. Reinstall each screw into the trapeze bars and tighten.
13. Reinstall the seat.
14. Reconnect the controller to the power pod.
15. Reinstall the rear shroud and tighten the fasteners.

Seat Position

You can move the seat forward or rearward by changing the extrusion mounting position.

To change the position:

1. Turn off the power to the controller.
2. Loosen the rear shroud fasteners and remove the rear shroud.
3. Unplug the controller connectors from the power pod.
4. Remove the seat from the power base.
5. Remove both extrusions from the bottom of the seat.
6. Reposition the extrusions on a different set of mounting holes. You must move both extrusions the same number of holes either forward or backward. See figure 15.
7. Fasten the extrusions back onto the bottom of the seat.
8. Reinstall the seat.
9. Plug the controller connectors into the power pod.
10. Reinstall the rear shroud and tighten the fasteners.

Seatback Angle Adjustment

If your power chair is equipped with an adjustable seatback, you can adjust it to four (4) different angles: 90°, 102°, 105°, or 107°.

To adjust the seatback angle:

1. Remove the adjusting screws from each seat hinge. See figure 16.
2. Set the seatback at the desired angle.
3. Reinstall the adjusting screws to each seat hinge and tighten.

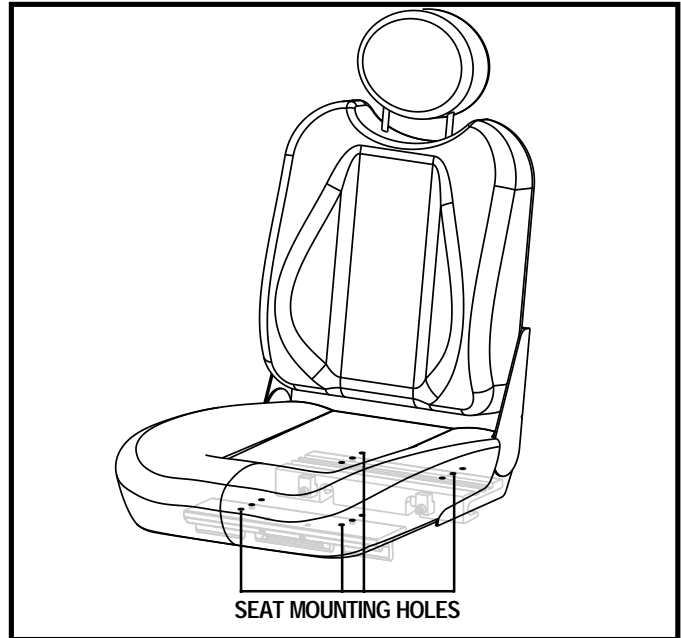

Figure 15. Seat Mounting Holes

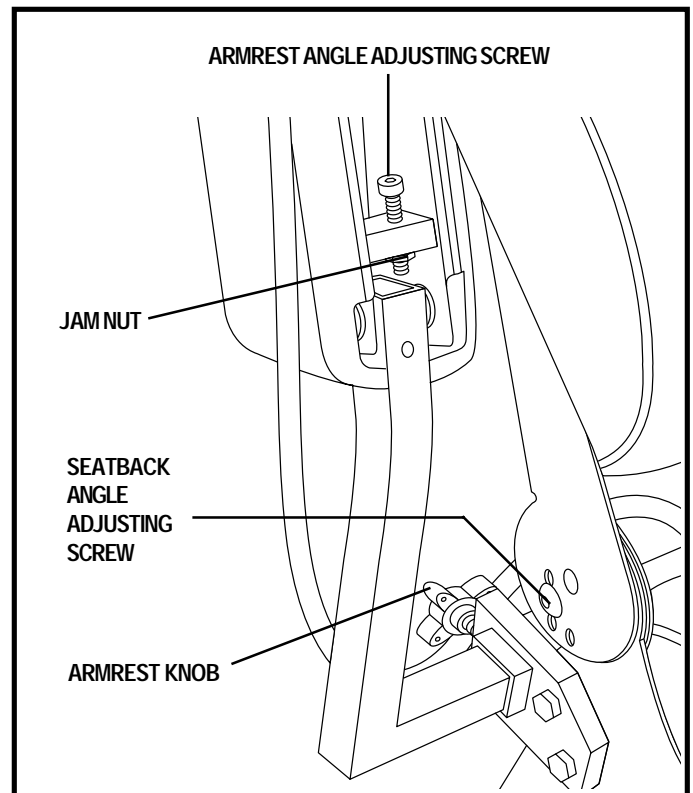

Figure 16. Seatback Angle Adjustment

V. COMFORT ADJUSTMENTS

Reclining Seat

If your power chair is equipped with a reclining seat, you can adjust the seatback angle with the seatback release lever. The lever is located on the right side of the seat base. See figure 5.

To adjust the recline angle:

1. Pull up on the seatback release lever.
2. Lean forward or backward to the desired position.
3. Release the lever.

Armrest Width Adjustment

You can change each armrest's width independently of the other.

NOTE: Changing the armrest width may increase the overall width of your power chair.

To change the armrest width:

1. Locate the two armrest knobs on each side of the armrest receiver bracket. See figure 16.
2. Loosen the knobs.
3. Slide the armrests in or out to the desired width.
4. Tighten the knobs.

Armrest Angle Adjustment

To change the armrest angle:

1. Lift the armrest straight up so that it is perpendicular to the floor. See figure 16.
2. Loosen the jam nut.
3. Turn the adjusting screw clockwise to raise the front of the armrest, or turn the adjusting screw counterclockwise to lower the front of the armrest.
4. Tighten the jam nut to lock the adjusting screw into place.

Foot Platform Height Adjustment

The foot platform height is easily adjusted to different heights in 1/2-in. increments.

To raise or lower the foot platform:

1. Remove the quick release fasteners from the foot platform bracket. See figure 17.
2. Raise or lower the foot platform to the desired height.
3. Reinstall the quick release fasteners into the foot platform bracket and tighten.

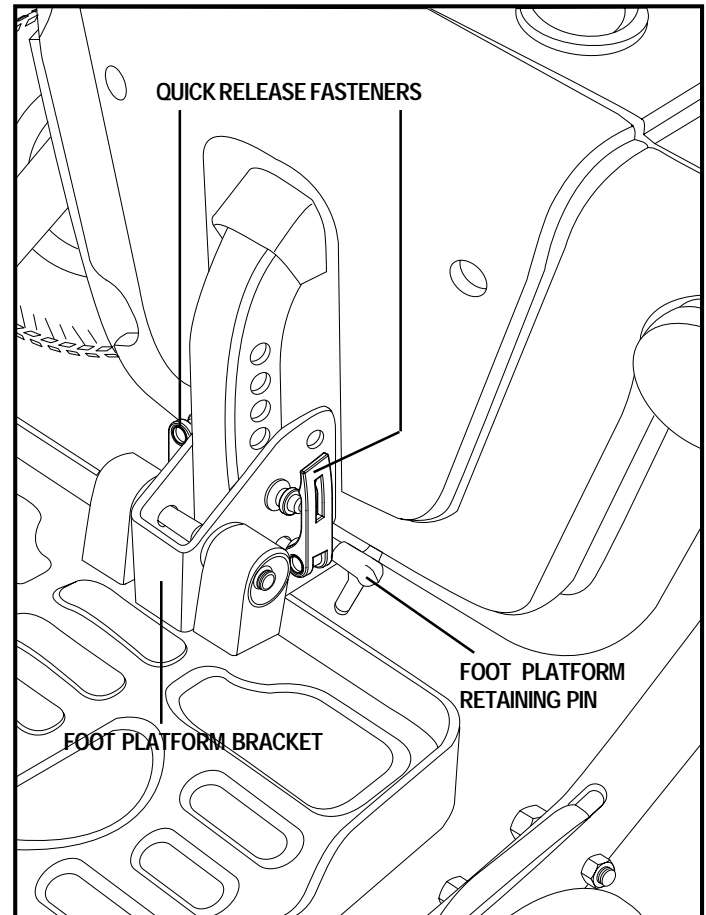

Figure 17. Foot Platform Adjustment

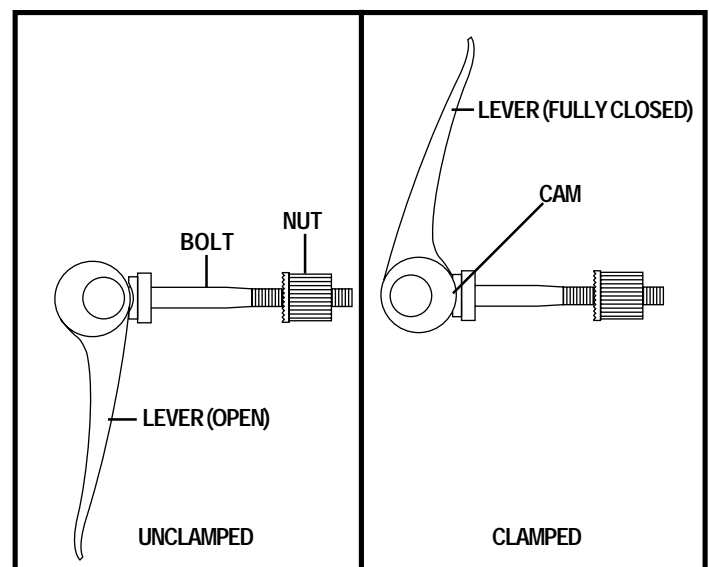

Figure 18. Quick Release Fastener Operation

Foot Platform Depth Adjustment

To adjust the foot platform depth:

1. Remove the quick release fasteners from the foot platform bracket. See figure 17.
2. Move the foot platform in or out to the desired depth.
3. Reinstall the quick release fasteners into the foot platform bracket and tighten.

Quick Release Fasteners: The foot platform is attached to the power base with two quick release fasteners. See figure 17. Each quick release fastener consists of a bolt, a lever, and a nut. See figure 18. The lever has a cam on the end that allows it to clamp into place. The quick release fastener has two states: clamped and unclamped. When the lever is open, the quick release fastener is unclamped. When the lever is closed, the quick release fastener is clamped.

To clamp the quick release fastener:

1. Make sure the lever is in the open position.
2. Turn the nut clockwise until it is snug.
3. Rotate the lever until it is in the fully closed position.

NOTE: *If the lever will not rotate to the fully closed position, then turn the nut counterclockwise one-quarter or one-half turn.*

Foot Platform Angle Adjustment

You can adjust the angle of the foot platform with a hex key. See figure 19.

To adjust the foot platform angle:

1. Flip up the foot platform and locate the setscrew.
2. Turn the setscrew counterclockwise to raise the front of the foot platform.
3. Turn the setscrew clockwise to lower the front of the foot platform.

Controller Position

You can position the controller for either left-hand or right-hand use.



WARNING! Do not place the controller cable so that it can be pinched in the seat frame or the power base frame.

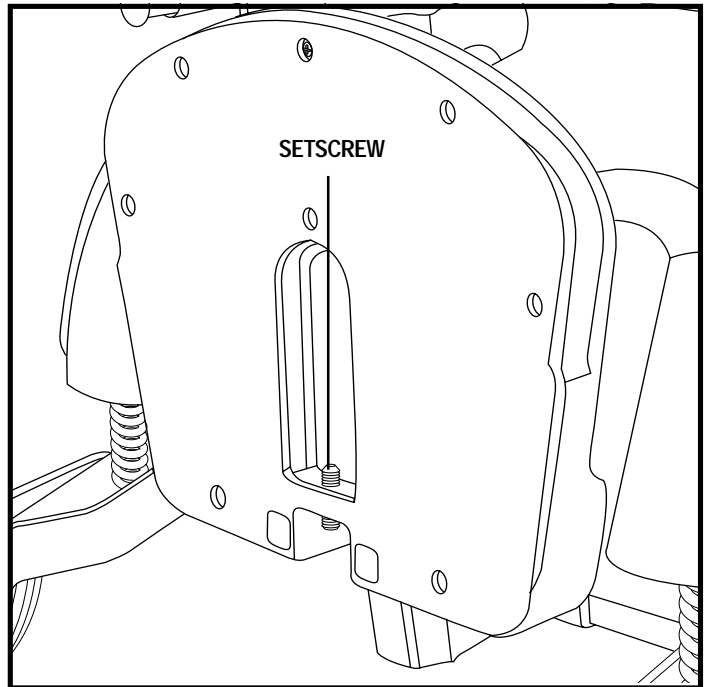

Figure 19. Bottom View of Footrest

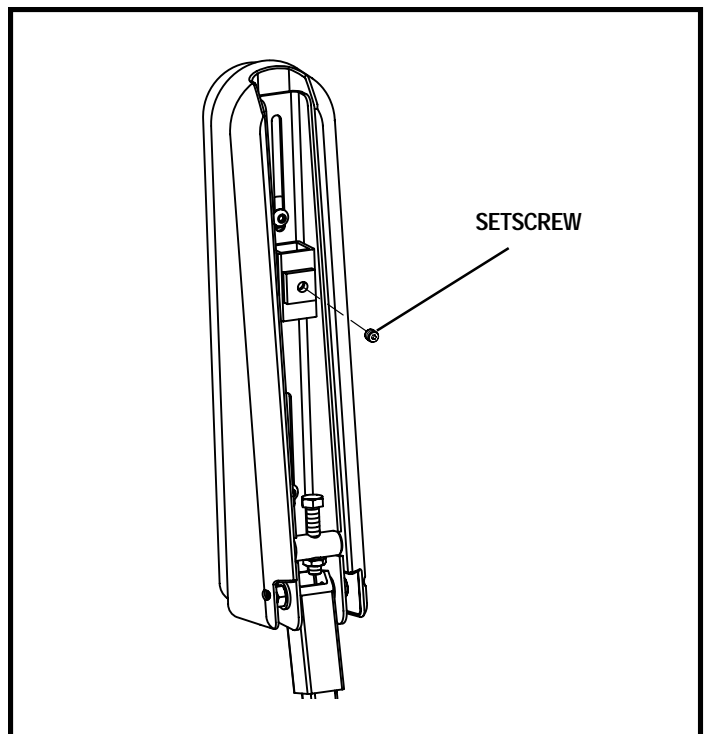

Figure 20. Underside of Armrest

V. COMFORT ADJUSTMENTS

To change the controller position:

1. Turn off the power to the controller.
2. Loosen the rear shroud fasteners and remove the rear shroud.
3. Unplug the controller connectors from the power pod.
4. Cut the wire ties that attach the controller cable to the armrest.
5. Locate the setscrew on the underside of the armrest. See figure 20.
6. Slide the controller out of the armrest.
7. Loosen the setscrew in the other armrest.
8. Place the controller in the other armrest.
9. Tighten the setscrew to secure the controller.
10. Route the controller connector to the back of the power base and secure the controller cable to the armrest receiver with wire ties.
11. Plug the controller connectors into the power pod. See figure 7.
12. Reinstall the rear shroud and tighten the fasteners.

Swing-away Footrests

Swing-away Footrests (SFRs) enable you to rotate the footrests to the side before you transfer onto or off of your power chair.

To rotate the SFRs:

1. Push in the release lever. See figure 21.
2. Rotate the SFRs.

To adjust the SFR length:

1. Remove the two adjustment screws from the side of each foot rest extension. See figure 21.
2. Slide the foot rest up or down to the desired length.
3. Reinstall the two adjustment screws.

Elevating Leg Rests

Elevating Leg Rests (ELRs) offer an infinite range of adjustment for the leg angle and a footrest adjustment range of 12–19 in.

To rotate the ELRs:

1. Push in release lever A. See figure 22.
2. Rotate the ELRs.

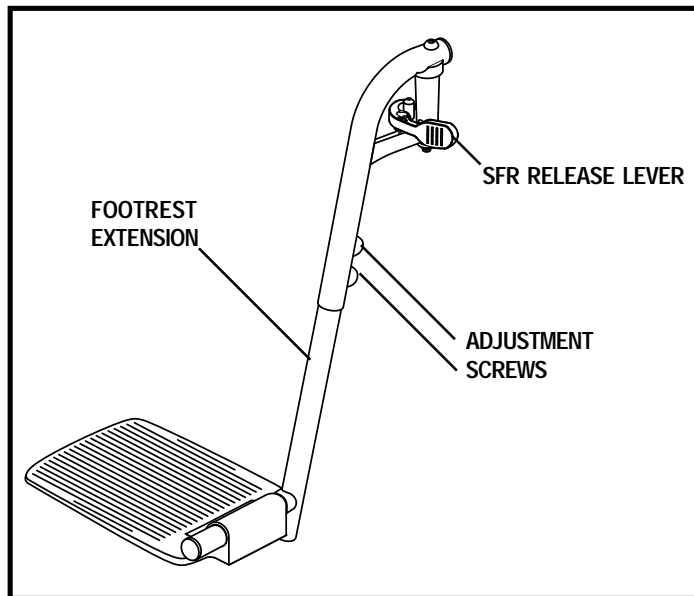

Figure 21. Swing-Away Footrests

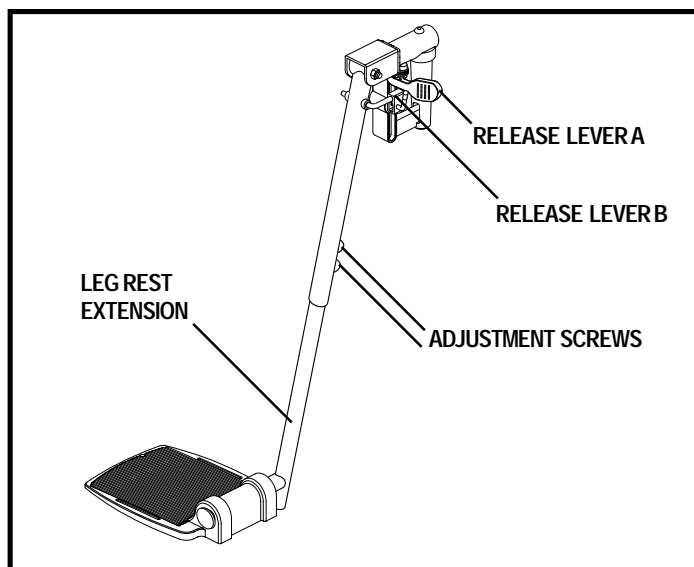

Figure 22. Elevating Leg Rests

V. COMFORT ADJUSTMENTS

To adjust the ELR angle:

1. Push down release lever B. See figure 22.
2. Move the leg rest to the desired angle.

To adjust the ELR length:

1. Remove the two adjustment screws from the side of each leg rest extension. See figure 22.
2. Slide the leg rest up or down to the desired length.
3. Reinstall the two adjustment screws.

Heavy Duty Drop-in Leg Rests

You can adjust the forward/back position, as well as the length of the heavy duty drop-in leg rests.

To adjust the forward/back position:

1. Remove the adjustment bolt from each side rail. See figure 23.
2. Move the leg rest hanger in or out to the desired position.
3. Align the adjustment holes in the leg rest hanger with those in the side rail.
4. Reinstall the adjustment bolts to secure the leg rest hangers.

To adjust the leg rest length:

1. Remove the adjustment screws from the leg rest extension.
2. Slide the leg rest up or down to the desired length.
3. Align the adjustment holes in the leg rest extension and reinstall the adjustment screws.

Anti-Tip Wheels

The anti-tip wheels are designed to give your power chair increased stability on rough surfaces. The anti-tip wheels are preset at the factory for smooth surfaces or indoor use only. If you plan on using your power chair on rough surfaces, it may be necessary to adjust the anti-tip wheels to better suit your needs. The anti-tip wheels may need adjustment if the following occurs:

- When coming to a stop, your power chair tips forward excessively.
- The anti-tip wheels constantly rub the ground.

WARNING! Consult your authorized Pride Provider before attempting to change the anti-tip wheel height! Changing the anti-tip wheel height affects handling under acceleration!



WARNING! The higher you raise the anti-tip wheels, the more you increase your power chair's tendency to tilt forward while decelerating. You can compensate for this by having your authorized Pride Provider make a small adjustment to the pre-programmed deceleration setting in the controller or by moving the seat assembly farther to the back of your power chair.



PROHIBITED! Do not remove the anti-tip wheels.

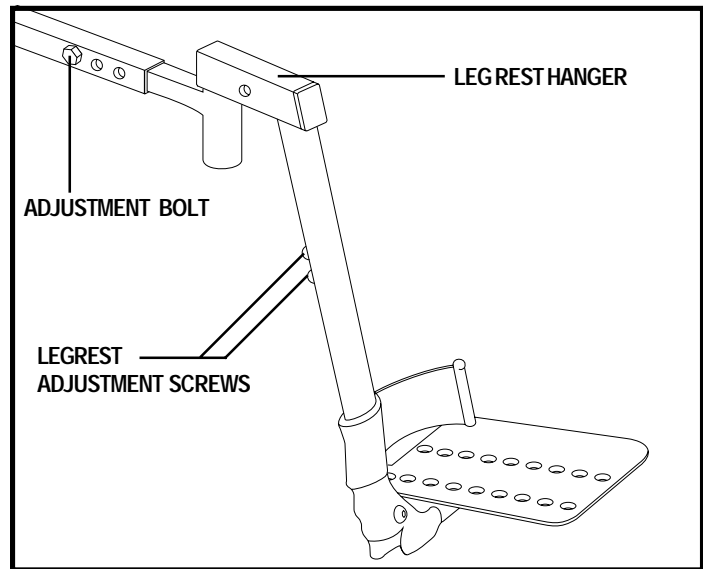

Figure 23. Heavy Duty Drop-In Leg Rests

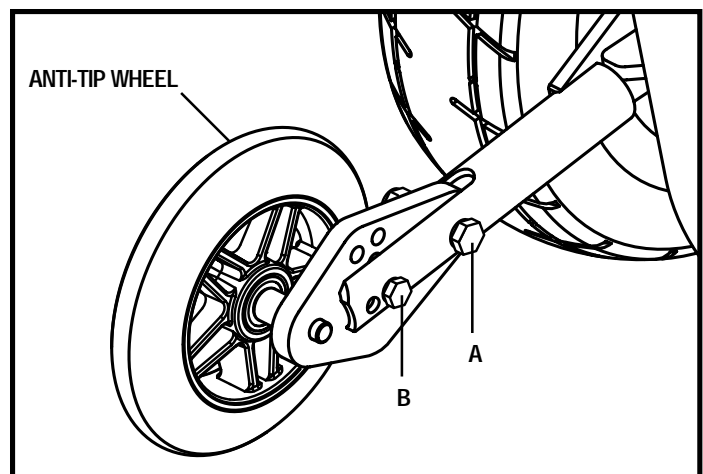

Figure 24. Anti-Tip Wheel Assembly

V. COMFORT ADJUSTMENTS

NOTE: Each drive tire (pneumatic only) must be inflated to 35 psi (2.4 bar) and the user must also be seated in the power chair in order to properly adjust the anti-tip wheels.

To adjust the anti-tip wheels:

1. Loosen bolt A. See figure 24.
2. Remove bolt B.
3. Raise or lower the anti-tip wheel bracket. Each hole is 1/2-in. apart.
4. Reinstall bolt B.
5. Tighten bolt A.
6. Raise or lower the other anti-tip wheel so that it is at the same height.

Power Elevating Seat System (Standard)

The power elevating seat system is equipped with a power elevating seat actuator that enables you to raise and lower the seat automatically. See figure 25. The power elevating seat system can enhance the capabilities of the power chair several ways:

- By raising the seat, you extend your level of reach to allow more freedom and independence in many environments.
- By raising or lowering the seat, you can easily adjust the seat height to any surface to which you want to transfer. .
- By raising the seat, you are closer to the eye level of standing persons. This provides better interaction.

For all the benefits your power elevating seat system can provide you, there are limitations. Observe the following precautions in order to ensure safe use of the power elevating seat system.

WARNING! Read and understand this owner's manual thoroughly before operating the power chair.

WARNING! Failure to heed the following warnings may cause the power chair to tip over, resulting in personal injury and/or damage to the power chair.

WARNING! Always fasten the positioning belt when operating the power elevating seat system.



WARNING! Never raise the seat from its lowest position on an inclined surface.

WARNING! Never raise the seat from its lowest position when operating your power chair on bumpy or uneven surfaces.

WARNING! Never raise the seat while your power chair is in the freewheel mode.

WARNING! Maintain recommended tire pressure in the drive wheel to maintain stability.

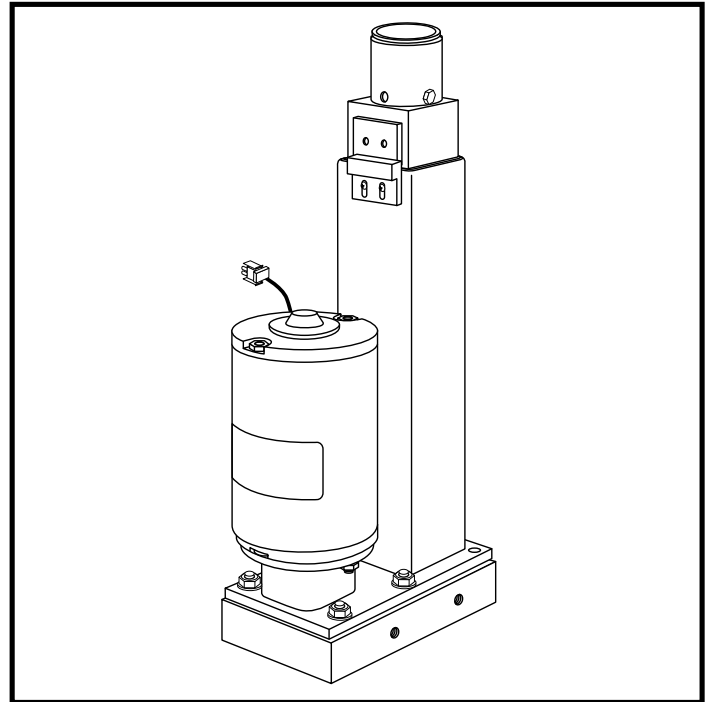

Figure 25. Power Elevating Seat Actuator

NOTE: The power elevating seat option is equipped with a system that reduces the speed of the power chair by one-half when the seat is elevated more than 1-2 inches. Always check to be sure this system is operating properly before using your power chair

V. COMFORT ADJUSTMENTS

Power Elevating Seat Operation

If your power chair is equipped with a power elevating seat, you can change the seat height either through the controller or through a toggle switch mounted to one of the armrests. See figure 26.

NOTE: For information on how to raise and lower your seat through the controller, contact your authorized Pride Provider.

To operate the power elevating seat:

1. Bring your power chair to a complete stop.
2. Push the toggle switch forward to raise the seat or pull the switch rearward to lower the seat. When you release the switch, the seat will stop.

The power elevating seat system has an upper and a lower limit of travel. Once the actuator reaches either one of these limits, you should continue to hear and/or feel the actuator motor running. This is because there is a clutch mechanism that allows the motor to continue running after the actuator has reached its limit. This clutch works at both the top and bottom extensions of the lift.



WARNING! Do not allow the motor to run more than a few seconds after the mechanism reaches the top or bottom limit. This can damage the motor.

The power elevating seat is equipped with a swivel feature that allows the seat to be turned 90 degrees to whichever side the controller is located.

To use the swivel feature:

1. Locate the friction lock lever under the seat. See figure 11.
2. Pull back the friction lock lever to rotate the seat in 90° increments.
3. Pull the friction lock lever forward to lock the seat in place.



WARNING! Prevent personal injury! Do not attempt to drive the power chair with the seat facing to the side. Always return the seat to the forward facing position before operating the power chair.

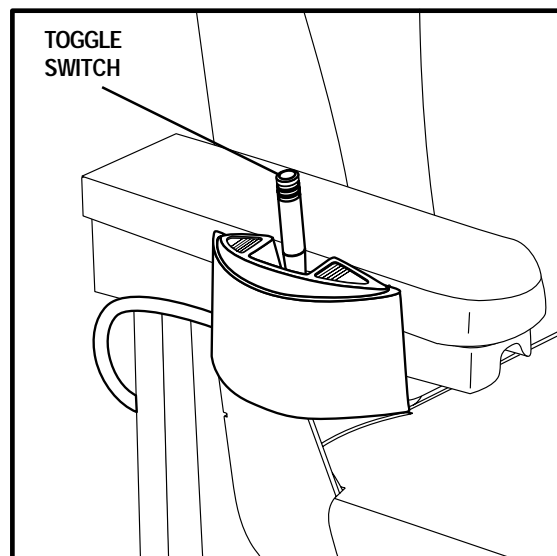

Figure 26. Power Seat Toggle Switch

VI. BATTERIES AND CHARGING

BATTERIES AND CHARGING

Your power chair uses two long-lasting, 12-volt, deep-cycle batteries. These batteries are sealed and maintenance free. Since they are sealed, there is no need to check the electrolyte (fluid) level. Deep-cycle batteries are designed to handle a longer and deeper discharge. Though they are similar in appearance to automotive batteries, they are not interchangeable. Automotive batteries are not designed to handle a long, deep discharge, and also are unsafe for use in power chairs.

WARNING! Battery posts, terminals, and related accessories contain lead and lead compounds. Wash hands after handling.



WARNING! Prevent injury and/or equipment damage! Do not use batteries that exceed the recommended type and amp-hour capacity. Do not use batteries with different amp-hour capacities. Refer to specifications table in this manual and in the manual supplied with the battery charger for recommended type and capacities.

Charging the Batteries

The battery charger is essential in providing long life for your power chair batteries. It is designed to optimize your power chair's performance by charging the batteries safely, quickly, and easily. The battery charging system consists of the onboard battery charger, the charger circuit fuse, and the ammeter. The ammeter indicates the rate of charge necessary to fully recharge the batteries. It is also a good indication of whether or not the charger is working. The ammeter and the charger are only functional when the charger power cord is plugged into an electrical outlet. The charger circuit has an ATO fuse that protects the ammeter. See figure 7.



PROHIBITED! Removal of grounding prong can create electrical hazard. If necessary, properly install an approved 3-pronged adapter to an electrical outlet having 2-pronged plug access. Failure to heed could result in personal injury and/or property damage.



PROHIBITED! Never use an extension cord to plug in your battery charger. Plug the charger directly into a properly wired standard electrical outlet.

WARNING! You must recharge your power chair's batteries with the supplied onboard charger. Do not use an automotive-type battery charger.

WARNING! Prevent injury and/or equipment damage! Read the battery charging instructions in this manual and in the manual supplied with the battery charger before charging the batteries.

WARNING! Prevent injury and/or equipment damage! Do not expose the off-board battery charger to rain or other sources of moisture unless it has been tested for outdoor use. Refer to the manual supplied with the battery charger for more information.



WARNING! Prevent injury and/or equipment damage! Explosive gases may be generated while charging the batteries. Keep the power chair and battery charger away from sources of ignition such as flames or sparks and provide adequate ventilation when charging the batteries.

WARNING! Prevent injury and/or equipment damage! Inspect the battery charger, wiring, and connectors for damage before each use. Contact your authorized Pride Provider if damage is found.

WARNING! Prevent injury and/or equipment damage! Do not attempt to open the battery charger case. If the battery charger does not appear to be working correctly, contact your authorized Pride Provider.

WARNING! Prevent injury and/or equipment damage! If the off-board battery charger is equipped with cooling slots, then do not attempt to insert objects through these slots.

WARNING! Prevent injury and/or equipment damage! Do not allow unsupervised children to play near the power chair while the batteries are charging.

VI. BATTERIES AND CHARGING



WARNING! Prevent injury and/or equipment damage! If your off-board battery charger has not been tested and approved for outdoor use, then do not expose it to adverse or extreme weather conditions. If the battery charger is exposed to adverse or extreme weather conditions, then it must be allowed to adjust to the difference in environmental conditions before use indoors. Refer to the manual supplied with the battery charger for more information.

To charge the batteries using the onboard charger:

1. Position the rear of your power chair close to a standard electrical outlet.
2. Be certain the controller power is turned off and the freewheel levers are in the engaged position. See III. “Your Power Chair.”
3. Plug the charger power cord into the charger power cord receptacle on the power base, then into the electrical outlet.

NOTE: *The power chair incorporates an inhibit function that disables the power chair when the charger is plugged into an electrical outlet.*

4. We recommend you charge the batteries for 8 to 14 hours. As the batteries charge, the ammeter needle slowly drops to 0.

NOTE: *The ammeter indicates how much charge is needed to fully charge the batteries. As the batteries charge, the ammeter needle slowly drops to 0. When the batteries are fully charged, the needle vibrates on or about the 0 mark on the ammeter.*

5. When your power chair’s batteries are fully charged, disconnect the charger power cord, wind up the cord, and store it in a safe place.

To charge the batteries using the optional off-board charger:

1. Position the front of your power chair next to a standard electrical outlet.
2. Be certain the controller power is turned off and the freewheel levers are in the engaged position. See III. “Your Power Chair.”
3. Plug the off-board charger into the off-board charger/programming socket on the controller. See VII. “Operation.”
4. Plug the off-board charger into the electrical outlet.

NOTE: *If it is a Pride off-board charger, then there are two lights in it. The red light indicates that power to the off-board charger is on. The green light indicates that the batteries are fully charged. If it is not a Pride off-board charger, then follow the instructions supplied by the manufacturer.*

5. When the batteries are fully charged, unplug the off-board charger from the electrical outlet and then from the controller.

Battery Break-in

To break in new batteries for maximum efficiency:

1. Fully recharge any new battery prior to its initial use. This brings the battery up to about 90% of its peak performance level.
2. Operate your power chair throughout the house and yard. Move slowly at first, and do not travel too far until you become accustomed to the controls and break in the batteries.
3. Give the batteries another full charge of 8 to 14 hours and operate your power chair again. The batteries will now perform at over 90% of their potential.
4. After four or five charging cycles, the batteries will top off at 100% charge and last for an extended period.

VI. BATTERIES AND CHARGING

Frequently Asked Questions (FAQs)

How does the charger work?

The battery charger takes the standard electrical outlet voltage (alternating current) and converts it to 24 VDC (direct current). The power chair batteries use direct current to run your power chair. When the battery voltage is low, the charger works harder to charge the battery. As the battery voltage approaches full charge, the charger does not work as hard to complete the charging cycle. When the battery is fully charged, the amperage from the charger is nearly at zero. This is how the charger maintains a charge but does not overcharge the battery.

Can I use a different battery charger?

You should use the charger supplied with the power chair. It is the safest, most efficient tool to charge the batteries. We do not recommend using other types of chargers (e.g., an automotive battery charger).

NOTE: *Your power chair's charger will not operate after the batteries have been discharged to nearly zero voltage. If this happens, call your authorized Pride Provider for assistance.*

How often must I charge the batteries?

Many factors come into play when deciding how often to charge the batteries. You may use your power chair all day on a daily basis or you may not use it for weeks at a time.

■ Daily Use

If you use your power chair on a daily basis, charge the batteries as soon as you are finished using your power chair. Your power chair will be ready each morning to give you a full day's service. It is recommended that you charge the batteries 8 to 14 hours after daily use.

■ Infrequent Use

If you use your power chair infrequently (once a week or less), you should charge the batteries at least once per week for 12 to 14 hours.

NOTE: *Keep your batteries fully charged and avoid deeply discharging your batteries. Do not charge the batteries for more than 24 hours at a charging cycle.*

How can I get maximum range or distance per charge?

Rarely do you have an ideal driving situation such as smooth, flat, hard terrain with no wind, hills, or curves. More often you are presented with hills, sidewalk cracks, uneven and loosely packed surfaces, curves, and wind. All of these factors will affect the distance or running time per battery charge. Below are a few suggestions for obtaining the maximum range per charge:

- Always charge the batteries fully prior to your trip.
- Plan your trip in advance to avoid inclines if possible.
- Limit baggage weight to essential items.
- Try to maintain an even speed and avoid stop-and-go driving.

What type of batteries should I use?

We recommend deep-cycle batteries that are sealed and maintenance free. Both AGM and Gel-Cell are deep-cycle batteries that are similar in performance.



WARNING! Corrosive chemicals contained in batteries. Use only AGM or Gel-Cell batteries to reduce the risk of leakage or explosive conditions.

VI. BATTERIES AND CHARGING

Why do my new batteries seem weak?

Deep-cycle batteries employ a much different chemical technology than that used in car batteries, nickel-cadmium (nicads), or in other common battery types. Deep-cycle batteries are specifically designed to provide power, drain down their charge, and then accept a relatively quick recharge. AGM and Gel-Cell batteries should be charged as often as possible. They do not have a “memory” like nickel-cadmium batteries.

We work closely with our battery manufacturer to provide a battery that best suits your power chair’s specific demands. Fresh batteries arrive regularly at Pride and are promptly shipped with a full charge. During shipping, the batteries encounter temperature extremes that may influence initial performance. Heat robs the charge from the battery, and cold slows the power available and extends the time needed to recharge the battery (just as with a car battery).

It might take a few days for the temperature of the battery to stabilize and adjust to its new ambient temperature. More importantly, it will take a few “charging cycles” (a partial drain— then a full recharge) to establish the critical chemical balance that is essential to the battery’s peak performance and long life. It will be well worth it to take the time to break in your battery properly.

How can I ensure maximum battery life?

A fully charged deep-cycle battery will provide reliable performance and extended battery life. Keep your power chair’s batteries fully charged whenever possible. Batteries that are regularly and deeply discharged, infrequently charged, or stored without a full charge may be permanently damaged, causing unreliable power chair operation and limited battery life.

***NOTE:** The useful life of a battery is quite often a reflection of the care it receives.*

How should I store my power chair and its batteries?

If you do not use your power chair regularly, we recommend maintaining battery vitality by charging the batteries at least once per week.

If you do not plan on using your power chair for an extended period, fully charge the batteries prior to storage. Disconnect the battery harnesses and store the power chair in a warm, dry environment. Avoid temperature extremes, such as freezing and excessively hot conditions, and never attempt to charge a frozen battery. A cold or frozen battery should be warmed for several days prior to recharging.

What about public transportation?

AGM and Gel-Cell batteries are designed for application in power chairs and other mobility vehicles. These batteries are Federal Aviation Administration (FAA) approved, allowing safe transportation on aircraft, buses, and trains, as there is no danger of spillage or leakage. We suggest you contact the carrier’s ticket counter in advance to determine that carrier’s specific requirements.

What about shipping?

If you wish to use a freight company to ship your power chair to your final destination, repack your power chair in the original shipping container and ship the batteries in separate boxes.

VII. OPERATION

VSI ELECTRONIC CONTROLLER

The electronic controller is what you use to operate your power chair. The electronic controller enables you to move the power chair, as well as monitor battery charge, electronic controller functions, and the condition of your electrical system. The VSI electronic controller is an integral electronic controller. All of the electronics necessary to operate the power chair are contained in one module. See figure 27. Typically, the VSI is mounted to one of the armrests and is connected to the motors, batteries, and the onboard charger at the power base. The VSI may be used to control some optional systems such as power elevating seats and lights.

The controller supplied with your power chair has been pre-programmed to meet the needs of the end user. The program is set using either a personal computer with software provided by the controller manufacturer or with a hand-held programmer, also provided by the controller manufacturer.



WARNING! The controller program can affect speed, acceleration, deceleration, and braking. If it is programmed incorrectly or outside of the safe limits as determined by your healthcare professional, it can create a dangerous situation. Only the power chair manufacturer, an authorized representative of the manufacturer, or a trained service technician should program the controller.

The VSI consists of:

1. joystick
2. keypad
3. off-board charger/programming socket
4. power elevating seat actuator connector
5. charger inhibit connector
6. battery connector
7. motor connector
8. motor connector

Joystick

The joystick controls the direction and speed of your power chair. When you move the joystick from the neutral (center) position, the electromagnetic brakes release and allow your power chair to move. The farther you push the joystick from its neutral position, the faster your power chair moves. When you release the joystick and allow it to return to the neutral position, you engage the electromagnetic brakes. This causes your power chair to decelerate and come to a complete stop.



WARNING! If your power chair begins to move in an unexpected manner, immediately release the joystick. Unless the joystick is damaged, this action should stop your power chair.

Keypad

The keypad is located in front of the joystick. It contains keys necessary to operate your power chair. See figure 28.

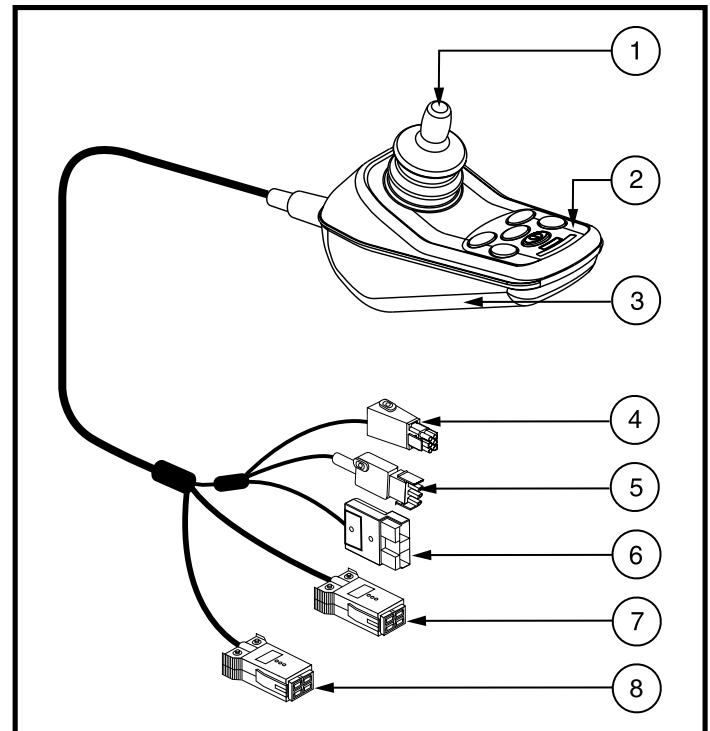

Figure 27. VSI Controller

VII. OPERATION

On/Off Key

The on/off key turns the VSI on and off.



WARNING! Unless faced with an emergency situation, do not use the on/off key to stop the power chair. This will cause the power chair to stop abruptly.

WARNING! Always turn the power off when you are stationary to prevent unexpected movement.

Battery Condition Meter

The battery condition meter is a 10-segment illuminated display located in front of the joystick. It consists of red, yellow, and green lights. When the lights are on, it indicates that there is power to the VSI. The lights also indicate battery status, VSI operational status, and electrical system status.

- **Red, yellow, and green lights lit:** Battery charged; VSI operational, and electrical system OK.
- **Red and yellow lights lit:** Charge battery if possible; VSI operational, and electrical system OK.
- **Red lights only lit or slow flash:** Charge battery as soon as possible; VSI operational, and electrical system OK.

NOTE: When the batteries approach a discharged state, the first red light will begin to slowly flash, reminding you the batteries need to be charged immediately!

- **Rapid flash of lights:** Indicates a fault in the VSI or the electrical system. Refer to “VSI Error Codes.”
- **Ripple side to side of lights:** The joystick was not in the neutral position when the controller was turned on. If you get “ripple side to side of lights,” turn off the controller, allow the joystick to return to the neutral position, then turn on the controller.

NOTE: If you still get “ripple side to side of lights,” contact your authorized Pride Provider.

Speed/Profile Keys

The speed/profile keys control either the speed setting or the drive profile. Press the speed/profile increase key to increase the speed setting or change the drive profile to a higher number. Press the speed/profile decrease key to decrease the speed setting or change the drive profile to a lower number. The speed setting or drive profile is displayed on the maximum speed/profile indicator. If your power chair was programmed with a drive profile, contact your authorized Pride Provider for more information.

NOTE: We recommend that the first few times you operate your power chair, you use the lowest speed setting until you become familiar with your new power chair.

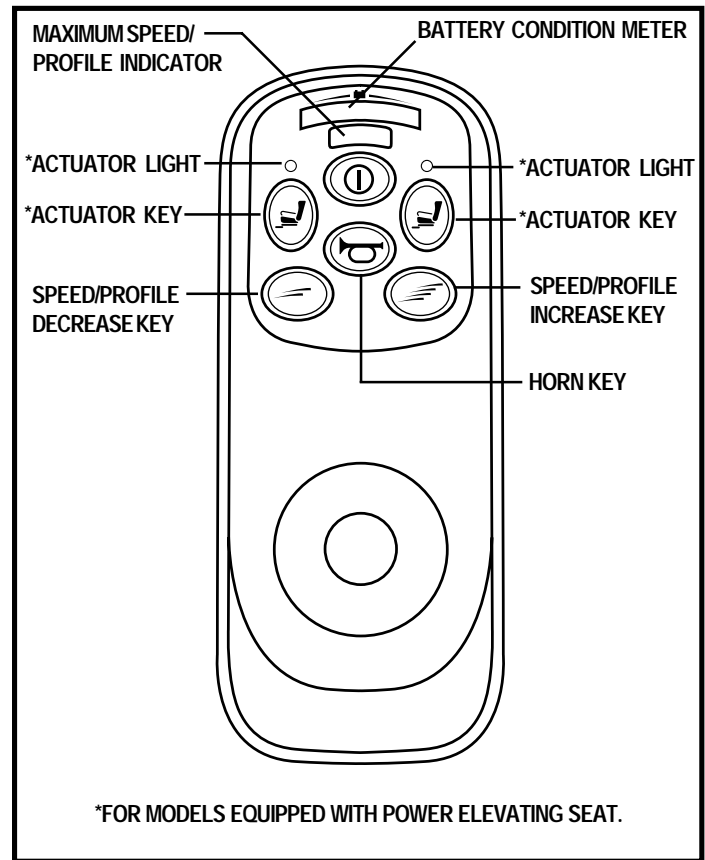

Figure 28. VSI Controller Keypad

VII. OPERATION

Actuator Keys and Actuator Lights

Actuator keys and actuator lights are used for optional equipment such as power elevating seats or power elevating leg rests. For specific operation of the actuator keys and actuator lights, contact your authorized Pride Provider.

Horn Key

The horn key activates the horn.

Locking/Unlocking the VSI

The VSI has a feature that enables you to *lock* your power chair to prevent unauthorized use.

To lock the VSI:

1. With the VSI switched on, press and hold the on/off key. After 1 second, the VSI should beep.
2. Release the on/off key.
3. Push the joystick to the full forward position until the VSI beeps.
4. Pull the joystick to the full rearward position until the VSI beeps.
5. Release the joystick. There should be a long beep.
6. The VSI is now locked.

To unlock the VSI:

1. Press the on/off key and power on the VSI. The maximum speed/profile indicator should ripple side to side.
2. Push the joystick to the full forward position until the VSI beeps.
3. Pull the joystick to the full rearward position until the VSI beeps.
4. Release the joystick. There should be a long beep.
5. The VSI is now unlocked.

NOTE: *If the above procedure fails to either lock or unlock the VSI, contact your authorized Pride Provider.*

Off-board Charger/Programming Socket

The off-board charger/programming socket is located on the front of the VSI. If you use an off-board charger, the charger current should not exceed 8 amps. Contact your authorized Pride Provider for more information.



WARNING! Only chargers with Neutrik NC3MX plugs should be connected to the off-board charger/programming socket. See your authorized Pride Provider for more information.

NOTE: *The socket may also be used for reprogramming the VSI. Contact your authorized Pride Provider for more information.*

Motor Connectors

This connects the VSI to the power chair's motors and motor brakes.

Battery Connector

This connects the VSI to the power chair's batteries.

VII. OPERATION

Power Seat Actuator Connector

This connects the VSI to the power seat actuator.

Charger Inhibit Connector

The charger inhibit connector connects the VSI to the onboard battery charger. This connection provides an inhibit that disables the VSI when the battery charger is on. The charger inhibit connector is coded with colored dots. The dots are positioned so that you align the flat side of the male connector with the flat side of the female connector before making the connection.



WARNING! Failure to properly align the connectors can result in damage to the VSI, the charger, and the connectors.

Thermal Rollback

The VSI controller is equipped with a thermal rollback circuit. This circuit monitors the temperature of the controller, which roughly translates to motor temperature. In the event that the VSI controller becomes excessively hot (above 140° F), motor current (amperage) is reduced. For every degree above 140° F, the motor current limit is reduced by .55 amps until the VSI controller reaches 158° F, at which time the current output is reduced to zero. This reduces your power chair's "power," which could also reduce your power chair's speed, and allows the electrical components and motors to cool down. When the temperature returns to a safe level, your power chair resumes its normal operation.

VSI Error Codes

The VSI controller is designed with the user's safety as the prime consideration. It incorporates many sophisticated self-test features which search for potential problems at a rate of 100 times per second. If the VSI detects a problem either in its own circuits or in the power chair's electrical system, it may decide to stop the power chair, depending on the severity of the problem. The VSI is designed to maximize the user's safety under all normal conditions. The table below identifies the individual error codes. Error codes are displayed as a rapid flashing of the battery condition meter lights. If you get one of these error codes, contact your authorized Pride Provider.

FLASHING LIGHTS	DIAGNOSIS AND SOLUTION
1	The batteries need charging or there is a bad connection to the batteries. Check the connections to the batteries. If the connections are good, try charging the batteries.
2	The left motor has a bad connection. Check the left motor connection.
3	The left motor has a short circuit to a battery connection. Contact your authorized Pride Provider.
4	The right motor has a bad connection. Check the right motor connection.
5	The right motor has a short circuit to a battery connection. Contact your authorized Pride Provider.
6	The power chair is being inhibited by the battery charger. Unplug the battery charger.
7	A joystick fault is indicated. Make sure that the joystick is in the neutral (center) position before turning on the controller.
8	A controller system fault is indicated. Make sure that all connections are secure.
9	The parking brakes have a bad connection. Check the parking brake and motor connections. Make sure the controller connections are secure.
10	An excessive voltage has been applied to the controller. This is usually caused by a poor battery connection. Check the battery connections.

VII. OPERATION

REMOTE PLUS CONTROLLER

The electronic controller is what you use to operate your power chair. The electronic controller enables you to move the power chair, as well as monitor battery charge, electronic controller functions, and the condition of your electrical system. The Remote Plus is part of a modular electronic controller system. The system consists of more than one module. Typically, the Remote Plus is mounted to one of the armrests. See figure 29. It is connected to a power module located on the power base through the controller communications cable. The Remote Plus may be used to control some optional systems, such as power elevating seats or lights through an actuator/lighting module (ALM) located on the power base.

The controller supplied with your power chair has been pre-programmed to meet the needs of the end user. The program is set using either a personal computer with software provided by the controller manufacturer or with a hand-held programmer, also provided by the controller manufacturer.



WARNING! The controller program can affect speed, acceleration, deceleration, and braking. If it is programmed incorrectly or outside of the safe limits as determined by your healthcare professional, it can create a dangerous situation. Only the power chair manufacturer, an authorized representative of the manufacturer, or a trained service technician should program the controller.

Remote Plus

The Remote Plus consists of the following:

1. joystick
2. keypad
3. controller communications cable
4. off-board charger/programming socket

Joystick

The joystick controls the direction and speed of your power chair. When you move the joystick from the neutral (center) position, the electromagnetic brakes release and allow your power chair to move. The farther you push the joystick from its neutral position, the faster your power chair moves. When you release the joystick and allow it to return to the neutral position, you engage the electromagnetic brakes. This causes your power chair to decelerate and come to a complete stop.

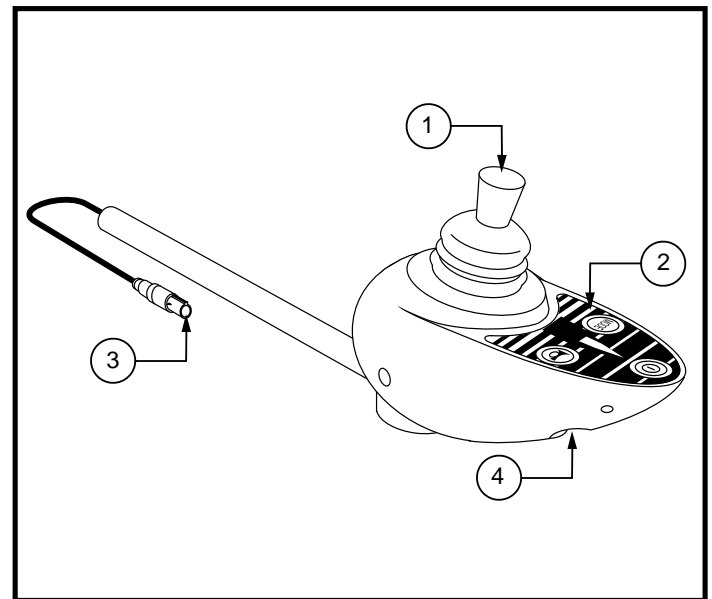

Figure 29. Remote Plus Controller



WARNING! If your power chair begins to move in an unexpected manner, immediately release the joystick. Unless the joystick is damaged, this action should stop your power chair.

Keypad

The keypad is located directly in front of the joystick. It contains keys that you will use to control your power chair. See figure 30.

On/Off Key

The on/off key turns the system on and off.



WARNING! Unless faced with an emergency situation, do not use the on/off key to stop the chair. This will cause the power chair to stop abruptly.

WARNING! Always turn the power off when you are stationary to prevent unexpected movement.

VII. OPERATION

Mode Key (Speed Settings)

The mode key controls the speed settings. The Remote Plus speed settings range from 1 to 5. Typically, the slowest speed setting is 1 and the fastest speed setting is 5. The settings are indicated by the number of lights that are lit on the speed setting indicator.

NOTE: *The speed settings are preset at the factory. If your authorized Pride Provider changes the order of these settings, please make note of these changes. Contact your authorized Pride Provider for more information.*

To select a speed setting:

1. Press the on/off key to power on the controller.
2. Press the mode key once.
3. To increase chair speed, push the joystick to the right. Each time you push the joystick, you will increase the speed setting in the speed setting indicator.
4. To decrease chair speed, push the joystick to the left. Each time you push the joystick, you decrease the speed setting in the speed setting indicator.
5. Once you select the desired speed setting, press the mode key once to keep the setting or push the joystick in the forward or reverse direction. The chair will resume operation at the selected speed.

NOTE: *We recommend that the first few times you operate your power chair, you have your speed on the slowest setting until you become familiar with your new power chair.*

Horn Key

The horn key activates the horn.

Battery Condition Meter

The battery condition meter is a 10-segment illuminated display located in front of the joystick. When the lights are on, it indicates that there is power to the Remote Plus. The lights also indicate battery status, Remote Plus operational status, and electrical system status.

- **Red, yellow, and green lights lit:** Batteries charged; controller and electrical system OK.
- **Red and yellow lights lit:** Charge batteries if possible; controller and electrical system OK.
- **Red lights only lit or slow flash:** Charge batteries as soon as possible; controller and electrical system OK.
- **Rapid flash of lights:** Indicates an error in the controller or the electrical system. See “Remote Plus Error Codes.”
- **Ripple up and down of lights:** The joystick was not in the neutral position when the controller was turned on. If you get “ripple up and down of lights,” turn off the controller and allow the joystick to return to the neutral position. Then turn on the controller.

NOTE: *If you still get “ripple up and down of lights,” contact your authorized Pride Provider.*

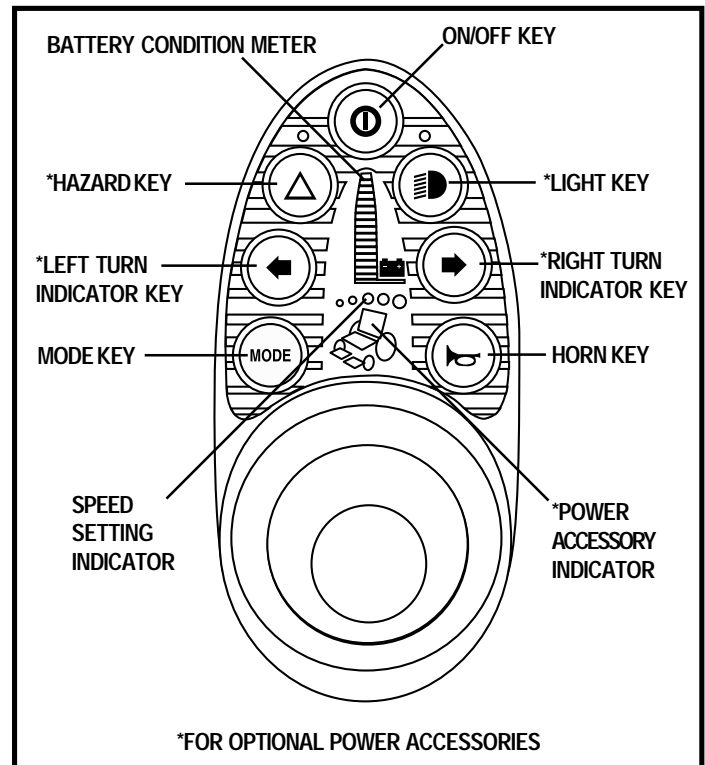

Figure 30. Remote Plus Keypad

VII. OPERATION

NOTE: *When the batteries approach a discharged state, the first red light will begin to slowly flash, reminding you the batteries need to be charged immediately!*

Right/Left Turn Indicator Keys (Optional)

The right/left turn indicator keys toggle either the left or right turn indicators. Press once to turn on and press again to turn off. You can also turn off the selected turn indicator by pressing the opposite indicator key or the hazard key.

Light Key (Optional)

The light key turns the headlights/taillights on and off independent of other indicators.

Hazard Key (Optional)

The hazard key activates both turn indicators at the same time. You can only cancel this by pressing the hazard key again.

Power Accessory Indicator (Optional)

Indicates the selected power accessory. This is for optional accessories only.

Power Accessories (Optional)

If your power chair is equipped with power accessories such as a power seat or power elevating leg rests, you can operate them through the keypad. Contact your authorized Pride Provider for information on how to operate these accessories.

Off-board Charger/Programming Socket

The off-board charger/programming socket is located on the front of the Remote Plus. If you use an off-board charger, the charger current should not exceed 8 amps. Contact your authorized Pride Provider for more information.



WARNING! Only chargers with Neutrik NC3MX plugs should be connected to the off-board charger/programming socket. See your authorized Pride Provider for more information.

NOTE: *Changes to the programming can only be made by an authorized Pride Provider.*

Controller Communications Cable

The controller communications cable provides the Remote Plus with a connection to the power module.

Sleep Mode

Your Remote Plus controller has a sleep mode feature. Sleep mode is a built-in circuit that automatically shuts off the main power if the joystick is not moved in any direction for approximately five minutes. The battery condition meter lights on the keypad indicate sleep mode by blinking once every five seconds. To restore power and continue, push the on/off key twice.

Thermal Rollback

The Remote Plus is equipped with a thermal rollback circuit. This circuit monitors the temperature of the motors, power module, and remote. In the event that any of them become excessively hot (above 122° F), motor voltage is reduced. For every degree above 122° F, the voltage is reduced by 5 volts. This reduces your power chair's speed and allows the electrical components to cool down. When the temperature returns to a safe level, your power chair resumes its normal speed.

VII. OPERATION

Remote Plus Error Codes

In addition to indicating the current state of battery charge, the battery condition meter can also indicate possible problems with your power chair's electrical system. If any of the battery condition meter lights are flashing rapidly, the controller may be indicating an error. Error codes are displayed as a number of flashing lights. For instance, if the first light is flashing rapidly, the battery voltage is nearly depleted. The table below identifies the individual error codes, probable causes, and possible solutions. If you get one of these error codes, contact your authorized Pride Provider.

FLASHING LIGHTS	DIAGNOSIS	SOLUTION
10	High Battery Voltage	Check batteries.
9	Solenoid Brake Fault	Check motor/brake wiring.
8	Possible Controller Fault	See authorized Pride Provider.
7	Possible Joystick Fault	See authorized Pride Provider.
6	Inhibit Active	Unplug charger. Check connections.
5	Right Motor Wiring Fault	Check right motor wiring.
4	Right Motor Disconnected	Check right motor wiring.
3	Left Motor Wiring Fault	Check left motor wiring.
2	Left Motor Disconnected	Check left motor wiring.
1	Low Battery Voltage	Check batteries/battery wiring.

VII. OPERATION

THE MICRODRIVE CONTROLLER

The electronic controller is what you use to operate your power chair. It takes the battery voltage and sends it to the appropriate system. The electronic controller also enables you to monitor battery charge, electronic controller functions, and the condition of your electrical system. Also, it may be used to control some optional systems such as power elevating seats and lights. The Microdrive electronic control system is a modular system. The electronics necessary to operate your power chair are contained in several modules located on different parts of your power chair. Typically, the Microdrive Controller is mounted to one of the armrests. See figure 31. The other components are located on or inside the power base.

The controller supplied with your power chair has been pre-programmed to meet your needs. The program is set using either a personal computer with software provided by the controller manufacturer or with a hand-held programmer, also provided by the controller manufacturer.



WARNING! The controller program can affect speed, acceleration, deceleration, and braking. If it is programmed incorrectly or outside of the safe limits as determined by your healthcare professional, it can create a dangerous situation. Only the power chair manufacturer, an authorized representative of the manufacturer, or a trained service technician should program the controller.

The Microdrive Controller consists of:

1. joystick
2. display pad
3. mode switch
4. on/off switch
5. speed adjustment dial
6. joystick interface module
7. off-board charger/programming socket

Joystick

The joystick controls the direction and speed of your power chair. When you move the joystick from the neutral (center) position, the electromagnetic brakes release and allow the power chair to move. The farther you push the joystick from its neutral position, the faster the power chair moves. When you release the joystick and allow it to return to the neutral position, the electromagnetic brakes engage and the power chair comes to a complete stop.



WARNING! If your power chair begins to move in an unexpected manner, immediately release the joystick. Unless the joystick is damaged, this action should stop your power chair.

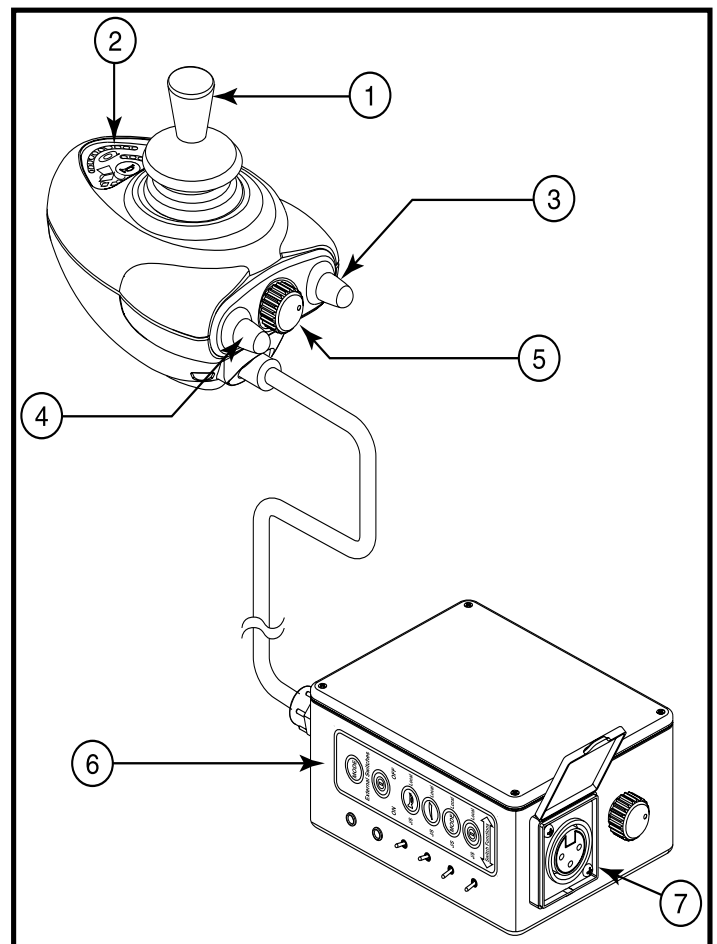

Figure 31. Microdrive Controller

VII. OPERATION

Display Pad

The display pad is located directly in front of the joystick. It contains the horn key, battery condition meter, profile and speed indicator, and the actuator indicator. See figure 32.

Horn Key

The horn key activates the horn.

Battery Condition Meter

The battery condition meter is a 10-segment illuminated display that indicates that the Microdrive is powered on and also gives the status of the batteries, the controller, and the power chair electrical system.

- **Red, yellow, and green lights lit:** Batteries charged; controller and electrical system OK.
- **Red and yellow lights lit:** Charge batteries if possible; controller and electrical system OK.
- **Red lights only lit or slow flash:** Charge batteries as soon as possible; controller and electrical system OK.
- **Rapid flash of lights:** Indicates a fault in the controller or the electrical system. See “Error Codes.”
- **Ripple up and down of lights:** The joystick was not in the neutral position when the controller was turned on. If you get “ripple up and down of lights,” turn off the controller, allow the joystick to return to the neutral position, then turn on the controller.

NOTE: If you still get “ripple up and down of lights,” contact your authorized Pride Provider.

NOTE: When the batteries approach a discharged state, the first red light will begin to slowly flash, reminding you the batteries need to be charged immediately!

Profile and Speed Indicator

The profile and speed indicator is a 5-segment illuminated display that indicates speed setting as well as drive profile.

Actuator Indicator

The actuator indicator is a 4-segment illuminated display that indicates power recline, power tilt, power leg rest, and power elevating seat actuator modes.

Joystick Interface Module

The joystick interface module provides a means to enable or disable the horn button, mode switch, on/off switch, and speed adjustment dial.

NOTE: When a toggle switch is set to “J/S,” the joystick has control of a particular function. When the toggle switch is set to “Local,” control of this function is disabled at the joystick.

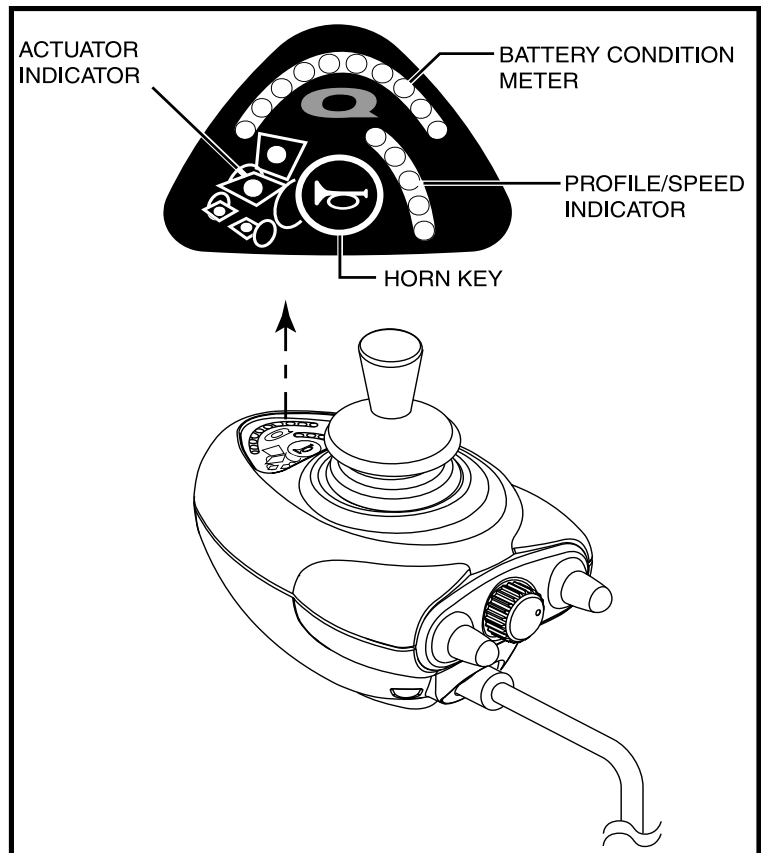

Figure 32. Microdrive Display Pad

VII. OPERATION

Drive Profile Selection

Your Microdrive controller may be programmed for more than one drive profile that allows the system to be custom tailored to your environment.

To select a profile setting:

1. Use the on/off switch to power on the chair and the controller.
2. Press the mode button.
3. Move the joystick left or right to select the desired drive profile. Each of the LEDs indicate a separate profile.

NOTE: The system can be programmed with 5 different profiles.

Speed Adjustment

The Microdrive controller provides a speed control knob to control the speed of the power chair.

To change the speed:

1. Use the on/off switch to power on the chair and the controller.
2. To increase your speed, turn the speed control knob clockwise.
3. To decrease your speed, turn the speed control knob counterclockwise.

Sleep Mode

The Microdrive controller offers a sleep mode feature which will shut off the main power if the joystick remains stationary for a period of five minutes. The battery condition meter will indicate sleep mode by blinking once every five seconds. To restore power and resume operation of the chair, flip the on/off switch twice.

Thermal Rollback

The Microdrive controller is equipped with a thermal rollback circuit which monitors the temperature of the chair's motors and controller. If either exceeds 122° F, the controller reduces the motor voltage by 5 volts for every degree over. This reduces the chair's speed and allows a cool down period. Once the temperature returns to a safe level, the chair will resume normal operation.

Error Codes

In addition to indicating the current state of battery charge, the battery condition meter can also indicate possible problems with your power chair's electrical system. If any of the battery condition meter lights are flashing rapidly, the controller may be indicating an error. Error codes are displayed as a number of flashing lights. For instance, if the first light is flashing rapidly, the battery voltage is nearly depleted. The table below identifies the individual error codes, probable causes, and possible solutions. If you get one of these error codes, contact your authorized Pride Provider.

VII. OPERATION

FLASHING LIGHTS	DIAGNOSIS	SOLUTION
10	High Battery Voltage	Check batteries.
9	Solenoid Brake Fault	Check motor/brake wiring.
8	Possible Controller Fault	See authorized Pride Provider.
7	Possible Joystick Fault	See authorized Pride Provider.
6	Inhibit Active	Unplug charger. Check connections.
5	Right Motor Wiring Fault	Check right motor wiring.
4	Right Motor Disconnected	Check right motor wiring.
3	Left Motor Wiring Fault	Check left motor wiring.
2	Left Motor Disconnected	Check left motor wiring.
1	Low Battery Voltage	Check batteries/battery wiring.

VIII. CARE AND MAINTENANCE

CARE AND MAINTENANCE

Your Jazzy 1103 Ultra is a sophisticated power chair. Like any motorized vehicle, it requires routine maintenance checks. You can perform some of these checks, but others require assistance from your authorized Pride Provider. Preventive maintenance is very important. If you follow the maintenance checks in this section as scheduled, you can help ensure that your power chair gives you years of trouble-free operation. If you have any doubt as to your power chair's care or operation, contact your authorized Pride Provider.



WARNING! Prevent injury. Do not service the power chair when the seat is occupied.

Your power chair, like most electrical equipment, is susceptible to damage from the elements. Avoid damp areas of any kind.



WARNING! Direct exposure to water or dampness could cause the power chair to malfunction electronically and mechanically. Water can cause electrical components to corrode and the chair's frame to rust.

Should your power chair come in contact with water:

1. Dry your power chair as thoroughly as possible with a towel.
2. Allow your power chair to sit in a warm, dry place for twelve hours to allow unseen water to evaporate.
3. Check the joystick operation and the brakes before using your power chair again.
4. If any inconsistencies are found, take your power chair to your authorized Pride Provider.

Temperature

- Some of the parts of your power chair are susceptible to extreme changes in temperature. Always keep your power chair between the temperatures of 18° F and 122° F.
- In extremely cold temperatures the batteries may freeze. The specific temperature at which they freeze depends on a number of factors, such as battery charge, usage, and composition of the batteries (e.g., AGM or Gel-Cell).
- Temperatures above 122° F may cause your power chair to operate at a reduced speed. This reduced speed is a safety feature built into the controller that helps prevent damage to the motor and other electrical components. See VII. "Operation."

General Guidelines

- Avoid knocking or bumping the controller, especially the joystick.
- Avoid prolonged exposure of your power chair to extreme conditions, such as heat, cold, or moisture.
- Keep the controller clean.
- Check all connectors to ensure that they are all tight and secured properly.
- Make sure pneumatic drive tires are inflated to **35 psi (2.4 bar)**.



WARNING! Overinflating tires can cause them to explode and can result in personal injury.

WARNING! Do not use a high pressure hose to inflate your tires.

- Use a rubber conditioner on the tire sidewalls to help preserve them.



WARNING! Never use a rubber conditioner on the tread area of the tires; doing so may make the tires slippery and cause your power chair to skid.

- The body shroud has been sprayed with a clear sealant coating. You can apply a light coat of car wax to help it retain its high-gloss appearance.

VIII. CARE AND MAINTENANCE

- Check all electrical connections. Make sure they are tight and are not corroded. Batteries must sit flat within the battery tray, with the battery terminals facing inward, toward each other. Refer to the battery wiring label for the correct wiring layout.
- All wheel bearings are prelubricated and sealed. They require no subsequent lubrication.

Daily Checks

- With the controller turned off, check the joystick. Make sure it is not bent or damaged and that it returns to the neutral position when you release it. Check the rubber boot around the base of the joystick for damage. Visually inspect the boot. Do not handle or try to repair it. See your authorized Pride Provider if there is a problem.
- Visually inspect the controller cable. Make sure that it is not frayed, cut, or has any wires exposed. See your authorized Pride Provider if there is a problem.
- Check for flat spots on solid tires. Flat spots could adversely affect stability.

Weekly Checks

- Disconnect and inspect the controller from the power pod. Look for corrosion. Contact your authorized Pride Provider if necessary.
- Ensure that all parts of the controller system are securely fastened to your power chair. Do not overtighten any screws.
- Check for proper tire inflation. There should be **35 psi (2.4 bar)** in each tire. If a tire does not hold air, see an authorized Pride Provider for replacement of the tube.
- Calibrate the joystick if a noticeable difference in performance is detected or if the joystick does not operate properly. To calibrate the joystick, power off the unit, place the joystick in the neutral position, and power the unit back on. If a problem still exists with your joystick's performance, contact your authorized Pride Provider.
- Check the brakes. This test should be carried out on a level surface with at least three feet of clearance around your power chair.

To check the brakes:

1. Turn on the controller and turn down the speed level of your power chair.
2. After one second, check the battery condition meter. Make sure that it remains on.
3. Slowly push the joystick forward until you hear the electric brakes click. Immediately release the joystick. You must be able to hear each electrical brake operating within a few seconds of joystick movement. Repeat this test three times, pushing the joystick backwards, then left, and then right.

Monthly Checks

- Check that the anti-tip wheels do not rub the ground when you operate the power chair. Adjust them as necessary. See V. "Comfort Adjustments."
- Check for extreme wear on the anti-tip wheels. Replace them as necessary.
- Check for drive tire wear. See your authorized Pride Provider for repair.
- Check the caster wheels for wear. Replace them as necessary.
- Check the caster forks for damage or fluttering which indicates that they may need to be adjusted or have the bearings replaced. See your authorized Pride Provider for repair.
- Keep your power chair clean and free of foreign material, such as mud, dirt, hair, food, drink, etc.

Yearly Checks

Take your power chair to your authorized Pride Provider for yearly maintenance. This helps ensure that your power chair is functioning properly and helps prevent future complications.

VIII. CARE AND MAINTENANCE

Storage

Your power chair should be stored in a dry place, free from temperature extremes. When storing, disconnect the batteries from the power chair. See VI. "Batteries and Charging."



WARNING! If you fail to store the unit properly, the frame can rust and the electronics can be damaged.

Disposal of Your Power Chair

Your power chair must be disposed of according to applicable local and national statutory regulations. Contact your local waste disposal agency or authorized Pride Provider for information on proper disposal of power chair packaging, metal frame components, plastic components, electronics, and batteries.

Cleaning and Disinfection

■ Use a damp cloth and mild, non-abrasive cleanser to clean the plastic and metal parts of your power chair. Avoid using products that may scratch the surface of your power chair.

■ If necessary, clean your product with an approved disinfectant. Make sure the disinfectant is safe for use on your product before application.

WARNING! Prevent personal injury and product damage! Follow all safety instructions for the proper use of the disinfectant before applying it to your product.



WARNING! Never hose off your power chair or place it in direct contact with water. Your power chair has a painted, ABS plastic body shroud that allows it to be easily wiped clean with a damp cloth.

WARNING! Never use any chemicals to clean a vinyl seat, as they may cause the seat to become slippery or dry out and crack. Use soapy water and dry the seat thoroughly.

Wheel Replacement

If you have pneumatic tires and you have a flat tire, you can replace the tube. If your chair is equipped with a solid tire insert, then you must replace the whole wheel assembly. Replacement tires, tubes, and wheel assemblies are readily available through your authorized Pride Provider.



WARNING! To avoid possible injury, be sure that the controller's power is turned off and the power chair is not in freewheel mode before performing this procedure.

WARNING! Completely deflate the tire before attempting repair.

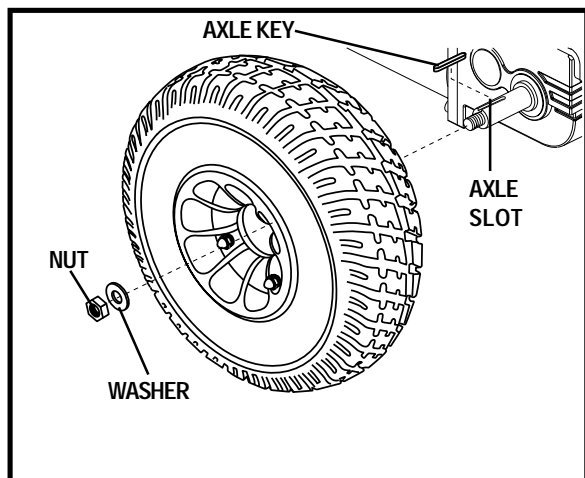

Figure 33. Jazy 1103 Ultra Drive Wheel

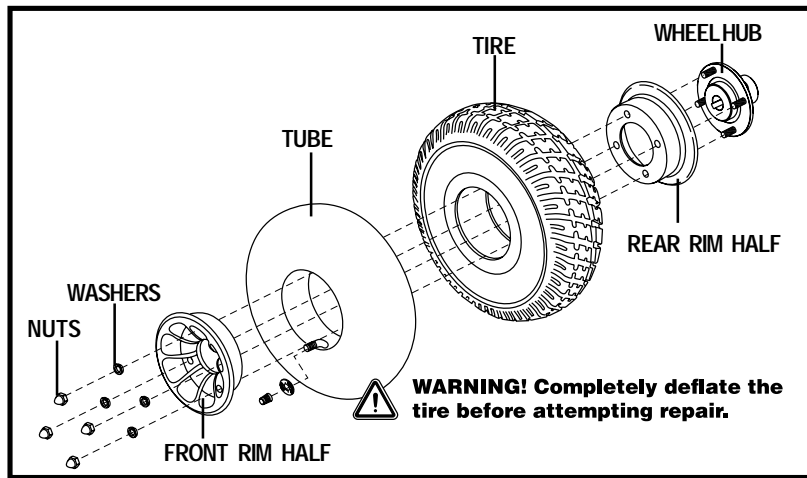

Figure 34. Jazy 1103 Ultra Drive Wheel Disassembled

VIII. CARE AND MAINTENANCE

Follow these easy steps for a quick and safe repair for both pneumatic and solid tires:

1. Turn off the power to the controller.
2. Set the power chair up on blocks.
3. If you are changing a pneumatic tire, completely deflate it before removing the wheel.
4. Remove the drive wheel nut and washer from the axle.
5. Pull the wheel off the axle.
6. Remove the nuts and washers from the wheel hub to separate the rim halves. See figure 33.
7. Remove the old tube from the pneumatic tire and replace it with a new tube or replace the entire assembly if it is a solid tire. See figure 34.
8. Refasten the rim halves.
9. Slide the wheel back onto the axle. Make sure that the key is in the axle slot.
10. Reinstall the drive wheel nut and washer onto the axle and tighten.
11. Inflate the pneumatic tire to **35 psi (2.4 bar)**.
12. Remove the power chair from the blocks.

Battery Replacement

A battery wiring diagram is printed on a decal located on the battery tray. See figure 35.

WARNING! Prevent injury. Do not replace the batteries when the seat is occupied.

WARNING! Battery posts, terminals, and related accessories contain lead and lead compounds. Wear goggles and gloves when handling batteries and wash hands after handling.



WARNING! Power chair batteries are heavy. See specifications table. If you are unable to lift that much weight, be sure to get help. Lifting beyond your capacity can result in personal injury.

WARNING! Prevent injury and/or equipment damage. Do not mix or match new and old batteries. If you encounter a situation where one battery needs to be replaced, then replace both batteries. Refer to specification table in this manual and the manual supplied with the battery charger for recommended type and capacities.

To replace the batteries:

1. Turn off the power to the controller.
2. Make sure that the power chair is in drive mode. See III. “Your Power Chair.”
3. Loosen the rear shroud fasteners. See figure 6.
4. Remove the rear shroud.
5. Unplug the battery connector. See figure 35.
6. Disconnect the wiring harness from the rear battery.
7. Disconnect the controller from the power pod. See figure 7.
8. Pull up on the friction lock lever and remove the seat.
9. Remove the retaining pin from the foot platform and lift the platform off of the power base. See figure 17.
10. Turn the yellow fastener and remove the center shroud. See figure 6.
11. Disconnect the wiring harness.
12. Remove the rear battery.
13. Slide the front battery tray forward.
14. Disconnect the wiring harness from the front battery.
15. Remove the front battery.
16. Place a new rear battery onto the power base. Make sure that the terminals are facing forward.

VIII. CARE AND MAINTENANCE

17. Place a new battery in the front of the battery tray. Make sure that the terminals are facing each other.



WARNING! Prevent injury. Use only the quick disconnect harness supplied with your power chair. It has a thermal fuse on each lead.

18. Connect the wiring harnesses to the front battery. See figure 35.



WARNING! Prevent injury. Make sure you tighten the fasteners so that the connections are secure.

19. Connect the wiring harnesses to the rear battery. See figure 35.

20. Slide the battery tray back into the power base.

NOTE: Make sure that the power pod is out of the way when reinstalling the batteries.

21. Place the center shroud back on top of the power base and secure the yellow fastener.

22. Reinstall the foot platform.

23. Reinstall the seat.

24. Reconnect the battery connector.

25. Reconnect the controller to the power pad.

26. Reinstall the rear shroud and tighten the fasteners.

27. Charge the batteries. See VI. "Batteries and Charging."

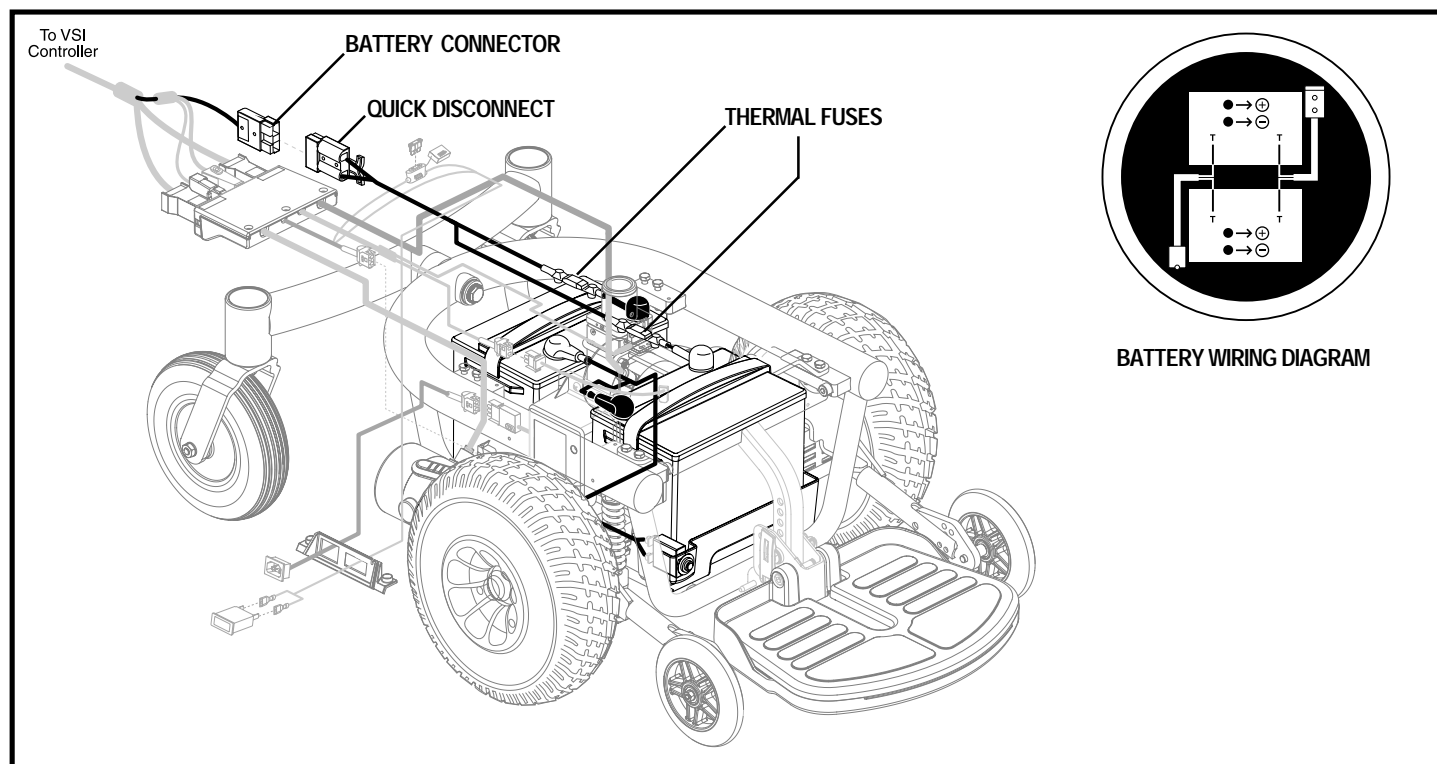

Figure 35. Jazzy 1103 Ultra Battery Connections

VIII. CARE AND MAINTENANCE

When to See Your Authorized Pride Provider for Service

The following symptoms could indicate a serious problem with your power chair. If necessary, contact your authorized Pride Provider. When calling, have the model number, serial number, nature of the problem, and the error code if available.

- Motor noise
- Frayed harnesses
- Cracked or broken connectors
- Uneven wear on any of the tires
- Jerky motion
- Pulling to one side
- Bent or broken wheel assemblies
- Does not power up
- Powers up, but does not move

Corrective Maintenance

If the battery condition meter does not light up when you turn on the power:

- Check the harness connections. Make sure they are tight.
- Check the circuit breaker. Reset it if necessary.
- Check the battery connections.

If the above conditions prove normal, you can load test the batteries with a battery load tester. These testers are available at automotive parts stores. Disconnect both batteries before load testing and follow the directions that come with the load tester. If either one of the batteries fails the load test, replace both of them. If your power chair still does not power up, contact your authorized Pride Provider.

I X . W A R R A N T Y

LIFETIME LIMITED WARRANTY

For the lifetime of your power chair from the date of purchase, Pride will repair or replace at our option to the original purchaser, free of charge, any of the following parts found upon examination by an authorized representative of Pride to be defective in material and/or workmanship:

Structural frame components, including:

- Main Frame
- Fixed-position seat post

TWO-YEAR LIMITED WARRANTY

For two (2) years from the date of purchase, Pride will repair or replace at our option to the original purchaser, free of charge, any of the following parts found upon examination by an authorized representative of Pride to be defective in material and/or workmanship:

Electronic components, including:

- Charger Assembly
- Controller
- Joystick

Main frame assemblies, including:

- Anti-tip forks
- Caster forks
- Caster beam
- Metal seat framing

Other components, including:

- Foot riggings
- Electrical Harness
- Foot rigging mounting brackets

18-MONTH LIMITED WARRANTY

For eighteen (18) months from the date of purchase, Pride will repair or replace at our option to the original purchaser, free of charge, any of the following parts found upon examination by an authorized representative of Pride to be defective in material and/or workmanship:

- Motor/gearbox assembly
- Power seat actuator

ONE-YEAR LIMITED WARRANTY

For one (1) year from the date of purchase, Pride will repair or replace at our option to the original purchaser, free of charge, any of the following parts found upon examination by an authorized representative of Pride to be defective in material and/or workmanship:

- Accessories
- Brakes (electronic function ONLY)

SIX-MONTH LIMITED WARRANTY

For six (6) months from the date of purchase, Pride will repair or replace at our option to the original purchaser, free of charge, any of the following parts found upon examination by an authorized representative of Pride to be defective in material and/or workmanship:

- Bearings and bushings
- Plastic components, except body

The battery is covered by a separate six-month warranty, provided by the battery manufacturer. The batteries are not warranted by Pride.

IX . WARRANTY

RECONDITIONED UNITS WARRANTY

All reconditioned units are covered by a six-month warranty from Pride effective from the date of purchase.

WARRANTY EXCLUSIONS

This warranty does not extend to those items which may require replacement due to normal wear and tear.

- ABS Plastic shrouds
- Motor brushes
- Upholstery and seating
- Brake Pads
- Tires and tubes
- Fuses/Bulbs
- Circumstances beyond the control of Pride
- Labor, service calls, shipping, and other charges incurred for repair of the product, unless specifically authorized, IN ADVANCE, by Pride Mobility Products Corporation
- Repairs and/or modifications made to any part without specific consent from Pride

Exclusions also include components with damage caused by:

- Contamination
- Abuse, misuse, accident, or negligence
- Battery fluid spillage or leakage
- Commercial use, or use other than normal
- Improper operation, maintenance, or storage

NOTE: Gradual deterioration in performance because the battery has been left in a discharged state, left in cold conditions for an extended period of time, or worn out through heavy use is not covered.

SERVICE CHECKS AND WARRANTY SERVICE

Warranty service must be performed by an authorized Pride Provider. Do not return faulty parts to Pride without prior written authorization. All transportation costs and shipping damage incurred while submitting parts for repair or replacement are the responsibility of the purchaser.

Failure to follow the instructions, warnings, and notes in the owner's manual and those located on your Pride product can result in personal injury or product damage and will void Pride's product warranty.

There is no other express warranty.

IMPLIED WARRANTIES

Implied warranties, including those of merchantability and fitness for a particular purpose, are limited to one (1) year from the date of purchase and to the extent permitted by law. Any and all implied warranties are excluded. This is the exclusive remedy. Liabilities for consequential damages under any and all warranties are excluded.

Some states do not allow limitations on how long an implied warranty lasts or do not allow the exclusion of limitation incidental or consequential damages. The above limitation or exclusion may not apply to you.

This warranty gives you specific rights, and you may also have other rights which vary from state to state.

Please fill out and return the product registration card to Pride. This will aid Pride in providing the best possible technical and customer service.

Jazzy Power Chairs®

How a Power Chair Should Feel™



Quality Control- Jazzy 1103 Ultra

Thank you for making the Jazzy 1103 Ultra your choice in power chairs. The following checkmarks indicate that we have thoroughly inspected and test driven your power chair.



Inclusion of all Parts

Joystick Serial Number

Controller Serial Number

Left Motor Serial Number

Right Motor Serial Number

Fit and Finish

Performance

Pride keeps a more detailed report on file at the factory.

Date Inspected

Inspector

*** I NFMANU2429 ***

Product Serial Number