

SPORTSTER SE

User's Manual

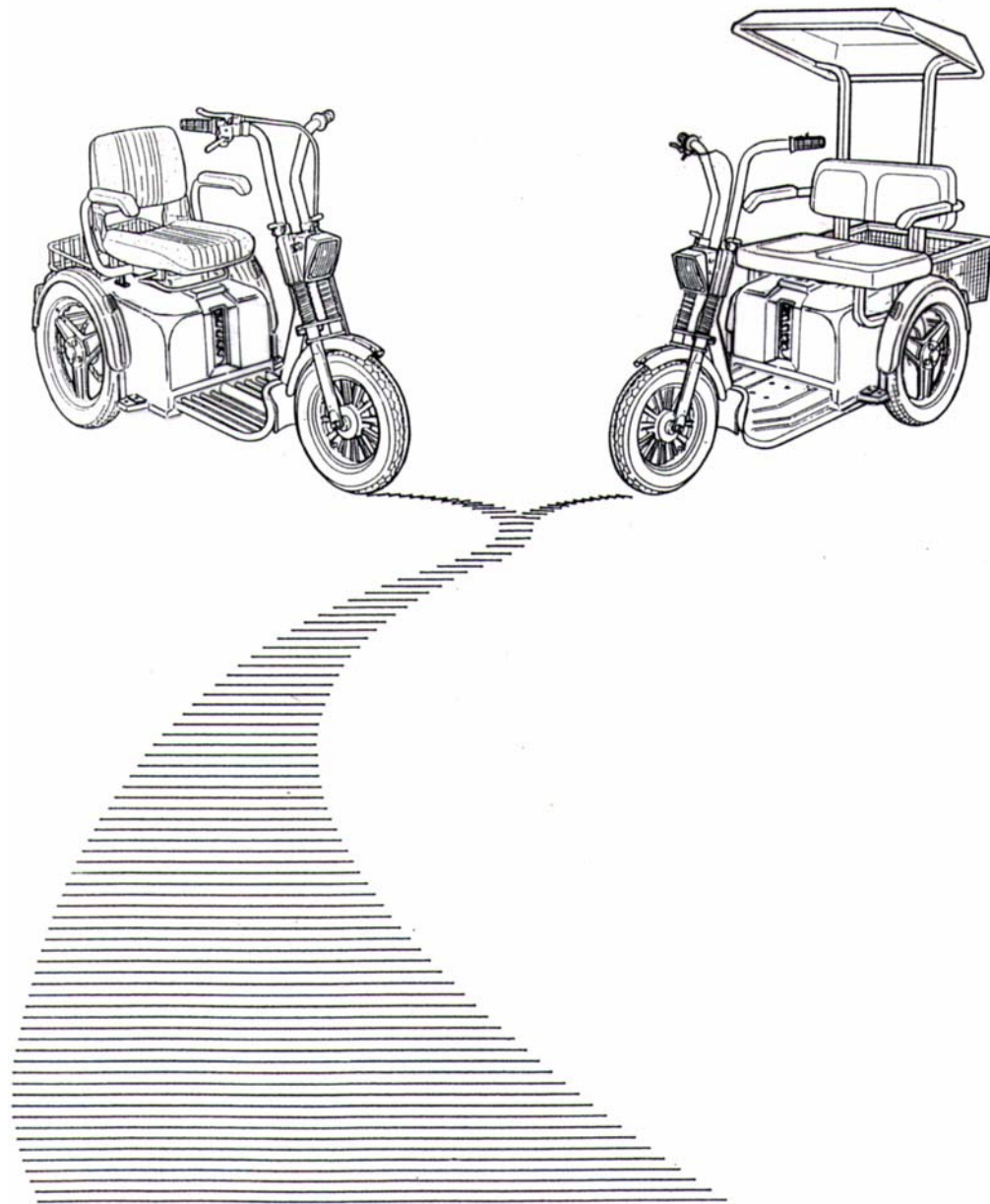

AFI

KIM ELECTRIC VEHICLES

KIBBUTZ AFIKIM 15148, ISRAEL TEL: 972-4-6754814, FAX: 972-4-6751456

e-mail: mainbox@afiscooters.com

websites: www.afiscooters.com

P/N PR00056

WARNING

Read the User's Manual carefully before operating the SPORTSTER. If you do not fully understand any part of this Manual, please contact your dealer or any of our Service Centers - as injury or damage may occur from misuse!

WARNING

Electromagnetic Interference ("EMI") can cause powered vehicles to behave erratically, which could be dangerous to the user. For your safety and protection, it is **IMPERATIVE** that you take time to read Chapter 6 ("EMI WARNING") before operating the SPORTSTER.

Serial Number and Manufacturer's data are fixed to the back side of the Headlight Housing (subject to change as per local ordinances).

Date: April 2001
Edition: 02
Products: SE - Single Seat
SE - XXL Seat (65 cm)
SE - Wide Seat (79 cm)

CE CERTIFICATION

The Afikim Electric Vehicles Ref. Registration
Number with the Competent Authority (UK) is:

CA 000292.

Our Authorized Representative with the
Competent Authorities is:

MEDES LTD.
POB 231
Stanmore, Middlesex, HA7 4YA,
England

TEL/FAX: 0044-181-954-9964

CONTENTS

CHAPTER 1 - Overview Of The Sportster SE	1
Safety Instructions	2
General Description Of The Sportster SE.....	3
CHAPTER 2 - Adjustment & Operating Instructions.....	6
CHAPTER 3 - Maintenance.....	12
CHAPTER 4 - Charging.....	15
CHAPTER 5 - Troubleshooting and Fault Repair	17
CHAPTER 6 - EMI Warning.....	19

CHAPTER 1 - OVERVIEW OF THE SPORTSTER SE

Main features:

Congratulations on choosing the SPORTSTER as your electrically powered vehicle.

The SPORTSTER is easy to operate. The relatively large wheels enable driving on unpaved roads, over rough terrain and to overcome obstacles as high as 4" (10 cm). The SPORTSTER can climb slopes up to 21% - Single, 18% - Double. The braking system stops the SPORTSTER smoothly and a short distance after the Operating Lever is released.

A standard hand brake is also provided for backup. The Seat is spacious, comfortable and can be rotated for easy access (standard Seats). All controls are conveniently located and are simple to operate.

Under normal conditions the SPORTSTER can travel approximately 40 km (25 miles) before the batteries require recharge.

The SPORTSTER SE is developed to use dry or gel batteries only.

The SPORTSTER SE Series includes -

- Model SE -
- Single Seat
 - XXL Seat (65 cm)
 - Wide Seat (79 cm)

Please see Figure No. 1 for detailed specifications.

SAFETY INSTRUCTIONS

1. Please note and strictly adhere to the following Safety Instructions. Additional **Warnings** and **Notices** are printed in this User's Manual; **it is imperative that you read carefully all chapters of this Manual before operating the SPORTSTER.** It is also advisable to refresh your memory by re-reading this Manual periodically.
Use gel/dry batteries only.
2. **Get acquainted** with the SPORTSTER and its operational features before driving it.
3. **Drive slowly** (Place Speed Selector in position 1) until you get used to the SPORTSTER, to its various functions, safety features, and to its braking capabilities and limitations.
4. **Watch carefully** for pedestrians and drive your SPORTSTER accordingly. In crowded areas always drive with the Speed Selector at Low Speed (position 1).
5. Drive **only where permitted** according to all applicable local laws and ordinances.
6. **Never remove any of the SPORTSTER safety** parts like Antitip, Device, Fenders, or Emergency Brake lever
7. **DO NOT** turn the Main Key Switch to "OFF" position while in motion; this may cause abrupt and excessive deceleration which in turn may cause injury to the user and damage to the SPORTSTER.
8. Do not release the Manual Release Lever of the Electromagnetic Brake when the SPORTSTER is on a slope.
9. The load in the Rear Basket should not exceed 20 kg (44 lbs).
10. The SPORTSTER is designed and built to carry ONE person only on the Single Seat model, or two persons on the Double Seat model.
Never operate it with an additional person on board, not even a child.
11. Do not change the Speed Selector position while driving.
12. **NEVER** use the SPORTSTER for climbing up or riding down stairs.
13. If for any reason the SPORTSTER does not stop when you release the Operating Lever, immediately use the Hand Brake to stop the SPORTSTER and turn the Main Key Switch to "OFF".
Contact your dealer immediately.
14. **NEVER** use a hose for cleaning. This may severely damage the power and electronic components. Use only a damp cloth and mild detergent.

WARNING !!!

Special care must be taken to prevent children from operating the SPORTSTER.

GENERAL DESCRIPTION OF THE SPORTSTER SE

Note: 1. The numbers in parentheses refer to the parts illustrated on Figure 1.

Handlebars (2)	<p>There are two separate and independently adjustable handlebars, one of which houses the controls for the SPORTSTER. Your SPORTSTER is delivered to you with right-hand controls. (Left-hands controls can be ordered through your dealer).</p> <p>NOTE : On the Double Seat model the left handlebar is shorter to allow for easier steering by the driver with 2 people on board. For a single user two handlebars of the same length can be supplied. Ask your dealer.</p>
Headlight (3)	
Charging Socket (4)	The socket is used to connect the charger plug for batteries charging.
Seat (6)	<p>The Single SPORTSTER Seat is equipped with folding armrests (1) to allow convenient access to the Seat. The Seat itself can be rotated. The upholstery may be removed for cleaning. (A deluxe orthopedic adjustable Seat is also available. Ask your dealer).</p> <p>The Double SPORTSTER Seat is equipped with folding armrests (1) as in the Single Seat model and can be tilted to make service more accessible. It can also be supplied with a Canopy (10) for protection from rain and sun.</p>
Fuses (5)	<p>5A - Main Fuses 2x40A – Semi Automatic 5B - Light Fuse (3A) 6x32 option - Semi Automatic 5C - Charging Fuse 15A – Semi Automatic</p>
Seat Rotation Lever (7)	The Lever is used to swivel the Seat 45 degrees in either direction, to ease the driver's access to the Seat.
Rear Basket (8) (Optional for Single Seat model and standard for Double Seat model)	For carrying parcels and personal effects. Maximum load 20 kg (44 lbs).
Serial No.	Serial Number and Manufacturer's data are located on the rear side of the main lamp, and of the back of rear tray.
Manual Release Lever of Electromagnetic Brake (11)	Located under the seat at the rear right of the SPORTSTER, the Electromagnetic Brake Manual Release Lever allows free movement of the SPORTSTER. To release, simply push the brake lever forward. To engage brake, pull lever backward. When lever is released the vehicle <u>can not</u> be operated.

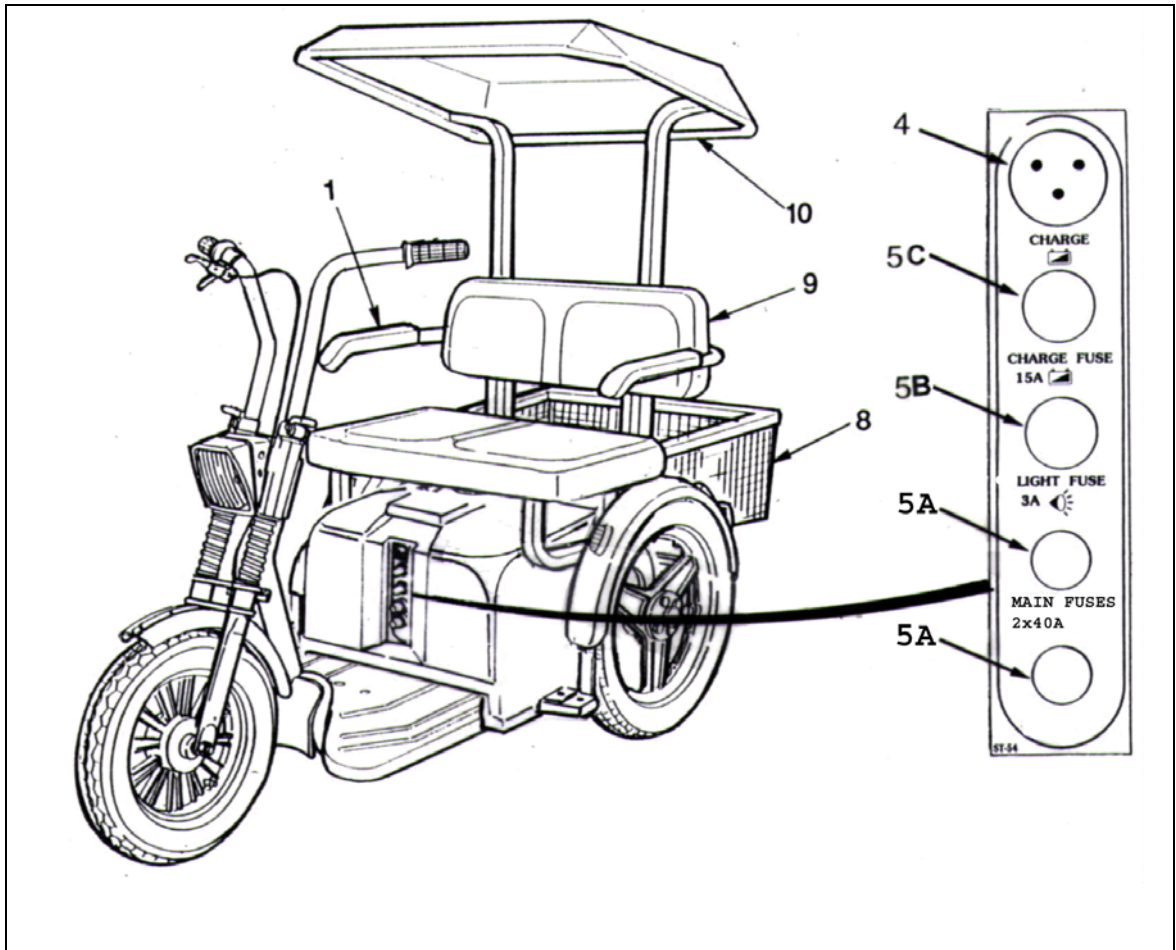
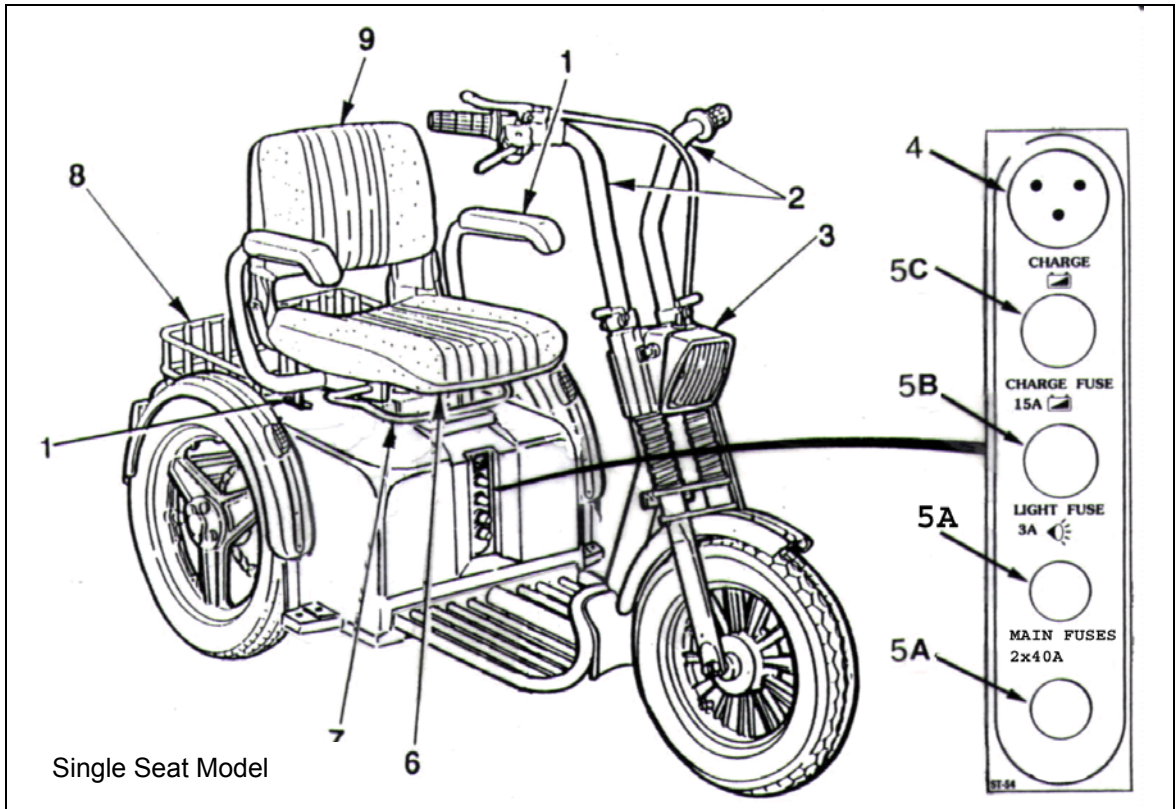

Figure 1

TECHNICAL SPECIFICATIONS

MODEL No. :		SE Single Seat		SE XXL Seat (65 cm)		SE Wide Seat (79 cm)	
		Metric	USA	Metric	USA	Metric	USA
Dimensions *	Length (without rear basket)	150 cm	59"	170 cm	67"	170 cm	67"
	Length (with rear basket)	175 cm	69"				
	Width	72 cm	28"	76 cm	30"	90 cm	35"
	Height (for transport: handles, seat and front wheel removed)	77 cm	30.5"	77 cm	30.5"	77 cm	30.5"
	Ground clearance	12 cm	5"	12 cm	5"	12 cm	5"
Weights *	Total, without batteries	75 kg	165 lbs	90 kg	198 lbs	90 kg	198 lbs
	Total, with batteries	115-125 kg	254-276 lbs	130-140 kg	287-309 lbs	130-140 kg	287-309 lbs
	Maximum load (including rear basket load)	200 kg	440 lbs	200 kg	440 lbs	200 kg	440 lbs
Speed **	Forward (Speed selector position No. 2)	10 km/h	6.2 mp/h	10 km/h	6.2 mp/h	10 km/h	6.2 mp/h
	Forward (Speed selector position No. 1)	6 km/h	3.7 mp/h	6 km/h	3.7 mp/h	6 km/h	3.1 mp/h
	Reverse	6 km/h	3.7 mp/h	6 km/h	3.7 mp/h	6 km/h	3.1 mp/h
Climbing ability	Maximum slope (100 kg- 220 lbs load)	21%		18%		18%	
	Obstacles	12 cm	5"	12 cm	5"	12 cm	5"
Tires (pneumatic)	Front tire size		10x2.75"		10x2.75"		10x2.75"
	Rear tires size		14x2.75"		14x2.75"		14x2.75"
	Pressure		20-25 psi		20-25 psi		20-25 psi
Towing	Level surface, driver 75 kg (165 lbs)	100 kg	220 lbs	100 kg	220 lbs	100 kg	220 lbs
Batteries ***	Gel/dry batteries only	60-70 Ah	2x12 V	60-70 Ah	2x12 V	60-70 Ah	2x12 V
Travel distance	Fully charged batteries, level surface, driver 75 kg (165 lbs)	40-45 km	25.0 miles	40-45 km	25.0 miles	40-45 km	33.5 miles

All technical specifications are subject to change without prior notice.

All dimensions are in round figures.

* Dimensions and weight do not include SPORTSTER Canopy.

** The maximum speed can be adjusted by the manufacturer to allow for lower or higher maximum speed (i.e., max. 15 km/h - 9.3 mp/h).

*** Deep cycle batteries. Consult your dealer for other sizes.

CHAPTER 2 - ADJUSTMENT & OPERATING INSTRUCTIONS

(Reference numbers refer to the figures at the bottom of each page)

Adjusting the Handlebars	Adjust angles and height of both handlebars as follows: <ul style="list-style-type: none">• Release the Handlebars Clamp (1), which secures the handlebars in place, by turning the cam Lever outward from the vehicle.• Adjust the height and angle of your handlebars, by turning, while raising or lowering the handlebars.• Tighten handlebars at the desired height and direction: secure the Handlebars Clamp (1) by turning cam Lever inward.
Adjusting the Hand Brake	The hand brake cable mechanism can be adjusted by any authorized serviceman, dealer or by any professional authorized to adjust hand brakes mounted on bicycles or motorcycles. The Hand Brake is part of your safety system. DO NOT adjust the Hand Brake by yourself - get professional assistance!
Seating into the SPORTSTER	Before driving the SPORTSTER make sure that the Charging Plug is disconnected from the Charging Socket (3). Note: While the Charging Plug is inserted in the Charging Socket, the unit cannot be operated. Lift the Lever (4) upward, rotate the Seat (5) and raise the Armrest (2) to give you easy access to the Seat.

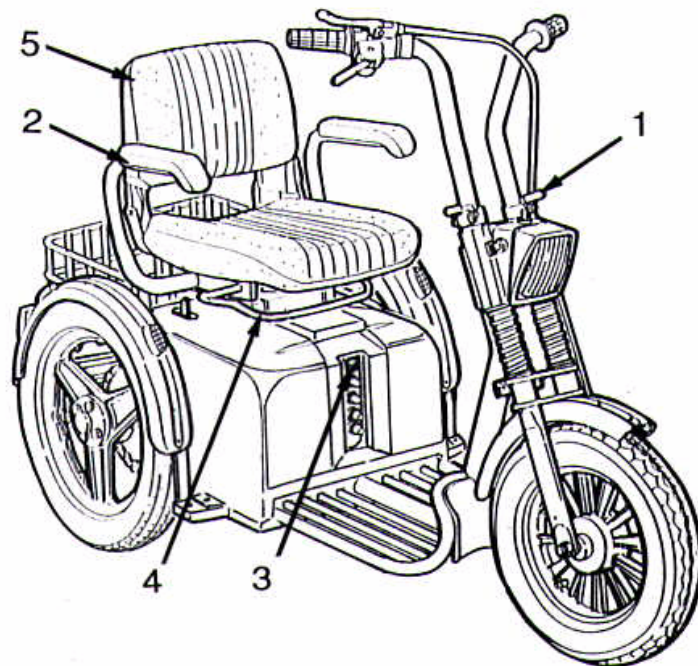

Key Switch

- The SPORTSTER has a Main Key Switch (9) - located on the right side of the Headlight Housing.

The Main Key Switch has two positions:

- “OFF” - The SPORTSTER cannot be driven and the Electromagnetic Brake is locked.
- “ON” - Power is supplied to the SPORTSTER. The Electromagnetic Brake releases automatically when the Operating Lever is squeezed.

To operate the SPORTSTER, insert the key into the Main Key Switch and turn it to “ON” (clockwise). The switch will remain in this position and the green (2) light will be lit.

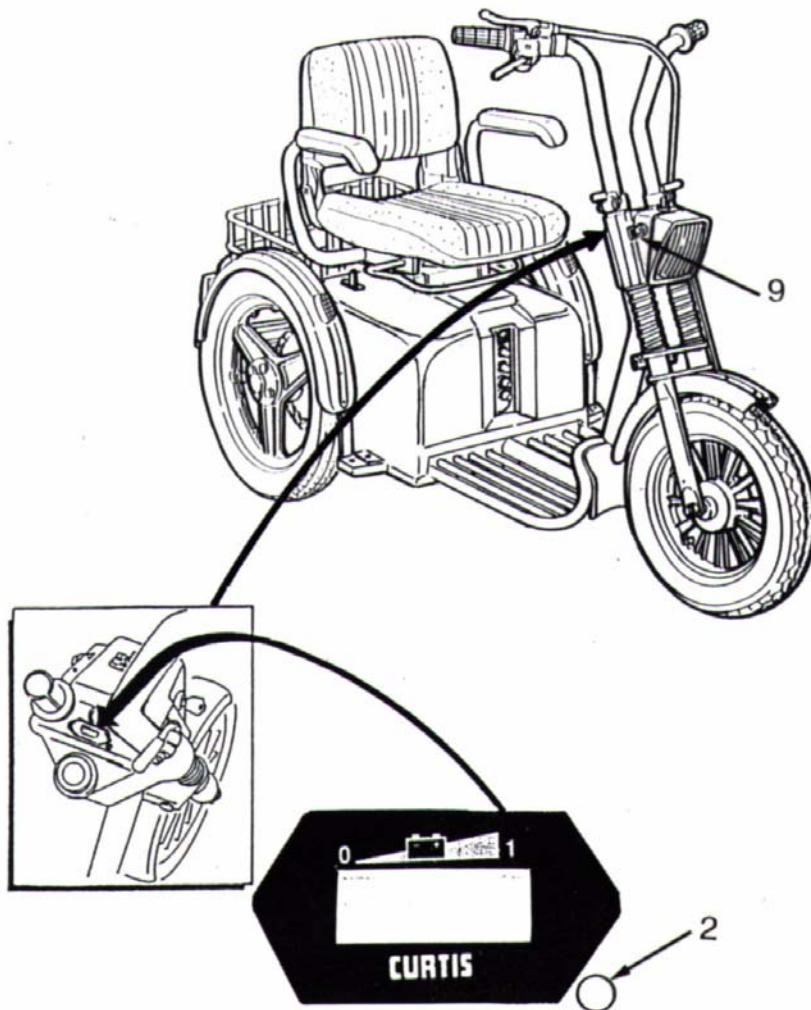

Automatic Shut Off

When Key Switch is at “ON” position, after a few minutes (about 20 minutes) without using the Operating Lever, the control system will be shut off automatically to save battery energy. In such cases, to restart control system, turn Main Key Switch “OFF” and “ON” again.

<p>Battery Status Indicator</p>	<p>The Battery Status Indicator (1) located on top of the Headlight Housing shows you the remaining capacity of the batteries. When the indicator shows that mid-half capacity remains, recharge batteries as soon as possible. When the indicator points that to first or second segment on the left there are only about 5 km (3 miles) to go.</p>
<p>Fault Indicator</p>	<p>When the green light of the Fault indicator (2) is lit, the vehicle is "ready". When the Fault Indicator (2) is Green/Red Flashing the Vehicle is in Fault condition or the brake manual lever is released. (The Flashing Code can be Decoded by technician).</p>
<p>Forward/Reverse Selector</p>	<p>The Forward/Reverse Selector (14) is located on the handlebar. Select the desired direction (as marked). In reverse mode, a warning buzzer sounds automatically (in certain models only and subject to local ordinances).</p> <p>Warning: Do not change Selector position while the SPORTSTER is in motion.</p>

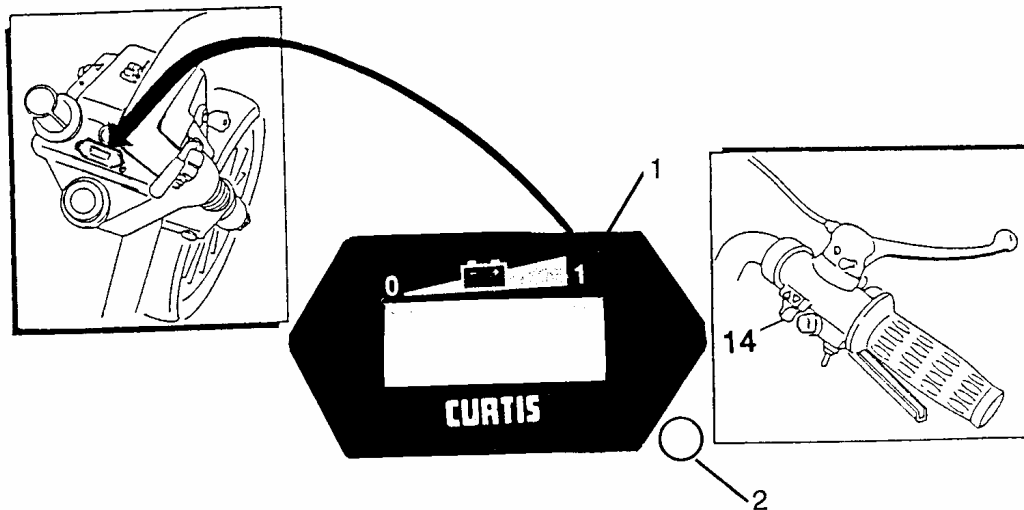

Speed Range Selector	<p>The Speed Range Selector (16) is located on the left side of the Headlight Housing. It has two positions:</p> <ul style="list-style-type: none"> • Mark “1” (lower position): Low speed - up to 6 km/h (3.1 mph). • Mark “2” (upper position): High speed - 10 km/h (6.2 mph). <p>Do not shift the selector while the SPORTSTER is in motion.</p> <p>Note: When driving the SPORTSTER inside a building or in a crowded area, use only position 1 (Low speed).</p>
Operating Lever (red) and Manual Hand Brake	<p>To start driving, squeeze the Operating Lever (18) gently until you reach the desired speed.</p> <p>The speed is directly proportional to the deflection of this Lever .</p> <p>To stop - release the Operating Lever (18). The SPORTSTER will stop gradually.</p> <p>Additionally, emergency braking is possible using the Manual Hand Brake (17). Squeeze Hand Brake and use Button (21) to lock it (USE THIS FOR PARKING). Squeeze Hand Brake again to release the button.</p>
Signaling	<p>Before turning, shift the “Turn Signal Switch” (19), on the Handlebar to the desired direction - left for left, right for right. This will activate blinking lights on the rear fenders. A warning buzzer also sounds (in certain models only and subject to local ordinances).</p>

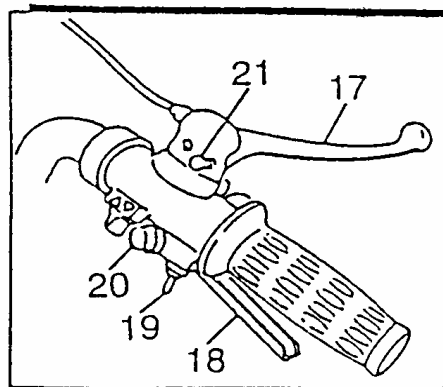
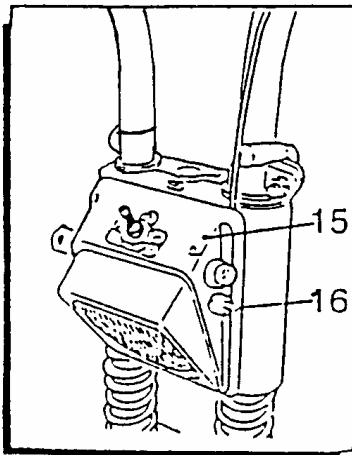

<p>Horn/Buzzer (in certain models only)</p>	<p>Push Button (20) activates a buzzer. The buzzer sounds automatically under the following conditions (<i>subject to change where prohibited by law</i>):</p> <ol style="list-style-type: none"> 1. When reversing. 2. When operating the “Turn Signal Switch” (Right or Left). 3. When the “Emergency Electromagnetic Brake Lever ” is operated.
<p>Headlight Switch</p>	<p>Turn on the Headlight (24) with Light Switch (23). This switch activates both the Headlight and the Rear Lights (28).</p>
<p>Hazard Warning</p>	<p>The Hazard Button (20) operates all flashing lights on the SPORTSTER. Pushing the button once turns the lights ON. A second push turns them OFF.</p>

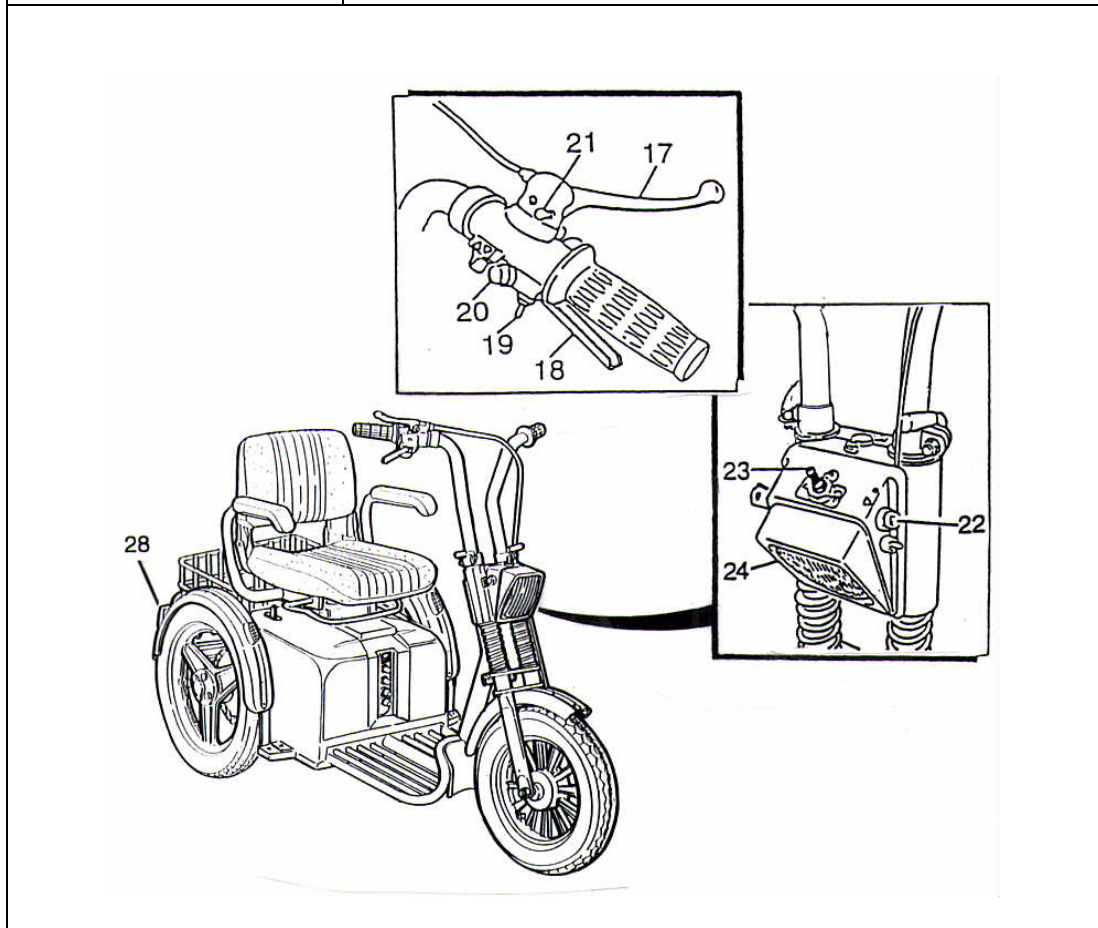

Parking

After stopping, turn the Main Key Switch to OFF and remove the key. The lights will turn OFF. The Electromagnetic Brake is engaged (locked).

Note: The Electromagnetic Brake is automatically locked whenever the Operating Lever is released and after the SPORTSTER stops completely.

The Hand Brake Lever (26) can be locked by pushing Button (27) while squeezing Hand Brake Lever . To release the Hand Brake - squeeze Lever (26) gently.

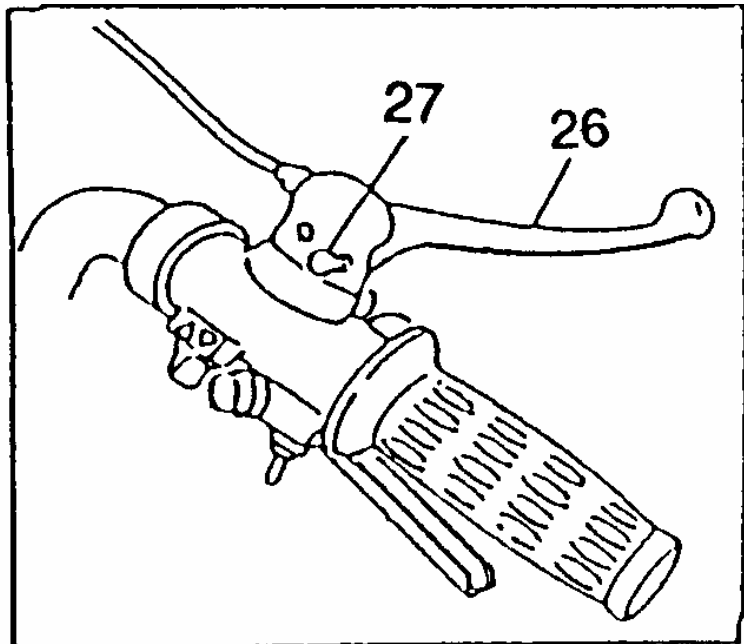

CHAPTER 3 - MAINTENANCE

Note: The numbers in parentheses refer to the parts illustrated in figure 2.

Although the SPORTSTER requires minimal maintenance, do not neglect it. When servicing the SPORTSTER, make sure that it stands on a level surface and that the key is not inserted. In addition, lock the Hand Brake.

Periodic Maintenance Check	No.	Type of Service	Frequency
	1	Check water level in the batteries. Add water as needed. (Lead acid batteries only)	Bimonthly or as per manufacturer's instructions
	2	Check air pressure in all tires.	Every two weeks
Note: To check the batteries, the Gray Cover located under the Seat must be removed.			
Removing the Gray Cover (33) (Single Seat Model)	Remove the Seat (29): hold the backrest at marked position with one hand and press Lever (30) with the other, lifting the seat up off its pivot Release Gray Cover 4 securing screws (31). Lift the Gray Cover until it is released from the Seat Pivot (32).		
Replacing the Gray Cover (33) (Single Seat Model)	The replacement of the Gray Cover is done in reverse order; MAKE SURE that the Gray Cover (33) fits onto it's place. Secure with 4 screws (31).		

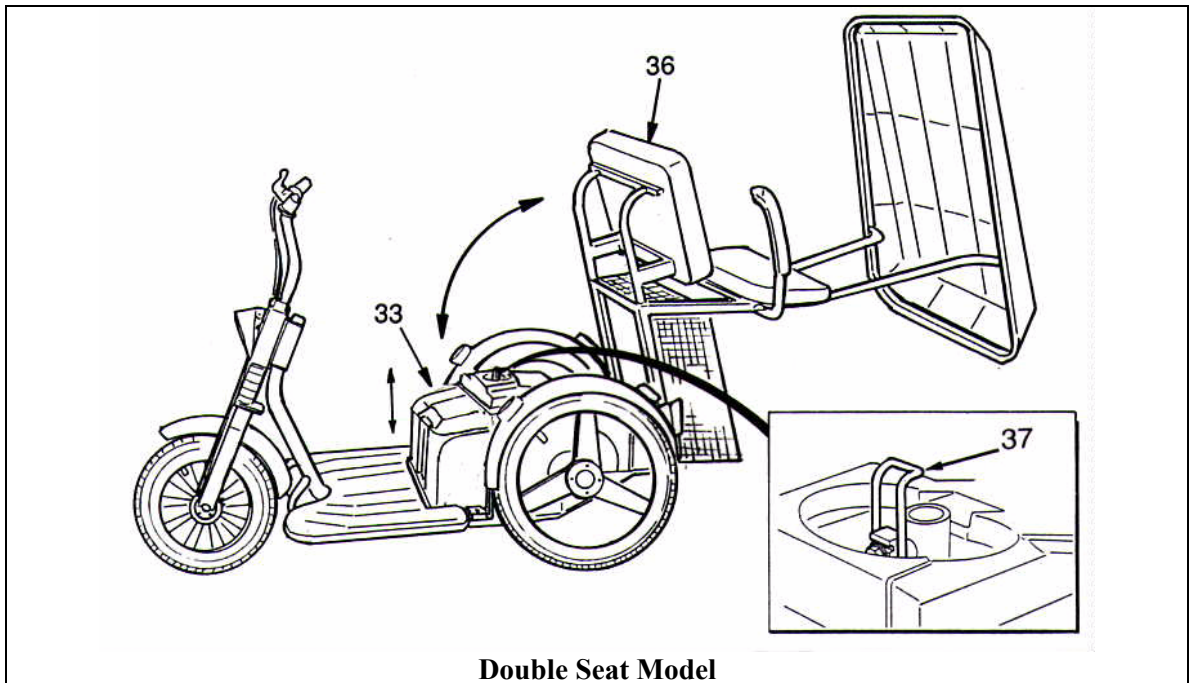
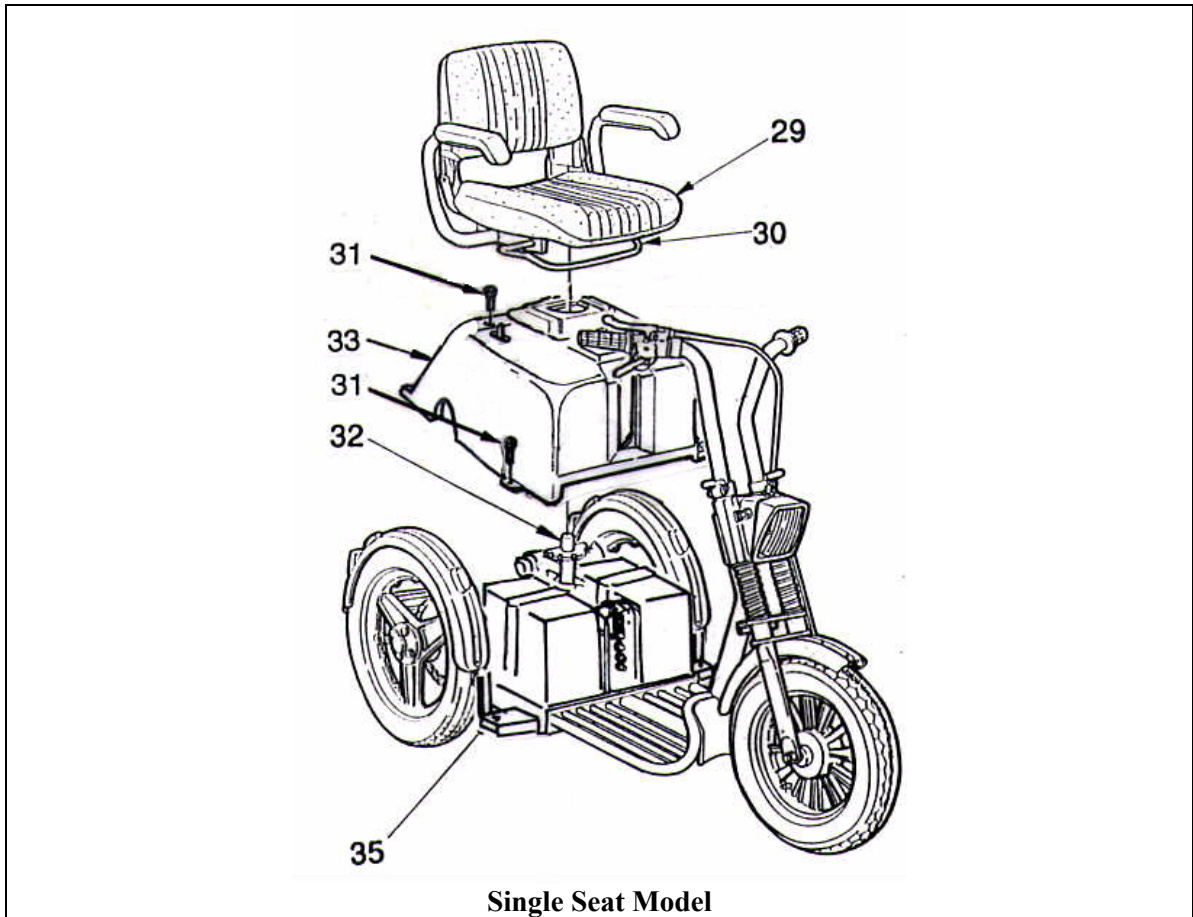

Figure 2. Removing the Gray Cover for Maintenance

Removing the Gray Cover (33) (Double Seat Model)	Release the lock spring (37) under the Seat and tilt Seat (36) back about 70 degrees until it is almost standing on the rear part of the frame. Remove the Gray Cover (33) as described above (for Single Seat Model).
Replacing the Gray Cover (33) (Double Seat Model)	Replacement of the Gray Cover is done in reverse order. Tilt Seat back and mount on Seat Shaft.
Batteries	Every two months, check the water level in both batteries. Note: Failure to maintain water level in the batteries will cause damage and void the manufacturer's warranty.
Checking Water Level	Remove the Gray Cover. Open the strap holding the batteries in place and check the water level in each of the battery cells. Normal water level is approximately 6 mm (1/4") above the plates. If the water level is lower, add distilled water. Note: use ONLY distilled water.
Tires	Correct air pressure in the tires is essential for optimal steering and stability of the SPORTSTER. Check air pressure every two weeks. Inflate to the proper air pressure (20 – 25 psi). Solid tires (optional) should be checked visually and replaced if excessive wear or damage is noticed.

CHAPTER 4 - CHARGING

Read Charger's manual before using the charger..

Warning: If you use a different charger, ask your dealer for instructions.

CHARGING BATTERIES

(See figure 3)

1. Insert the Charging Plug into the Charging Socket located on the front of the GRAY COVER, at the center.
 2. Plug the power cord of the charger into a wall outlet.
 3. When charging is completed and you are ready to go - unplug the charger from the wall outlet and remove the charger plug from the SPORTSTER.
 4. In ideal storage conditions, batteries which were charged to full capacity and were not used should be recharged every 6 months.
 5. If you are planning not to use your SPORTSTER for an extended period of time, we recommend charging it for two days and then disconnecting the batteries.
 6. If you have not used your SPORTSTER for an extended period of time, charge the batteries for at least 24 hours before driving.
- **Note: There is NO need to disconnect the Charging Plug promptly after the charging is complete.**
 - **However, DO NOT leave the Charger connected to the batteries FOR MORE THAN TWO WEEKS.**
 - **As long as the Charging Plug is in the Charger Socket, the electronic control of the SPORTSTER automatically cuts all power to the motor and the SPORTSTER cannot be driven.**

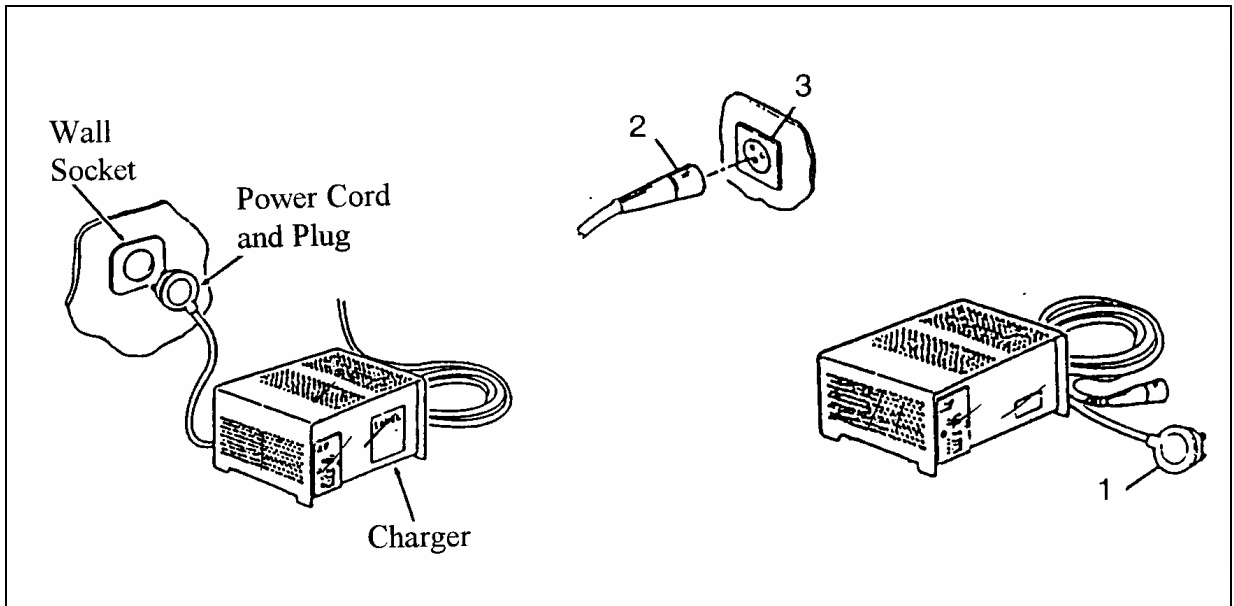

Figure 3. Charging batteries

CHAPTER 5 - TROUBLESHOOTING AND FAULT REPAIR

The following table provides troubleshooting and repair instructions for symptoms encountered when operating the SPORTSTER. It presents the best ways to handle the faults. The table contains three columns:

The Symptom - describes the functional problem that results from the fault.

Probable Cause - lists all probable causes for the relevant symptom. The probable causes are listed logically by order of probability: the first one is the most probable.

Remedy - lists the action to be taken to solve the problem. The appropriate remedy appears opposite each probable cause. These remedies should solve the problem; if not, continue down the list to the next cause/remedy.

Remember: you may contact your dealer at any time for further professional support.

No.	Symptom	Probable Causes	Remedy
1	Flat tire and unstable driving.	<ul style="list-style-type: none"> • Low air pressure. • Puncture. 	<ul style="list-style-type: none"> ◇ Pump to normal pressure. ◇ Repair the punctured tire.
2	The Service LED Flashed and the vehicle does not move.	<ul style="list-style-type: none"> • Manual Release Lever pushed forward. • Controller Coded Fault. 	<ul style="list-style-type: none"> ◇ Pull Lever Backwards. ◇ Ask for technical assistance.
3	The Service LED Flashed and the vehicle moves only at low speed.	<ul style="list-style-type: none"> • Electric column is at up. 	<ul style="list-style-type: none"> ◇ Lower column position.
4	Manual Mechanical Brake Lever is fully pressed but the vehicle does not stop.	<ul style="list-style-type: none"> • Loose hand brake mechanism. 	<ul style="list-style-type: none"> ◇ Tighten the brake cable.
5	The Key Switch is turned to "ON" (clockwise), but the "ON" light does not come on.	<ul style="list-style-type: none"> • Main fuse popped out. 	<ul style="list-style-type: none"> ◇ Reset fuse. <p>Note: Do not reset fuse more than twice. If the symptom recurs after resetting the second time, call the authorized dealer for further technical support.</p>

TROUBLESHOOTING AND FAULT REPAIR (Cont.)

No.	Symptom	Probable Causes	Remedy
6	SPORTSTER does not move when squeezing the Operating Lever .	<ul style="list-style-type: none"> • Main Key Switch is in OFF position. • Charging Plug is installed in Charging Socket. • The Mechanical Release Lever of the Electromagnetic Brake is pushed Forward. • Control system failure. 	<ul style="list-style-type: none"> ◇ Turn the key to “ON” position. ◇ Disconnect the Charging Plug from the SPORTSTER. ◇ Pull out the Lever Backward ◇ Call for technical support.
7	Intermittent drive.	<ul style="list-style-type: none"> • Battery capacity low. • Failed connections • Faulty battery. 	<ul style="list-style-type: none"> ◇ Charge batteries for at least 18 hours. ◇ Remove Gray Cover and check the battery cables connection. In case of corrosion of the terminals, clean the terminals with a damp clean cloth. ◇ If, after recharge, the red lamps are still ON, the battery may be faulty. For replacement, contact your dealer.
8	RIGHT or LEFT turn signal light is inoperative.	<ul style="list-style-type: none"> • Blown light fuse or popped out - Figure 1. • Burnt out bulb. 	<ul style="list-style-type: none"> ◇ Replace light fuse or reset fuse if automatic - see Figure 1. ◇ Replace bulb.
9	Headlight and/or rear light are not lit.	<ul style="list-style-type: none"> • Blown light fuse or popped out - Figure 1. • Burnt out bulb. 	<ul style="list-style-type: none"> ◇ Replace light fuse or reset fuse if automatic - see Figure 1. ◇ Replace Headlight bulb.

CHAPTER 6 - EMI WARNING

All types of electrically powered vehicles, such as powered wheelchairs and motorized scooters (**in this text all types will be referred to as “powered vehicles”**) may be susceptible to electromagnetic interference (EMI). This is interfering **electromagnetic energy (EM)** emitted from sources such as radio and TV stations, amateur radio (HAM) transmitters, two-way radios and cellular phones. The interference (from radio wave sources) can cause the powered vehicle to release its brakes, move by itself, or move in unintended direction. It can also damage the powered vehicle’s control system. The intensity of the interfering EM energy can be measured in volts per meter (V/m). Each powered vehicle can resist EMI up to a certain intensity. This is called its “immunity level”. The higher the immunity level, the greater the protection. At this time, current technology is capable of achieving immunity level, which would provide useful protection from the more common sources of radiated EMI. This vehicle as shipped, with no further modification, has an immunity level of 10 V/m.

There are a number of sources of relatively intense electromagnetic fields in everyday environment. Some of these sources are obvious and easy to avoid. Others are not apparent and exposure is unavoidable. However, we believe that by following the warning listed below, your risk of EMI will be minimized.

The sources of radiated EMI can be broadly classified into three types:

- 1) **Hand-held portable transceivers** (transmitters-receivers) with the antenna mounted directly on the transmitting unit. Examples include: citizen band (CB) radios, “walkie talkies”, security, fire and police transceivers, cellular telephones and other personal communication devices. ** NOTE: some cellular telephones and similar devices transmit signals while they are ON, even when not being used.
- 2) **Medium-range mobile transceivers** (Such as those used in police cars, fire trucks, ambulances and taxis.) These usually have the antenna mounted on the outside of the vehicle, and -
- 3) **Long-range transmitters and transceivers such as commercial broadcast transmitters** (Radio and TV broadcast antenna towers) and amateur (HAM) radios.

NOTE: Other types of hand held devices, such as cordless phones, laptop computers, AM/FM radios, TV sets, CD players, cassette players and small appliances such as electric shavers and hair dryers, as far as we know, are not likely to cause EMI problems to your powered vehicle.

Powered Vehicle Electromagnetic Interference (EMI)

Because EM energy rapidly becomes more intense as one moves closer to the transmitting antenna, the EM field from hand-held radio wave sources (transceivers) are of special concern. It is possible to unintentionally bring high levels of EM energy close to the powered vehicle’s control system while using these devices. This can affect powered vehicle movement and braking. Therefore, the warnings listed below are recommended to prevent possible interference with the control system of the powered vehicle.

WARNINGS

Electromagnetic interference (EMI) from sources such as radio and TV stations, amateur radio (HAM) transmitters, two-way radios and cellular phones can affect powered vehicles.

Following the warnings listed below should reduce the chance of unintended brake release or powered vehicle **movement which could result in serious injury**:

- 1) Do not operate hand-held transceivers (transmitters-receivers) such as citizen band (CB) radios, or turn ON personal communication devices such as cellular phones, while the powered vehicle is ON;
- 2) Be aware of nearby transmitters, such as radio or TV stations and try to avoid coming close to them
- 3) On appearance of unintended movements or brake release occurrences, switch the powered vehicle OFF **as soon as it is safe**.
- 4) Be aware that adding accessories or components, or modifying the powered vehicle, may make it more susceptible to EMI (Note: there is no easy way to evaluate their effect on the overall immunity level of the powered vehicle), and -
- 5) Please report to us all incidents of unintended movement or brake release and note whether there is a source of EMI nearby.

Important information

- 1) 10 volts per meter (V/m) is a generally achievable and useful immunity level against EMI (as of May 1994). The higher the level the greater the protection;
- 2) This product as delivered to you has an immunity level of 10 V/m.

Distributed by



AFIKIM ELECTRIC VEHICLES

KIBBUTZ AFIKIM, 15148, ISRAEL,

Telephones **Main Office:** 972 4 6754814
Sales Department: 972 4 6754180

Fax 972 4 6751456

E - Mail **mainbox@afiscooters.com**

Websites **www.afiscooters.com**