

***Pronto<sup>®</sup> M91<sup>™</sup>  
with SureStep<sup>™</sup>***

***M91 Standard***

***M91 Standard with  
Formula<sup>™</sup> PTO Plus***

***M91 Heavy Duty***

***M91 Heavy Duty with  
Formula PTO Plus***

**DEALER:** This manual **MUST** be given to the user of the wheelchair.

**USER:** **BEFORE** using this wheelchair, read this manual and save for future reference.

For more information regarding  
Invacare products, parts, and services,  
please visit [www.invacare.com](http://www.invacare.com)



**Yes, you can:**

---

---

## **⚠ WARNING**

**A QUALIFIED TECHNICIAN MUST PERFORM THE INITIAL SET UP OF THIS WHEELCHAIR. ALSO, A QUALIFIED TECHNICIAN MUST PERFORM ALL PROCEDURES IN THE SERVICE MANUAL.**

**WHEELCHAIR USERS: DO NOT SERVICE OR OPERATE THIS EQUIPMENT WITHOUT FIRST READING AND UNDERSTANDING (1) THE OWNER'S OPERATOR AND MAINTENANCE MANUAL AND (2) THE SEATING SYSTEM'S MANUAL (IF APPLICABLE). IF YOU ARE UNABLE TO UNDERSTAND THE WARNINGS, CAUTIONS, AND INSTRUCTIONS, CONTACT INVACARE TECHNICAL SUPPORT BEFORE ATTEMPTING TO SERVICE OR OPERATE THIS EQUIPMENT - OTHERWISE INJURY OR DAMAGE MAY RESULT.**

**DEALERS AND QUALIFIED TECHNICIANS: DO NOT SERVICE OR OPERATE THIS EQUIPMENT WITHOUT FIRST READING AND UNDERSTANDING (1) THE OWNER'S OPERATOR AND MAINTENANCE MANUAL, (2) THE SERVICE MANUAL (IF APPLICABLE) AND (3) THE SEATING SYSTEM'S MANUAL (IF APPLICABLE). IF YOU ARE UNABLE TO UNDERSTAND THE WARNINGS, CAUTIONS AND INSTRUCTIONS, CONTACT INVACARE TECHNICAL SUPPORT BEFORE ATTEMPTING TO SERVICE OR OPERATE THIS EQUIPMENT - OTHERWISE, INJURY OR DAMAGE MAY RESULT.**

---

*NOTE: Updated versions of this manual are available on [www.invacare.com](http://www.invacare.com).*

# TABLE OF CONTENTS

<b>SPECIAL NOTES .....</b>	<b>11</b>
<b>LABEL LOCATIONS .....</b>	<b>13</b>
M91 Standard.....	13
M91 Heavy Duty.....	14
M91 with Formula PTO Plus Seating System.....	15
Wheelchairs With TRRO.....	16
Wheelchairs Without TRRO.....	16
<b>TYPICAL PRODUCT PARAMETERS .....</b>	<b>17</b>
PRONTO M91 .....	17
Formula PTO Plus .....	18
<b>SECTION 1—GENERAL GUIDELINES .....</b>	<b>19</b>
Controller Settings/Repair or Service .....	19
Operation Information.....	19
Wheelchairs with Powered Seating Systems Only.....	21
Accessories .....	21
Batteries.....	22
Charging Batteries .....	22
Grounding Instructions .....	23
Rain Test.....	24
Weight Training.....	24
Weight Limitation.....	24
<b>SECTION 2—EMI INFORMATION .....</b>	<b>25</b>
<b>SECTION 3—SAFETY/HANDLING OF WHEELCHAIRS .....</b>	<b>27</b>
Stability and Balance.....	27
Coping With Everyday Obstacles.....	28
A Note to Wheelchair Assistants .....	28
Lifting/Stairways .....	29
Transferring To and From Other Seats .....	30
Percentage of Weight Distribution .....	31
Reaching, Leaning and Bending - Forward.....	31
Reaching and Bending - Backward.....	32
<b>SECTION 4—SAFETY INSPECTION/TROUBLESHOOTING .....</b>	<b>33</b>

# TABLE OF CONTENTS

Safety Inspection Checklists.....	33
All Wheelchairs .....	33
Inspect/Adjust Initially.....	33
Inspect/Adjust Weekly .....	34
Inspect/Adjust Monthly .....	34
Inspect/Adjust Periodically .....	34
Additional Requirements for Wheelchairs with Formula PTO Plus Systems.....	35
Inspect/Adjust Initially.....	35
Inspect/Adjust Weekly .....	35
Inspect/Adjust Monthly .....	35
Inspect/Adjust Periodically .....	35
Troubleshooting Guide .....	36
All Wheelchairs .....	36
Wheelchairs with Formula PTO Plus Systems.....	37
Checking Battery Charge Level.....	37
<b>SECTION 5—WHEELCHAIR OPERATION .....</b>	<b>38</b>
Operating the Wheelchair.....	38
Turning the Power On/Off.....	38
Using the Joystick to Drive the Wheelchair.....	39
Operating the Formula PTO Plus System.....	40
Increasing the Tilt Angle.....	41
Decreasing the Tilt Angle.....	41
SPJ-80 Joystick Switches and Indicators .....	42
On/Off Toggle Switch .....	43
Speed Control Knob .....	43
Joystick.....	43
Battery Gauge Display .....	43
Charger/Programming Input.....	43
DPJ Joystick Switches and Indicators .....	44
Drive Select Toggle Switch.....	44
Selecting the Drive Mode .....	44
Speed Control knob.....	44
Joystick.....	44
Mode (On/Off) Switch .....	45
Battery Gauge Display (BGD).....	45

# TABLE OF CONTENTS

MPJ Joystick Switches and Indicators .....	45
Drive Select Toggle Switch .....	46
Selecting the Drive Mode .....	46
Speed Control .....	46
Joystick.....	46
LCD Display .....	46
Emergency Stop/Reset Switch.....	47
Emergency Stop/Reset Input .....	48
Remote On/Off Switch.....	48
SPJ+ Joystick Switches and Indicators.....	48
On/Off Button .....	48
Speedometer.....	49
Speed Control Buttons.....	49
Joystick.....	49
Charger/Programming Input.....	49
Service Indicator.....	49
Information Gauge Display .....	50
<b>SECTION 6—ARMS .....</b>	<b>52</b>
Installing/Removing Flip Back Armrests .....	52
Installing.....	52
Removing .....	53
Adjusting Flip Back Armrests.....	53
Positioning Flip Back Armrests for User Transfer .....	53
Positioning Flip Back Armrests for Use.....	53
Adjusting .....	54
Adjusting Van Seat Armrests .....	54
Angle .....	54
Height .....	54
<b>SECTION 7—SEAT .....</b>	<b>55</b>
Adjusting the Headrest .....	55
Adjusting the Back Angle .....	55
Van Seat Model.....	55
Adjustable Seat Back Angle (ASBA) Model.....	55
Removing/Installing the Seat Assembly.....	56
Removing .....	56
Installing.....	57
Adjusting the Seat Height .....	57
Adjusting Seat Position on Seat Frame.....	59
Adjustable ASBA And Formula PTO Plus Models .....	59
Van Seat Model.....	59

# TABLE OF CONTENTS

Adjusting Seat Depth - Van Seat Only.....	60
Replacing the Seat Positioning Strap .....	61
Wheelchairs with TRRO Option .....	61
Wheelchairs without TRRO Option.....	61
Adjustable ASBA and Formula PTO Plus Models .....	61
Van Seat Model .....	62
Tilting the Seat Assembly.....	63
Tilting the Seat Assembly Back.....	63
Tilting the Seat Assembly Forward.....	64
<b>SECTION 8—FOOTBOARD ASSEMBLY .....</b>	<b>65</b>
Removing/Installing the Footboard Assembly.....	65
Removing .....	65
Installing.....	65
Adjusting the Footboard Assembly .....	66
Angle .....	66
Depth .....	67
<b>SECTION 9—FRONT RIGGINGS .....</b>	<b>68</b>
Installing/Removing Front Riggings .....	68
Installing.....	68
Removing .....	68
Adjusting Footrest Height .....	69
Model PHWH93 .....	69
Model PH904A and PHAL4A.....	69
Replacing Heel Loops .....	70
Raising/Lowering Elevating Front Riggings.....	70
Adjusting/Replacing Telescoping Front Rigging Supports - Van Style Seats.....	71
Adjusting/Replacing Telescoping Front Rigging Support .....	72
Removing/Installing the Center Mount Footrest .....	73
Removing .....	73
Installing.....	73
Adjusting the Height of the Center Mount Footrest.....	74
Adjusting the Angle of the Center Mount Footrest.....	75
Adjusting the Footplate Angle .....	75
Adjusting the Tension of the Flip Up Footplate.....	76
<b>SECTION 10—SHROUD/WHEELS .....</b>	<b>77</b>

# TABLE OF CONTENTS

Replacing the Flat Free Tires on the Wheel Rim.....	77
Removing/Installing the Shrouds .....	77
Removing .....	77
Installing.....	78
Engaging/Disengaging Motor Release Lever .....	79
Replacing Front/Rear Caster Assemblies.....	80
Adjusting Forks .....	80
<b>SECTION I I—BATTERIES .....</b>	<b>8 I</b>
Installing/Removing the Batteries.....	82
Installing.....	82
Removing .....	84
Connecting/Disconnecting the Battery Wiring Harness.....	85
Connecting .....	85
Disconnecting .....	86
Charging Batteries.....	87
Battery Charger Operation.....	88
On-Board Battery Charger.....	88
Independent Charger .....	89
<b>SECTION I 2—ELECTRONICS .....</b>	<b>9 I</b>
Repositioning the Joystick.....	91
Adjustable Seat Back Angle (ASBA) Model.....	91
Van Seat Model.....	92
Disconnecting/Connecting the MK5 Joysticks.....	93
Disconnecting .....	93
Connecting .....	93
Programming the Control Module.....	94
<b>SECTION I 3—TRANSPORT READY PACKAGE .....</b>	<b>95</b>
About Transport Ready Packages.....	96
Compliance Information .....	96
Specifications.....	96
Securing the Wheelchair to the Vehicle .....	97
Positioning the Wheelchair in the Vehicle.....	97
Securement Points.....	98
Securing the Wheelchair .....	98

---

Securing the Occupant.....	99
Wheelchair-Anchored Belts.....	99
Vehicle-Anchored Belts.....	100
Seating System.....	100
Positioning Belts.....	101
<b>LIMITED WARRANTY .....</b>	<b>104</b>

## **REGISTER YOUR PRODUCT**

The benefits of registering:

1. Safeguard your investment.
2. Ensure long term maintenance and servicing of your purchase.
3. Receive updates with product information, maintenance tips, and industry news.
4. Invacare can contact you or your provider, if servicing is needed on your product.
5. It will enable Invacare to improve product designs based on your input and needs.

**Register ONLINE at [www.invacare.com](http://www.invacare.com)**

**- or -**

**Complete and mail the form on the next page**

Any registration information you submit will be used by Invacare Corporation only, and protected as required by applicable laws and regulations.





# PRODUCT REGISTRATION FORM

Register **ONLINE** at [www.invacare.com](http://www.invacare.com) - or -  
Complete and mail this form

Name \_\_\_\_\_

Address \_\_\_\_\_

City \_\_\_\_\_ State/Province \_\_\_\_\_

Zip/Postal Code \_\_\_\_\_

Email \_\_\_\_\_ Phone No. \_\_\_\_\_

Fold  
here

Invacare Model No. \_\_\_\_\_ Serial No. \_\_\_\_\_

Purchased From \_\_\_\_\_ Date of Purchase: \_\_\_\_\_

1. Method of purchase: (check all that apply)

Medicare  Insurance  Medicaid  Other \_\_\_\_\_

2. This product was purchased for use by: (check one)

Self  Parent  Spouse  Other

3. Product was purchased for use at:

Home  Facility  Other

4. I purchased an Invacare product because:

Price  Features (list features) \_\_\_\_\_

5. Who referred you to Invacare products? (check all that apply)

Doctor  Therapist  Friend  Relative  Dealer/Provider  Other \_\_\_\_\_

Advertisement (circle one): TV, Radio, Magazine, Newspaper  No Referral \_\_\_\_\_

6. What additional features, if any, would you like to see on this product?

\_\_\_\_\_ Fold  
here

7. Would you like information sent to you about Invacare products that may be available for a particular medical condition?  Yes  No

If yes, please list any condition(s) here and we will send you information by email and/or mail about any available Invacare products that may help treat, care for or manage such condition(s):

\_\_\_\_\_

8. Would you like to receive updated information via email or regular mail about the Invacare home medical products sold by Invacare's dealers?  Yes  No

9. What would you like to see on the Invacare website?

\_\_\_\_\_

10. Would you like to be part of future online surveys for Invacare products?  Yes  No

11. User's Year of birth: \_\_\_\_\_

If at any time you wish not to receive future mailings from us, please contact us at Invacare Corporation, CRM Department, 39400 Taylor Parkway, Elyria, OH 44035, or fax to 877-619-7996 and we will remove you from our mailing list.

To find more information about our products, visit [www.invacare.com](http://www.invacare.com).

Cut Along Line



Fold  
here

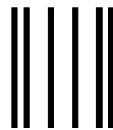

**BUSINESS REPLY MAIL**  
FIRST-CLASS MAIL PERMIT NO. 196 ELYRIA OH

POSTAGE WILL BE PAID BY ADDRESSEE

INVACARE CORPORATION  
CRM DEPARTMENT  
39400 TAYLOR PARKWAY  
ELYRIA OH 44035-9836

NO POSTAGE  
NECESSARY  
IF MAILED  
IN THE  
UNITED STATES

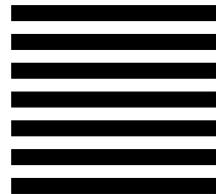

Cut Along Line

Fold  
here



Invacare Product Registration Form

Please Seal with  
Tape Before Mailing



## SPECIAL NOTES

Signal words are used in this manual and apply to hazards or unsafe practices which could result in personal injury or property damage. Refer to the table below for definitions of the signal words.

SIGNAL WORD	MEANING
DANGER	Danger indicates an imminently hazardous situation which, if not avoided, will result in death or serious injury.
WARNING	Warning indicates a potentially hazardous situation which, if not avoided, could result in death or serious injury.
CAUTION	Caution indicates a potentially hazardous situation which, if not avoided, may result in property damage.

### NOTICE

**THE INFORMATION CONTAINED IN THIS DOCUMENT IS SUBJECT TO CHANGE WITHOUT NOTICE.**

#### WHEELCHAIR USER

As a manufacturer of wheelchairs, Invacare endeavors to supply a wide variety of wheelchairs to meet many needs of the end user. However, final selection of the type of wheelchair to be used by an individual rests solely with the user and his/her healthcare professional capable of making such a selection.

#### WHEELCHAIR TIE-DOWN RESTRAINTS AND SEAT RESTRAINTS (TRRO AND TRBKTS)

TRRO includes four factory-installed transport brackets and a wheelchair anchored pelvic belt. TRRO has been crash-tested in accordance with ANSI/RESNA WC Vol I Section 19 Frontal Impact Test requirements for wheelchairs with a 168 lb crash dummy, which corresponds to a person with a weight of 114 to 209 lbs.

TRBKTS includes four factory-installed wheelchair transport brackets. TRBKTS has not been crash-tested in accordance with WC 19. Invacare recommends that these transport brackets be used only to secure an unoccupied wheelchair during transport.

As of this date, the Department of Transportation has not approved any tie-down systems for transportation of a user while in a wheelchair, in a moving vehicle of any type. It is Invacare's position that users of wheelchairs should be transferred into appropriate seating in vehicles for transportation and use be made of the restraints made available by the auto industry. Invacare cannot and does not recommend any wheelchair transportation systems.

Refer to [About Transport Ready Packages](#) on page 96 for more information about transporting the wheelchair.

### **TRRO AND TRBKTS WARNING**

Only use the transport brackets included with TRRO and TRBKTS for the purposes described in this manual.

## **⚠ WARNINGS**

Invacare products are specifically designed and manufactured for use in conjunction with Invacare accessories. Accessories designed by other manufacturers have not been tested by Invacare and are not recommended for use with Invacare products.

The seat positioning strap is a positioning belt only. It is not designed for use as a safety device withstanding high stress loads such as auto or aircraft safety belts. If signs of wear appear, belt must be replaced immediately.

**POWERED SEATING SYSTEMS ONLY** - This seating system has been custom designed and will be assembled to the wheelchair base before delivery to the user. The information contained in this manual is for maintaining and adjusting the seating system. There are very few adjustments that can safely be made by the user. If there is a procedure or adjustment that needs to be performed on the seating system that is not in this manual, do not perform that procedure. Have the seating system serviced by a qualified technician.

The drive behavior initially experienced by the user may be different from other chairs previously used. This Power Wheelchair has Invacare's SureStep technology, a feature that provides the wheelchair with optimum traction and stability when driving forward over transitions and thresholds of up to 3-inches. The following warnings apply specifically to the SureStep Feature.

- **DO NOT** use on inclines greater than 9°.
- **DO NOT** use on inclines with wet, slippery, icy or oily surfaces. This may include certain painted or otherwise treated wood surfaces.
- **DO NOT** traverse down ramps at high speed. Doing so will reduce traction and increase stopping distance.
- The end user's weight can materially affect traction on sloped surfaces. Great care should be taken when traversing such slopes.

To determine and establish your particular safety limits, practice use of this product on various sloping surfaces in the presence of a qualified healthcare provider **BEFORE** attempting active use of this wheelchair. Other general warnings listed within this document also apply.

Wheelchairs should be examined during maintenance for signs of corrosion (water exposure, incontinence, etc.). Electrical components damaged by corrosion should be replaced **IMMEDIATELY**.

Wheelchairs that are used by incontinent users and/or are frequently exposed to water may require replacement of electrical components more frequently.

---

# LABEL LOCATIONS

## M91 Standard

**WEIGHT CAPACITY**  
**LIMITE DE POIDS**  
**300 LBS. (136 kgs.)**  
 REFER TO OWNER'S MANUAL  
 SE RÉFÉRER AU MANUEL DE L'UTILISATEUR

P/N 1111028

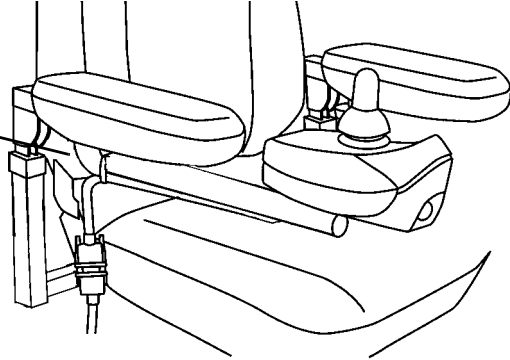

**WARNING**  
 WIRING DIAGRAM for Dual 22NF Batteries  
**DO NOT REMOVE THIS LABEL**

The POSITIVE (+) RED Battery Cable MUST connect to the POSITIVE (+) Battery Terminal(s)/ Post(s). The NEGATIVE (-) BLACK Battery Cable MUST connect to the NEGATIVE (-) Battery Terminal(s)/Post(s). DO NOT allow Battery Cable(s) to contact the opposite Battery Terminal(s)/Post(s). Install protective caps on POSITIVE (+) and NEGATIVE (-) battery terminals. Replace cable(s) immediately if cable(s) insulation becomes damaged. Failure to observe these warnings may result in an electrical short with serious personal injury and/or damage to the electrical system. See Owner's Manual.

DO NOT remove fuse or mounting hardware from POSITIVE (+) RED battery cable mounting screw. P/N 1114804

**AVERTISSEMENT**  
 SCHEMA POUR LE FILAGE des batteries doubles 22NF  
**NE PAS ENLEVER CETTE ÉTIQUETTE**

Le câble ROUGE POSITIF (+) DOIT être connecté à la borne POSITIVE(+). Le câble NOIR NEGATIF (-) DOIT être connecté à la borne NEGATIVE (-). NE PAS laisser les câbles de batteries toucher les bornes opposées. Remplacer le câble immédiatement si l'isolation du câble est endommagée. Un court-circuit peut se produire et causer des blessures graves et/ou des dommages au système électrique si ces avertissements ne sont pas respectés. Se référer au MANUEL DE L'UTILISATEUR.

NE PAS enlever le fusible ou la quincaillerie de montage de la vis de montage du câble de batterie ROUGE POSITIF(+).

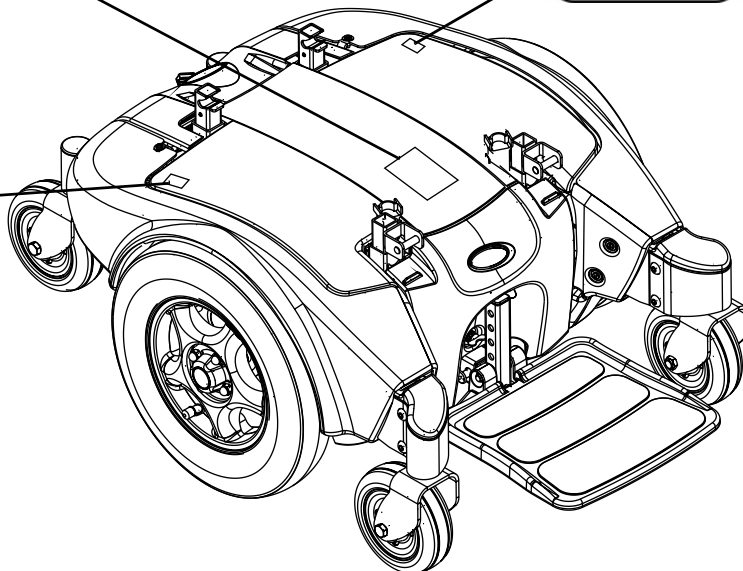

# M9I Heavy Duty

**WEIGHT CAPACITY**  
**LIMITE DE POIDS**  
**400 LBS. (182 kgs.)**  
 REFER TO OWNER'S MANUAL  
 SE RÉFÉRER AU MANUEL DE L'UTILISATEUR

P/N 1111030

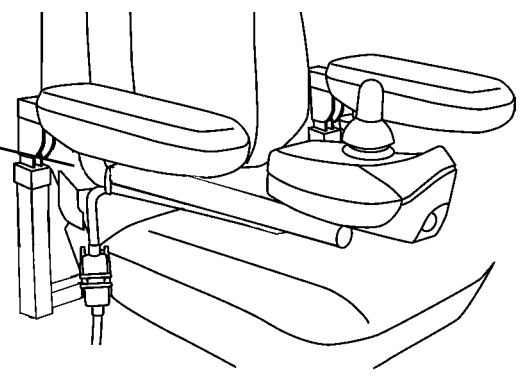

**⚠ WARNING**

WIRING DIAGRAM for Dual 22NF Batteries  
DO NOT REMOVE THIS LABEL

The POSITIVE (+) RED Battery Cable MUST connect to the POSITIVE (+) Battery Terminal(s)/Post(s). The NEGATIVE (-) BLACK Battery Cable MUST connect to the NEGATIVE (-) Battery Terminal(s)/Post(s). DO NOT allow Battery Cable(s) to contact the opposite Battery Terminal(s)/Post(s). Install protective caps on POSITIVE (+) and NEGATIVE (-) battery terminals. Replace cable(s) immediately if cable(s) insulation becomes damaged. Failure to observe these warnings may result in an electrical short with serious personal injury and/or damage to the electrical system. See Owner's Manual.

DO NOT remove fuse or mounting hardware from POSITIVE (+) RED battery cable mounting screw. P/N 1118397

**⚠ AVERTISSEMENT**

SCHEMA POUR LE FILAGE des batteries doubles 22NF  
NE PAS ENLEVER CETTE ÉTIQUETTE

Le câble ROUGE POSITIF (+) DOIT être connecté à la borne POSITIVE(+). Le câble NOIR NEGATIF (-) DOIT être connecté à la borne NEGATIVE (-). NE PAS laisser les câbles de batteries toucher les bornes opposées. Remplacer le câble immédiatement si l'isolation du câble est endommagée. Un court-circuit peut se produire et causer des blessures graves et/ou des dommages au système électrique si ces avertissements ne sont pas respectés. Se référer au MANUEL DE L'UTILISATEUR.

NE PAS enlever le fusible ou la quincaillerie de montage de la vis de montage du câble de batterie ROUGE POSITIF(+).

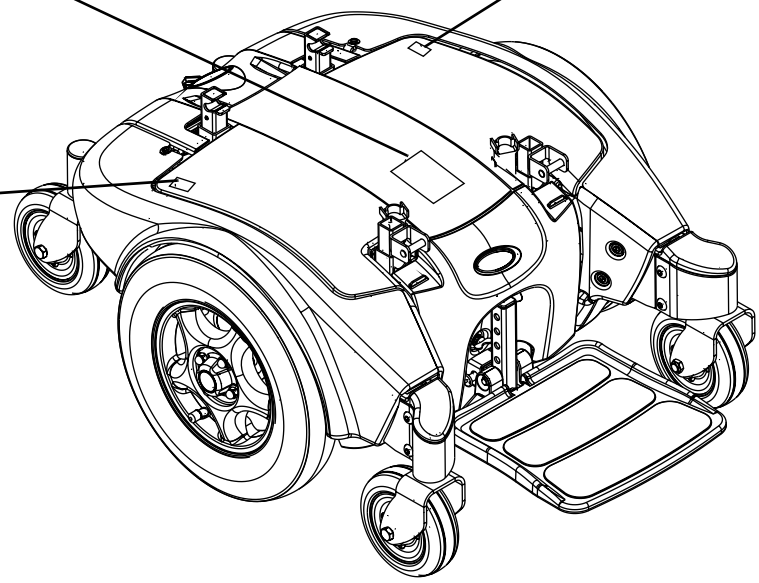

# M9I with Formula PTO Plus Seating System

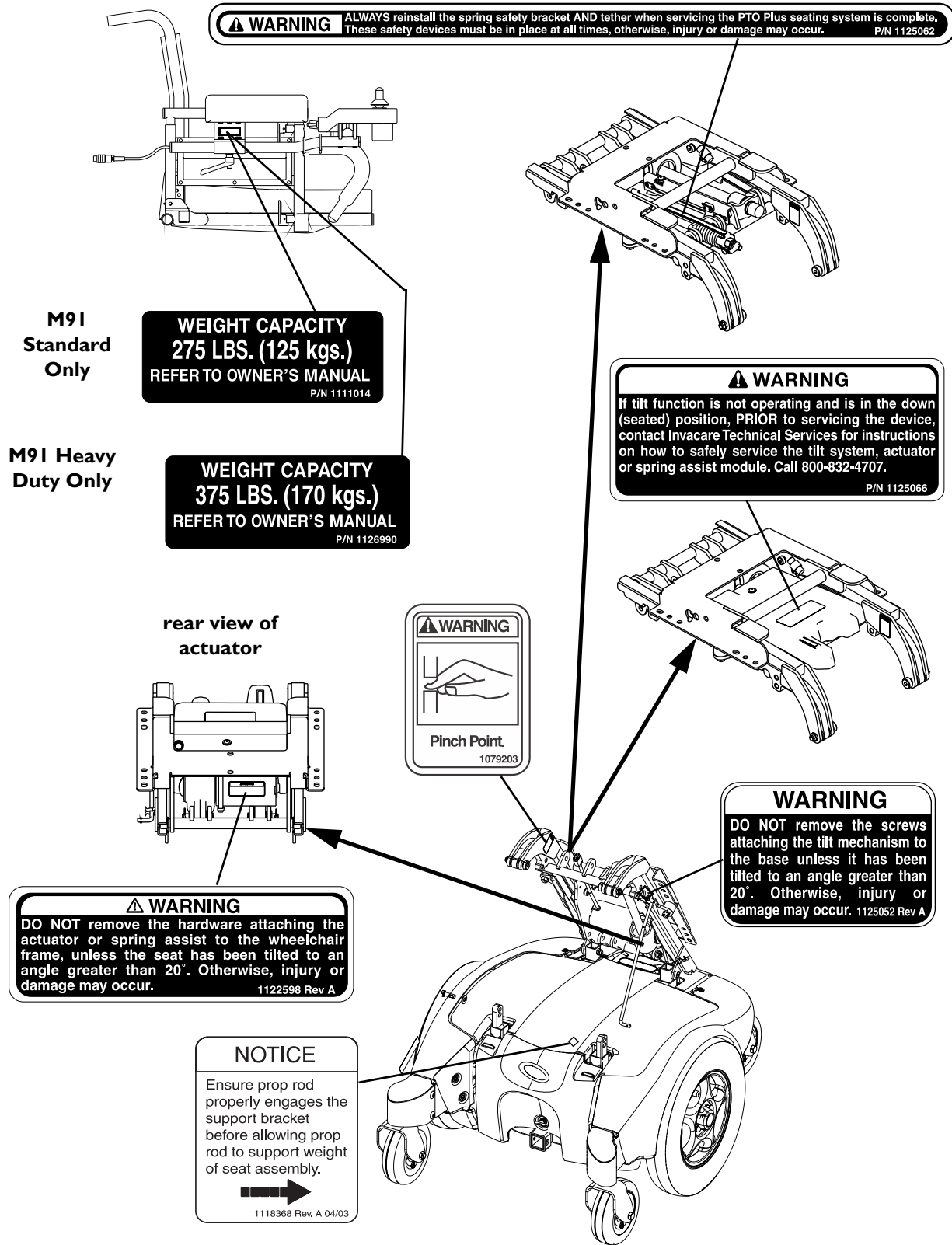

# Wheelchairs With TRRO

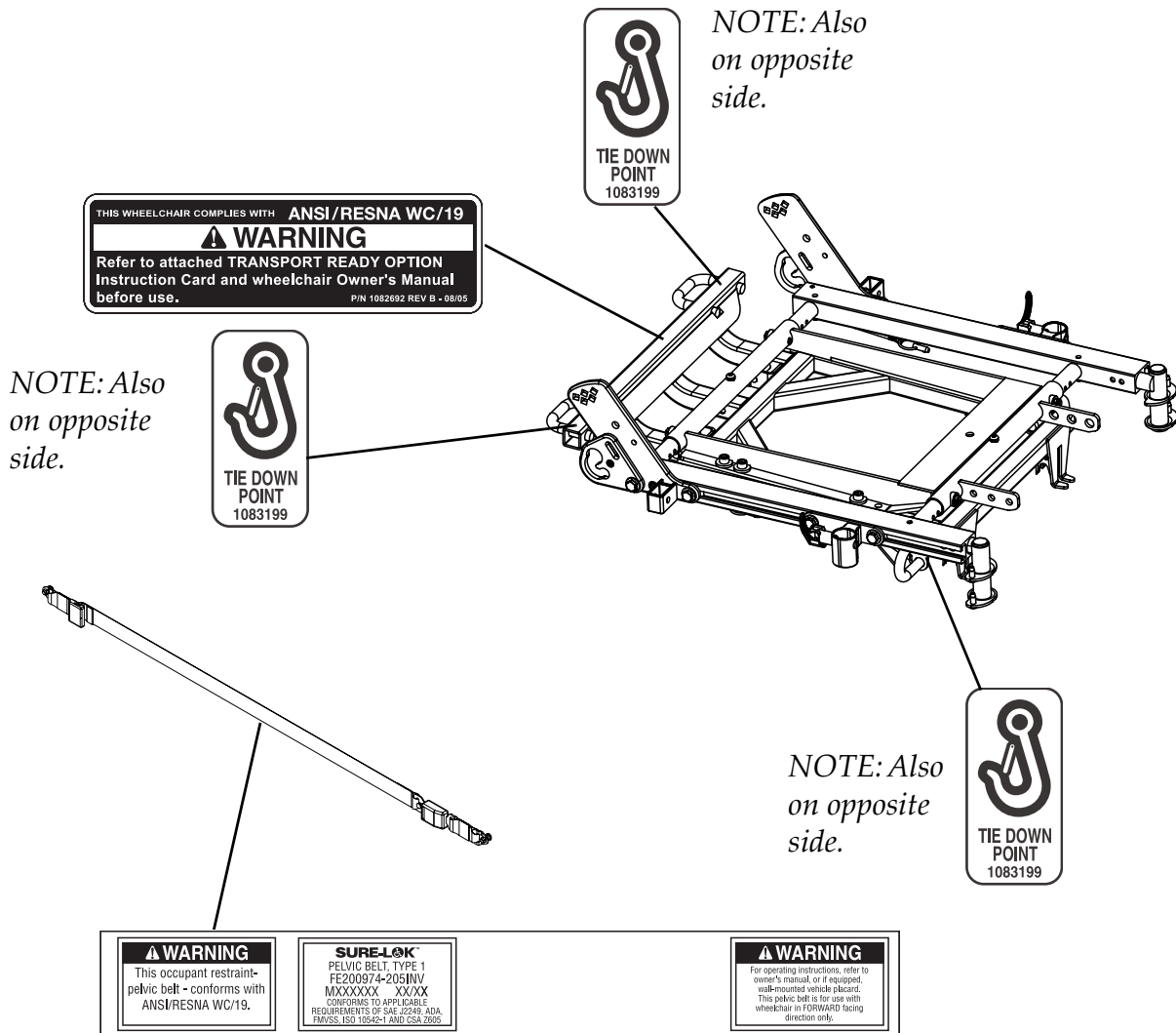

# Wheelchairs Without TRRO

*NOTE: Auto style seat positioning strap shown. This label is also on the airline style seat positioning strap.*

**WARNING**  
 This seat/chest positioning strap is **NOT** intended for occupant restraint in a moving motor vehicle, and **DOES NOT** conform with ANSI/RESNA WC/19. If signs of wear appear, positioning strap **MUST** be replaced **IMMEDIATELY**.

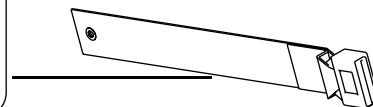



# TYPICAL PRODUCT PARAMETERS

## PRONTO M91

	18-INCH VAN SEAT	20-INCH VAN SEAT	22-INCH VAN SEAT	ADJUSTABLE ASBA SEAT
<b>SEAT WIDTH RANGE:</b>	18 inches	20 inches	22 inches	16-24 inches
<b>SEAT DEPTH:</b>	16 -18 inches	18-20 inches	20-22 inches	16-20 inches
<b>BACK HEIGHT W/O HEADREST SEMI RECLINE:</b>	18 inches	18 inches	18 inches	16-20 inches
<b>BACK ANGLE RANGE SEMI RECLINE:</b>	35° to 115°	35° to 115°	35° to 115°	Standard - 85° to 105°
<b>UPHOLSTERY:</b>	Grey Vinyl, Grey Cloth, Tan Vinyl			Black Nylon Back
<b>SEAT-TO-FLOOR:</b>	22½ to 23½ inches (Cushion Not Compressed)			20-22 inches (To Seat Pan)
<b>OVERALL WIDTH (NO JOYSTICK):</b>	25-7/8 inches			
<b>OVERALL HEIGHT:</b>	36-49¼ inches (Semi Recline Back)			
<b>OVERALL LENGTH:</b>	39 inches (With Footboard Folded)			
<b>DRIVE WHEELS/TIRES:</b>	14 x 3-inch			
<b>CASTERS:</b>	6 x 2-inch Front/Rear with Precision Sealed Bearings			
<b>FOOTRESTS/LEGRESTS:</b>	Flip Up, Depth and Height Adjustable, Footboard, Swingaway Front Rigging, Elevating Legrest			
<b>WEIGHT W/SEATING SYSTEM AND ACCESSORIES</b>				
W/O BATTERIES:	199 lbs			
W/BATTERIES:	273 lbs			
<b>SHIPPING:</b>	260 lbs (w/o Batteries), 310 lbs (w/Batteries)			
<b>ARMRESTS:</b>	Adjustable Angle, Depth and Width			
<b>BATTERIES:</b>	22NF - Quantity 2			
<b>INCLINE CAPABILITY:</b>	9°			
<b>PERFORMANCE</b>				
<b>SPEED</b>				
Standard:	0 to 6.4 mph			
Heavy Duty:	0 to 4.25 mph			
<b>TURNING RADIUS:</b>	19½ inches (Front with Footboard); 21½ inches (Rear)			
<b>*RANGE (VARIABLE)</b>				
Standard:	22 miles			
Heavy Duty:	12-16 miles			
<b>**WEIGHT LIMITATION</b>				
Standard:	300 lbs			
Heavy Duty:	400 lbs			

NOTE: Based on 18-inch deep Van seat.

## TYPICAL PRODUCT PARAMETERS

\*NOTE: Values for range are calculated for maximum chair weight rating using largest batteries applicable (22NF), per test procedures described in ANSI/RESNA WC/VOL2-1998 Section 4 and meet federal reimbursement requirements for this product. While considered typical, they are derived based on certain ideal conditions. Variances in battery condition, user weight, usage pattern or overall terrain conditions will result in actual values for range that differ from these stated values. Users should become accustomed to how their unique conditions impact their individual results. Users should become familiar with the battery discharge indicator on the joystick to determine the range of their wheelchair. Refer to Battery Charger Operation on page 88 for more information about the battery discharge indicator.

\*\*NOTE: Refer to Percentage of Weight Distribution on page 31.

## Formula PTO Plus

<b>SEAT WIDTH RANGE:</b>	16 - 22 inches
<b>SEAT DEPTH RANGE (1-INCH INCREMENTS):</b>	16 - 22 inches
<b>BACK HEIGHT RANGE:</b>	16 - 24 inches
<b>BACK ANGLE RANGE (ADJUSTABLE ASBA):</b>	85° to 105° in 5° increments
<b>*SEAT-TO-FLOOR HEIGHT (ADJUSTABLE):</b>	18 - 20 inches ± ½ inch increments
<b>OVERALL WIDTH</b> WITHOUT JOYSTICK: WITH JOYSTICK AND TRSS:	26 inches 27 inches
<b>OVERALL HEIGHT:</b>	37 - 45 inches
<b>OVERALL LENGTH WITH FRONT RIGGINGS:</b>	44 inches
<b>TILT RANGE</b> 0° SEAT PAN ANGLE: 5° SEAT PAN ANGLE:	0 - 55° 5 - 60°
<b>TURNING RADIUS WITH FRONT RIGGINGS:</b>	27½ inches
<b>SEAT CUSHION:</b>	Cushion (Optional)
<b>WEIGHT OF FORMULA PTO PLUS:</b>	25 lbs
<b>ARMRESTS:</b>	Adjustable Angle, Height and Depth
<b>WEIGHT LIMITATION OF M9I WITH FORMULA PTO PLUS</b> M9I STANDARD: M9I HEAVY DUTY OPTION:	Up to 275 lbs Up to 375 lbs

\*NOTE: The seat-to-floor heights are based on 18-inch deep seat with 0° (±1°) seat pan angle and pneumatic tires or flat free inserts. Seat-to-floor height measured from the front edge of seat to floor. All heights are measured with properly inflated new tires. These heights can vary ±¼-inch due to tire wear.

### **⚠ WARNING**

If the seating system is mounted onto a power wheelchair that has a weight limitation greater than that of the seating system, the weight limitation is maintained at the seating system's weight limitation. Example: The M9I Standard wheelchair has a 300 lb weight limitation, the seating system has a weight limitation of 275 lbs, so the M9I Standard wheelchair now has a 275lb. weight limitation.

---

# SECTION I—GENERAL GUIDELINES

---

## **⚠ WARNING**

**SECTION I - GENERAL GUIDELINES** contains important information for the safe operation and use of this product. **DO NOT** use this product or any available optional equipment without first completely reading and understanding these instructions and any additional instructional material such as **Owner's Manuals, Service Manuals or Instruction Sheets** supplied with this product or optional equipment. If you are unable to understand the **Warnings, Cautions or Instructions**, contact a healthcare professional, dealer or technical personnel before attempting to use this equipment - otherwise, injury or damage may occur.

---

## **Controller Settings/Repair or Service**

Set-up of the Electronics Control Unit is to be performed only by a qualified technician. The final adjustments of the controller may affect other activities of the wheelchair. Damage to the equipment could occur if improperly set-up or adjusted.

DO NOT service or adjust your wheelchair while occupied, unless otherwise noted.

If tilt function is not operating and is in the down (seated) position, PRIOR to servicing the device, contact Invacare Technical Services for instructions on how to safely service the tilt system, actuator or spring assist module. Call 800-832-4707.

ALWAYS reinstall the spring safety bracket AND tether when servicing the PTO Plus seating system is complete. These safety devices MUST be in place at all times, otherwise, injury or damage may occur.

**TRANSPORT READY PACKAGES ARE NOT RETROFITTABLE TO EXISTING MODELS AND ARE NOT FIELD SERVICEABLE.**

## **Operation Information**

Performance adjustments should only be made by professionals of the healthcare field or persons fully conversant with this process and the driver's capabilities. Incorrect settings could cause injury to the driver, bystanders, damage to the wheelchair and to surrounding property.

After the wheelchair has been set-up, check to make sure that the wheelchair performs to the specifications entered during the set-up procedure. If the wheelchair does NOT perform to specifications, turn the wheelchair OFF immediately and reenter set-up specifications. Repeat this procedure until the wheelchair performs to specifications.

ALWAYS shift your weight in the direction you are turning. DO NOT shift your weight in the opposite direction of the turn. Shifting your weight in the opposite direction of the turn may cause the inside drive wheel to lose traction and the wheelchair to tip over.

DO NOT shift your weight or sitting position toward the direction you are reaching as the wheelchair may tip over.

DO determine and establish your particular safety limits by practicing bending, reaching and transferring activities in the presence of a qualified healthcare professional BEFORE attempting active use of the wheelchair.

DO NOT attempt to reach objects if you have to move forward in the seat.

DO NOT attempt to reach objects if you have to pick them up from the floor by reaching down between your knees.

DO NOT lean over the top of the back upholstery to reach objects behind you, as this may cause the wheelchair to tip over.

ALWAYS keep hands and fingers clear of moving parts to avoid injury.

DO NOT store items under seat - interference with seat latch may result.

DO NOT use an escalator to move a wheelchair between floors. Serious bodily injury may occur.

DO NOT engage or disengage the motor release levers until the power is in the OFF position.

DO NOT attempt to stop a moving wheelchair with wheel locks. Wheel locks are not brakes.

DO NOT operate on roads, streets or highways.

DO NOT climb, go up or down ramps or traverse slopes greater than 9°.

NEVER leave an unoccupied wheelchair on an incline.

Invacare strongly recommends proceeding down ramps or slopes at half speed or slower and to avoid hard braking or sudden stops.

DO NOT leave elevating legrests in the fully extended position when proceeding down ramps or slopes.

DO NOT attempt to move up or down an incline with a water, ice or oil film.

DO NOT attempt to drive over curbs or obstacles. Doing so may cause your wheelchair to turn over and cause bodily harm or damage to the wheelchair.

DO NOT leave the power button in the ON position when entering or exiting your wheelchair.

DO NOT attempt to lift the wheelchair by any removable (detachable) parts. Lifting by means of any removable (detachable) parts of the wheelchair may result in injury to the user or damage to the wheelchair.

DO NOT stand on the frame of the wheelchair.

DO NOT stand on the footplates/footboard. When getting in or out of the wheelchair, make sure that the footboard or footplates are in the upward position or swing the footrests towards the outside of the wheelchair.

Before attempting to transfer in or out of the wheelchair, every precaution should be taken to reduce the gap distance. Turn both casters parallel to the object you are transferring onto. Also be certain the power is OFF and wheel locks are engaged to prevent the wheels from moving.

DO NOT adjust the rear seat posts higher than the front seat posts.

Before performing any maintenance, adjustment or service verify that On/Off switch on the joystick is in the OFF position.

ALWAYS wear your seat positioning strap. The seat positioning strap is a positioning belt only. It is not designed for use as a safety device withstanding high stress loads such as auto or aircraft safety belts. If signs of wear appear, belt must be replaced immediately.

Avoid storing or using the wheelchair near open flame or combustible products. Serious injury or damage to property may result.

### **Wheelchairs with Powered Seating Systems Only**

DO NOT operate the seating system while on an incline.

DO NOT operate the seating system while the wheelchair is moving.

NEVER operate the wheelchair while in any tilted/reclined/back angle position over 20° RELATIVE TO THE VERTICAL POSITION. If the drive lock-out does not stop the wheelchair from operating in a tilt position over 20° RELATIVE TO THE VERTICAL POSITION, DO NOT operate the wheelchair. DO NOT attempt to adjust the drive lock-out. Have the wheelchair serviced by a qualified technician.

DO NOT operate tilt seat around children.

ALWAYS keep hands and feet out from underneath tilt seat - otherwise serious injury may result.

DO NOT tip the seating system/wheelchair without assistance.

Wiring must be routed and secured properly to ensure that wiring does not become entangled and damaged during normal operation of seating system.

Tilt Seats Only – Pinch point may occur when returning the tilted seat to the full upright position. Make sure the hands and body of the occupant, attendants and bystanders are clear of all pinch points before returning the tilted seat to the full upright position.

## **Accessories**

EXTREME care should be exercised when using oxygen in close proximity to electric circuits and other combustible materials. Contact your oxygen supplier for instruction in the use of oxygen.

## Batteries

The warranty and performance specifications contained in this manual are based on the use of deep cycle gel cell batteries. Invacare strongly recommends their use as the power source for this unit.

Carefully read battery/battery charger information prior to installing, servicing or operating your wheelchair.

The use of rubber gloves is recommended when working with batteries.

Some battery manufacturers mold a carrying strap and/or hold down flanges directly into the battery case. Batteries that interfere with the battery box cannot be used for these applications. Attempting to “wedge” a battery into a battery box may damage the box, the battery and/or be a fire hazard, resulting in serious injury or further damage to property.

## Charging Batteries

---

### **DANGER**

**When using an extension cord, use only a three wire extension cord having at least 16 AWG (American Wire Gauge) wire and the same or higher electrical rating as the device being connected. Use of improper extension cord could result in a risk of fire and electric shock. Three prong to two prong adapters should not be used. Use of three prong adapters can result in improper grounding and present a shock hazard to the user.**

---

NEVER attempt to recharge the batteries by attaching cables directly to the battery terminals.

DO NOT attempt to recharge the batteries and operate the wheelchair at the same time.

DO NOT operate wheelchair with extension cord attached to the AC cable.

DO NOT attempt to recharge the batteries when the wheelchair has been exposed to ANY type of moisture.

DO NOT attempt to recharge the batteries when the wheelchair is outside.

DO NOT sit in the wheelchair while charging the batteries.

DO NOT attempt to recharge batteries using BOTH the on-board battery charger AND an independent battery charger (plugged into the joystick charger port) at the SAME time. Doing so will reduce the life of the batteries.

READ and CAREFULLY follow the manufacturer’s instructions for each charger (supplied or purchased). If charging instructions are not supplied, consult a qualified technician for proper procedures.

AFTER charging batteries, ALWAYS make sure that the battery charger cord is securely wrapped and stored within the hook and loop strap assembly on the rear of the battery tray. Failure to do so may result in damage to the cord or personal injury to the user or bystanders.

Ensure the pins of the extension cord plug are the same number, size, and shape as those on the charger.

DO NOT under any circumstances cut or remove the round grounding plug from the charger AC cable plug or the extension cord plug.

Three prong to two prong adapters should not be used. Use of three prong adapters can result in improper grounding and present a shock hazard to the user.

## **Grounding Instructions**

DO NOT, under any circumstances, cut or remove the round grounding prong from any plug used with or for Invacare products. Some devices are equipped with three-prong (grounding) plugs for protection against possible shock hazards and fire. Where a two-prong wall receptacle is encountered, it is the personal responsibility and obligation of the customer to contact a qualified electrician and have the two-prong receptacle replaced with a properly grounded three-prong wall receptacle in accordance with the National Electrical Code. If you must use an extension cord, use ONLY a three-wire extension cord having the same or higher electrical rating as the device being connected. In addition, Invacare has placed RED/ORANGE warning tags on some equipment. DO NOT remove these tags.

## Rain Test

Invacare has tested its power wheelchairs in accordance with ISO 7176 “Rain Test.” This provides the end user or his/her assistant sufficient time to remove his/her power wheelchair from a rain storm and retain wheelchair operation.

DO NOT leave power wheelchair in a rain storm of any kind.

DO NOT use power wheelchair in a shower.

DO NOT store power wheelchair in a damp area for an extended period of time.

Direct exposure to excessive rain or dampness may cause the wheelchair to malfunction electrically and mechanically, may cause the wheelchair to prematurely rust or may damage the upholstery.

Check to ensure that the RED and BLACK battery terminal caps are secured in place, joystick boot is NOT torn or cracked where water can enter and that all electrical connections are secure at all times.

DO NOT use the wheelchair if the joystick boot is torn or cracked. If the joystick boot becomes torn or cracked, replace IMMEDIATELY.

## Weight Training

Invacare DOES NOT recommend the use of its wheelchairs as a weight training apparatus. Invacare wheelchairs have NOT been designed or tested as a seat for any kind of weight training. If occupant uses said wheelchair as a weight training apparatus, Invacare shall NOT be liable for bodily injury and the warranty is void.

## Weight Limitation

The Pronto M91 wheelchairs have the following weight limitations:

MODEL	WEIGHT LIMITATION
<b>STANDARD</b>	300 lb
<b>HEAVY DUTY</b>	400 lb
<b>STANDARD WITH FORMULA PTO PLUS</b>	275 lb
<b>HEAVY DUTY WITH FORMULA PTO PLUS</b>	375 lb



---

# SECTION 2—EMI INFORMATION

---

## **⚠ WARNING**

**CAUTION: IT IS VERY IMPORTANT THAT YOU READ THIS INFORMATION REGARDING THE POSSIBLE EFFECTS OF ELECTROMAGNETIC INTERFERENCE ON YOUR POWERED WHEELCHAIR.**

### Electromagnetic Interference (EMI) From Radio Wave Sources

Powered wheelchairs and motorized scooters (in this text, both will be referred to as powered wheelchairs) may be susceptible to electromagnetic interference (EMI), which is interfering electromagnetic energy (EM) emitted from sources such as radio stations, TV stations, amateur radio (HAM) transmitters, two way radios, and cellular phones. The interference (from radio wave sources) can cause the powered wheelchair to release its brakes, move by itself, or move in unintended directions. It can also permanently damage the powered wheelchair's control system. The intensity of the interfering EM energy can be measured in volts per meter (V/m). Each powered wheelchair can resist EMI up to a certain intensity. This is called its "immunity level." The higher the immunity level, the greater the protection. At this time, current technology is capable of achieving at least a 20 V/m immunity level, which would provide useful protection from the more common sources of radiated EMI.

There are a number of sources of relatively intense electromagnetic fields in the everyday environment. Some of these sources are obvious and easy to avoid. Others are not apparent and exposure is unavoidable. However, we believe that by following the warnings listed below, your risk to EMI will be minimized.

The sources of radiated EMI can be broadly classified into three types:

- 1) Hand-held Portable transceivers (transmitters-receivers with the antenna mounted directly on the transmitting unit. Examples include: citizens band (CB) radios, "walkie talkie", security, fire and police transceivers, cellular telephones, and other personal communication devices).

*NOTE: Some cellular telephones and similar devices transmit signals while they are ON, even when not being used.*

- 2) Medium-range mobile transceivers, such as those used in police cars, fire trucks, ambulances and taxis. These usually have the antenna mounted on the outside of the vehicle; and
- 3) Long-range transmitters and transceivers, such as commercial broadcast transmitters (radio and TV broadcast antenna towers) and amateur (HAM) radios.

*NOTE: Other types of hand-held devices, such as cordless phones, laptop computers, AM/FM radios, TV sets, CD players, cassette players, and small appliances, such as electric shavers and hair dryers, so far as we know, are not likely to cause EMI problems to your powered wheelchair.*

---

**⚠ WARNING**

**Powered Wheelchair Electromagnetic Interference (EMI)**

Because EM energy rapidly becomes more intense as one moves closer to the transmitting antenna (source), the EM fields from hand-held radio wave sources (transceivers) are of special concern. It is possible to unintentionally bring high levels of EM energy very close to the powered wheelchair's control system while using these devices. This can affect powered wheelchair movement and braking. Therefore, the warnings listed below are recommended to prevent possible interference with the control system of the powered wheelchair.

Electromagnetic interference (EMI) from sources such as radio and TV stations, amateur radio (HAM) transmitters, two-way radios, and cellular phones can affect powered wheelchairs and motorized scooters.

**FOLLOWING THE WARNINGS LISTED BELOW SHOULD REDUCE THE CHANCE OF UNINTENDED BRAKE RELEASE OR POWERED WHEELCHAIR MOVEMENT WHICH COULD RESULT IN SERIOUS INJURY.**

- 1) Do not operate hand-held transceivers (transmitters receivers), such as citizens band (CB) radios, or turn ON personal communication devices, such as cellular phones, while the powered wheelchair is turned ON;
- 2) Be aware of nearby transmitters, such as radio or TV stations, and try to avoid coming close to them;
- 3) If unintended movement or brake release occurs, turn the powered wheelchair OFF as soon as it is safe;
- 4) Be aware that adding accessories or components, or modifying the powered wheelchair, may make it more susceptible to EMI (NOTE: There is no easy way to evaluate their effect on the overall immunity of the powered wheelchair); and
- 5) Report all incidents of unintended movement or brake release to the powered wheelchair manufacturer, and note whether there is a source of EMI nearby.

**Important Information**

- 1) 20 volts per meter (V/m) is a generally achievable and useful immunity level against EMI (as of May 1994) (the higher the level, the greater the protection);
- 2) The immunity level of the product is unknown.

**Modification of any kind to the electronics of this wheelchair as manufactured by Invacare may adversely affect the RFI immunity levels.**

---

# SECTION 3—SAFETY/HANDLING OF WHEELCHAIRS

“Safety and Handling” of the wheelchair requires the close attention of the wheelchair user as well as the assistant. This manual points out the most common procedures and techniques involved in the safe operation and maintenance of the wheelchair. It is important to practice and master these safe techniques until you are comfortable in maneuvering around the frequently encountered architectural barriers.

Use this information only as a “basic” guide. The techniques that are discussed on the following pages have been used successfully by many.

Individual wheelchair users often develop skills to deal with daily living activities that may differ from those described in this manual. Invacare recognizes and encourages each individual to try what works best for him/her in overcoming architectural obstacles that they may encounter, however ALL WARNINGS and CAUTIONS given in this manual MUST be followed. Techniques in this manual are a starting point for the new wheelchair user and assistant with “safety” as the most important consideration for all.

## Stability and Balance

---

### **WARNING**

**ALWAYS** wear your seat positioning strap.

The seat positioning strap is a positioning belt **ONLY**. It is not designed for use as a safety device withstanding high stress loads such as auto or aircraft safety belts. If signs of wear appear, belt must be replaced immediately.

**DO NOT** climb, go up or down ramps or traverse slopes greater than 9°.

Invacare strongly recommends proceeding down ramps or slopes at half speed or slower and to avoid hard braking or sudden stops.

**DO NOT** leave elevating legrests in the fully extended position when proceeding down ramps or slopes.

---

To assure stability and proper operation of your wheelchair, you must at all times maintain proper balance. Your wheelchair has been designed to remain upright and stable during normal daily activities as long as you do not move beyond the center of gravity. **DO NOT** lean forward out of the wheelchair any further than the length of the armrests.

## Coping With Everyday Obstacles

*NOTE: For this procedure, refer to FIGURE 3.1.*

Coping with the irritation of everyday obstacles can be alleviated somewhat by learning how to manage your wheelchair. Keep in mind your center of gravity to maintain stability and balance.

While the walking beam allows to traverse up to a 3-inch bump or threshold, stopping after the wheels cross the bump poses a problem. The wheelchair cannot reverse over the bump at this point. Continue forward and then turn around.

While the M91 is designed for use primarily in and around the home, the provider should determine whether this wheelchair is suitable for the actual environment the wheelchair will be used in.

DO NOT go down ramp at full speed. Some seat/back positions will cause wheelchair to feel unstable.

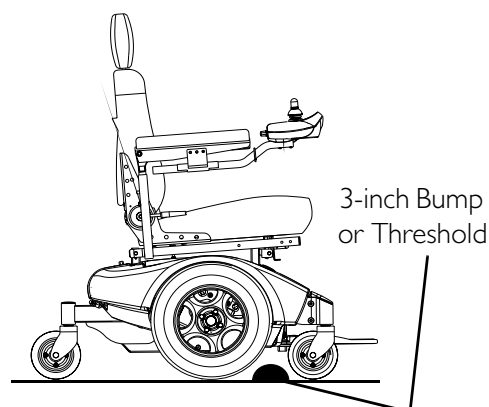

**FIGURE 3.1** Coping With Everyday Obstacles

---

### CAUTION

**Be aware of condition of ramp. Traction will be diminished/nonexistent on a slippery surface. Proceed with caution.**

---

## A Note to Wheelchair Assistants

When assistance to the wheelchair user is required, remember to use good body mechanics. Keep your back straight and bend your knees whenever tilting wheelchair or traversing curbs or other impediments.

Also, be aware of detachable parts such as arms or legrests. These must NEVER be used to move the wheelchair or as lifting supports, as they may be inadvertently released, resulting in possible injury to the user and/or assistant(s).

When learning a new assistance technique, have an experienced assistant help you before attempting it alone.

## Lifting/Stairways

### **⚠ WARNING**

**DO NOT** attempt to move an occupied power wheelchair between floors using a stairway. Use an elevator to move an occupied power wheelchair between floors. If moving a power wheelchair between floors by means of a stairway, the occupant **MUST** be removed and transported independently of the power wheelchair.

Extreme caution is advised when it is necessary to move an unoccupied power wheelchair up or down the stairs. Invacare recommends using two assistants and making thorough preparations.

Use **ONLY** secure, nondetachable parts for hand-hold supports.

It is strongly recommended to lift the wheelchair only by the rear frame and the front forks - otherwise injury or damage may occur.

**DO NOT** attempt to lift the wheelchair by any removable (detachable) parts. Lifting by means of any removable (detachable) parts of a wheelchair may result in injury to the user or damage to the wheelchair.

The weight of the wheelchair with batteries and without the user is between 203 and 318 lbs. Use proper lifting techniques (lift with your legs) to avoid injury.

*NOTE: For this procedure, refer to FIGURE 3.2.*

Follow this procedure for moving the wheelchair between floors when an elevator is NOT available or lifting the wheelchair is necessary:

1. Remove the occupant from the wheelchair.
2. Bend your knees and keep your back straight.
3. Using the rear frame and the front edge of the front forks as hand hold supports, transfer the wheelchair base to the desired location.

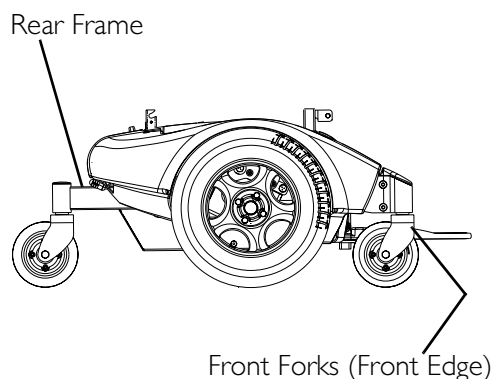

**FIGURE 3.2** Lifting/Stairways - Hand Hold Supports

**⚠ WARNING: ESCALATORS**

**DO NOT** use an escalator to move a wheelchair between floors. Serious bodily injury may occur.

---

## Transferring To and From Other Seats

---

**⚠ WARNING**

**ALWAYS** turn the wheelchair power **OFF** and engage the **Motor Release Levers** to prevent the wheels from moving **BEFORE** attempting to transfer in or out of the wheelchair. Also, make sure every precaution is taken to reduce the gap distance by aligning both the front **AND** rear casters parallel with the object you are transferring onto.

---

**CAUTION**

**When transferring, position yourself as far back as possible in the seat. This will prevent broken screws, damaged upholstery and the possibility of the wheelchair tipping forward.**

---

*NOTE: For this procedure, refer to FIGURE 3.3.*

*NOTE: This activity may be performed independently provided you have adequate mobility and upper body strength.*

1. Position the wheelchair as close as possible along side the seat to which you are transferring, with the rear casters pointing away from it.
2. After the wheelchair is positioned properly for transfer, verify that the Motor Release Levers are engaged. Refer to [Engaging/Disengaging Motor Release Lever](#) on page 57.
3. Flip back or remove arm on side of wheelchair you are transferring from.
4. Shift body weight into seat with transfer.

During independent transfer, little or no seat platform will be beneath you. Use a transfer board if at all possible.



**FIGURE 3.3** Transferring To and From Other Seats

## Percentage of Weight Distribution

### ⚠ WARNING

**DO NOT** attempt to reach objects if you have to move forward in the seat or pick them up from the floor by reaching down between your knees.

Many activities require the wheelchair user to reach, bend and transfer in and out of the wheelchair. These movements will cause a change to the normal balance, center of gravity, and weight distribution of the wheelchair. To determine and establish your particular safety limits, practice bending, reaching and transferring activities in several combinations in the presence of a qualified healthcare professional **BEFORE** attempting active use of the wheelchair.

Proper positioning is essential for your safety. When reaching, leaning, bending or bending forward, it is important to use the casters as a tool to maintain stability and balance.

The Pronto M9I wheelchairs have the following weight limitations:

MODEL	WEIGHT LIMITATION
STANDARD	300 lb
HEAVY DUTY	400 lb
STANDARD WITH FORMULA PTO PLUS	275 lb
HEAVY DUTY WITH FORMULA PTO PLUS	375 lb

## Reaching, Leaning and Bending - Forward

### ⚠ WARNING

**DO NOT** attempt to reach objects if you have to move forward in the seat or pick them up from the floor by reaching down between your knees.

*NOTE: For this procedure, refer to FIGURE 3.4.*

Position the front AND rear casters so that they are extended as far forward as possible and engage Motor Release Levers.



**FIGURE 3.4** Reaching, Leaning and Bending - Forward

## Reaching and Bending - Backward

---

### **⚠ WARNING**

**DO NOT lean over the top of the back upholstery. This will change your center of gravity and may cause you to tip over.**

---

*NOTE: For this procedure, refer to FIGURE 3.5.*

Position wheelchair as close as possible to the desired object. Point the front AND rear casters rearward to create the longest possible wheelbase. Reach back only as far as your arm will extend without changing your sitting position.



**FIGURE 3.5** Reaching and Bending - Backward



# SECTION 4—SAFETY INSPECTION/ TROUBLESHOOTING

*NOTE: Every six months or as necessary take your wheelchair to a qualified dealer for a thorough inspection and servicing. Regular cleaning will reveal loose or worn parts and enhance the smooth operation of your wheelchair. To operate properly and safely, your wheelchair must be cared for just like any other vehicle. Routine maintenance will extend the life and efficiency of your wheelchair.*

## Safety Inspection Checklists

### All Wheelchairs

---

#### CAUTION

**As with any vehicle, wheels and tires should be checked periodically for cracks and wear and should be replaced as necessary.**

---

Initial adjustments should be made to suit your personal body structure needs and preference. Thereafter follow these maintenance procedures:

#### Inspect/Adjust Initially

- Ensure wheelchair rolls straight (no excessive drag or pull to one side).
- Ensure arms are secure but easy to release and adjustment levers engage properly (on ASBA only).
- Ensure adjustable height arms operate and lock securely.
- Ensure armrest pads sit flush against arm tubes.
- Ensure seat is secured to wheelchair frame.
- Ensure seat release latch is functional. Replace if necessary.
- Ensure wheel mounting nuts are secure on drive wheels.
- Ensure there is no excessive side movement or binding when drive wheels are lifted and spun when disengaged (freewheeling).
- Ensure wheel/fork assembly has proper tension when caster is spun. Caster should come to a gradual stop.
- Loosen/tighten caster locknut if wheel wobbles noticeably or binds to a stop.
- Ensure all caster/wheel/fork/headtube fasteners are secure.
- Inspect tires for flat spots and wear.
- Inspect and clean the stability lock gears.
- Clean upholstery and armrests.
- Check that all labels are present and legible. Replace if necessary.

**Inspect/Adjust Weekly**

- Ensure seat is secured to wheelchair frame.
- Ensure seat and/or back upholstery have no rips and do not sag. Replace if necessary.
- Ensure seat release latch is not worn and is functional. Replace if necessary.
- Inspect tires for flat spots and wear.
- Ensure arm pivot points are not worn and/or loose. Replace if necessary.
- Inspect and clean the stability lock gears. Replace if worn.

**Inspect/Adjust Monthly**

- Ensure wheel mounting nuts are secure on drive wheels.
- Ensure there is no excessive side movement or binding when drive wheels are lifted and spun when disengaged (free-wheeling).
- Ensure wheel/fork assembly has proper tension when caster is spun. Caster should come to a gradual stop.
- Loosen/tighten caster locknut if wheel wobbles noticeably or binds to a stop.
- Ensure all caster/wheel/fork/headtube fasteners are secure.
- Inspect for any loose hardware on the wheelchair.
- Inspect the seat positioning strap for signs of wear. Replace if worn or damaged.
- Ensure that the buckle on the seat positioning strap latches. Replace if necessary.
- Verify that the hardware that attaches the seat positioning strap to the seat frame is secure and undamaged. Replace if necessary.

**Inspect/Adjust Periodically**

- Ensure wheelchair rolls straight (no excessive drag or pull to one side).
- Ensure arms are secure but easy to release and adjustment levers engage properly (on ASBA only).
- Ensure adjustable height arms operate and lock securely.
- Ensure arm pivot points are not worn and/or loose. Replace if necessary.
- Ensure armrest pads sit flush against arm tubes.
- Ensure seat and/or back upholstery have no rips and do not sag. Replace if necessary.
- Ensure seat release latch is not worn. Replace if necessary.
- Inspect and clean the stability lock gears. Replace if worn.
- Clean upholstery and armrests.
- Inspect charger AC power cord for damage. Replace if necessary.
- Check that wiring is routed and secured properly to ensure that wiring does NOT become entangled and damaged.

- Inspect electrical components for signs of corrosion. Replace if corroded or damaged.
- Check that all labels are present and legible. Replace if necessary.

### **Additional Requirements for Wheelchairs with Formula PTO Plus Systems**

#### **Inspect/Adjust Initially**

- Make sure all electrical connections are secure.
- Check that wiring is routed and secured properly to ensure that wiring does NOT become entangled and damaged during normal operation of seating system.
- Check limit switch position.
- Make sure drive lock-out operates properly.
- Make sure tilt operates smoothly and properly.
- Make sure actuator mechanism and tilt tracks are clean.

#### **Inspect/Adjust Weekly**

- Check that wiring is routed and secured properly to ensure that wiring does NOT become entangled and damaged during normal operation of seating system.

#### **Inspect/Adjust Monthly**

- Make sure all electrical connections are secure.
- Make sure tilt operates smoothly and properly.

#### **Inspect/Adjust Periodically**

- Make sure drive lock-out operates properly.
- Check limit switch position.
- Make sure actuator mechanism and tilt tracks are clean.

## Troubleshooting Guide

### All Wheelchairs

SYMPTOM	PROBABLE CAUSE	SOLUTIONS
Batteries draw excessive current when charging.	Battery failure.  Electrical malfunction.	Have batteries checked for shorted cell. Replace if necessary.  Contact Dealer/Invacare for service.
Battery indicator flashes the charge level is low - immediately after recharge.	Battery failure.  Malfunctioning battery charger.  Electrical malfunction	Check batteries for shorted cell. Replace if necessary.  Contact Dealer/Invacare for service.  Contact Dealer/Invacare for service.
Battery indicator flashes the charge level is low - too soon after being recharged.	Batteries not charged.  Weak batteries	Have charger checked.  Replace batteries if necessary. Contact Dealer/Invacare for service.
Motor “chatters” or runs irregular.	Electrical malfunction.	Contact Dealer/Invacare for service.
Only one drive wheel turns.	Electrical malfunction.  One motor lock is disengaged.	Contact Dealer/Invacare for service.  Engage motor lock.
Joystick erratic or does not respond as desired.	Damaged motor coupling.  Electrical malfunction.  Controller programmed improperly.	Contact Dealer/Invacare for service.  Contact Dealer/Invacare for service.  Reprogram controller (Refer to MK5™ EX™ or MK5 NX™ electronics owner’s manual supplied with wheelchair).
Wheelchair does not respond to commands.	Poor battery terminal connection.	Have terminals cleaned.
Power indicator off - even after recharging.	Electrical malfunction.	Contact Dealer/Invacare for service.

*NOTE: For additional troubleshooting information and explanation of error codes, refer to the Electronics Manual supplied with each wheelchair.*

## Wheelchairs with Formula PTO Plus Systems

SYMPTOM	PROBABLE CAUSE	SOLUTIONS
Wheelchair Power ON but does not drive	System tilted beyond drive lock-out angle (20°)	<b>Return to neutral position (upright).</b> Contact Invacare/Dealer for service if this does not solve the problem.
Seating system not functioning.	Low batteries.  Faulty electrical connection.  Blown fuse.	Charge batteries.  Check all connections.  Have wiring harness replaced by a qualified technician.

## Checking Battery Charge Level

The following “Do’s” and “Don’ts” are provided for your convenience and safety.

DON'T	DO
Don't perform any installation or maintenance without first reading this manual.	Read and understand this manual and any service information that accompanies a battery and charger before operating the wheelchair.
Don't perform installation or maintenance of batteries in an area that could be damaged by battery spills.	Move the wheelchair to a work area before cleaning terminals, or opening battery box.
Don't make it a habit to discharge batteries to the lowest level.	Recharge as frequently as possible to maintain a high charge level and extend battery life.
Don't use randomly chosen batteries or chargers.	Follow recommendations in this manual when selecting a battery or charger.
Don't put new batteries into service before charging.	Fully charge a new battery before using.
Don't tip or tilt batteries.	Use a carrying strap to remove, move or install a battery.
Don't tap on clamps and terminals with tools.	Push battery clamps on the terminals. Spread clamps wider if necessary.
Don't mismatch your battery and chargers.	Use <b>ONLY</b> a GEL charger for a GEL battery.

# SECTION 5—WHEELCHAIR OPERATION

---

## **⚠ WARNING**

**After ANY adjustments, repair or service and BEFORE use, make sure that all attaching hardware is tightened securely - otherwise injury or damage may result.**

**Set-up of the Electronic Control Unit is to be performed only by a qualified technician. The final adjustments of the controller may affect other activities of the wheelchair. Damage to the equipment could occur if improperly setup or adjusted.**

---

## **Operating the Wheelchair**

*NOTE: For this procedure, refer to FIGURE 5.1.*

### **Turning the Power On/Off**

1. To turn the power ON, perform one of the following steps:
  - A. SPJ™ -80 JOYSTICKS - Move the On/Off switch Up or Down. The switch automatically retracts back to center position.
  - B. DPJ™ JOYSTICKS - Move the On/Off switch Up to the Middle or Top position.
  - C. MPJ™ JOYSTICKS - Move the On/Off switch Forward to the On position.
  - D. SPJ+ JOYSTICKS - Press the On/Off button.

*NOTE: After turning power on, all indicators will light briefly and the display gauge will indicate one of the following:*

- A. *THE CURRENT BATTERY CHARGE - Information gauge shows all LED's lit or partial LED's lit.*
  - B. *OUT OF NEUTRAL AT POWER UP - Information Gauge shows all LED's flashing slowly. This occurs when the power is turned on when the joystick is out of neutral. This feature prevents sudden and unexpected movements of the power wheelchair. In these cases, release the joystick and restart the unit.*
2. Turning the power Off can be achieved by performing one of the following steps:
  - A. SPJ-80 JOYSTICKS - Move the On/Off switch Up or Down. The switch automatically retracts back to center position.
  - B. DPJ JOYSTICKS - Move the On/Off switch Down to the Off position.
  - C. MPJ JOYSTICKS - Move the On/Off switch Back to the Off position.
  - D. SPJ+ JOYSTICKS - Press the On/Off button.

## Using the Joystick to Drive the Wheelchair

The joystick is located at the front of the joystick housing and provides smooth control of speed and direction. It is equipped with 360 degrees of mobility for ease of operation. The joystick is spring-loaded, and automatically returns to the upright (neutral) position when released. Pushing the joystick in a given direction causes the wheelchair to move in that direction.

The joystick has proportional drive control, meaning that the further it is pushed from the upright (neutral) position, the faster the wheelchair moves. The maximum speed, however, is limited by the setting of the speed-control knob.

To slow the wheelchair to a stop, simply release the joystick. The wheelchair has automatic speed and direction compensation to minimize corrections.

When first learning to drive, select a slow speed and try to drive the wheelchair as slowly as possible by pushing the joystick slightly forward. This exercise will help you learn to utilize the full potential of the proportional control and allow you to start and stop smoothly.

To drive the wheelchair, perform the following:

1. Adjust speed control knob to the appropriate setting.
2. Turn the power on. Refer to [Turning the Power On/Off](#) on page 38.
3. Maneuver the joystick in the following manner:

MOVEMENT	ACTION
FORWARD	Push forward on the joystick.
REVERSE	Pull back on the joystick.
Turn RIGHT	Move the joystick RIGHT.
Turn LEFT	Move the joystick LEFT.
STOP	Release the joystick and the wheelchair will quickly slow down.

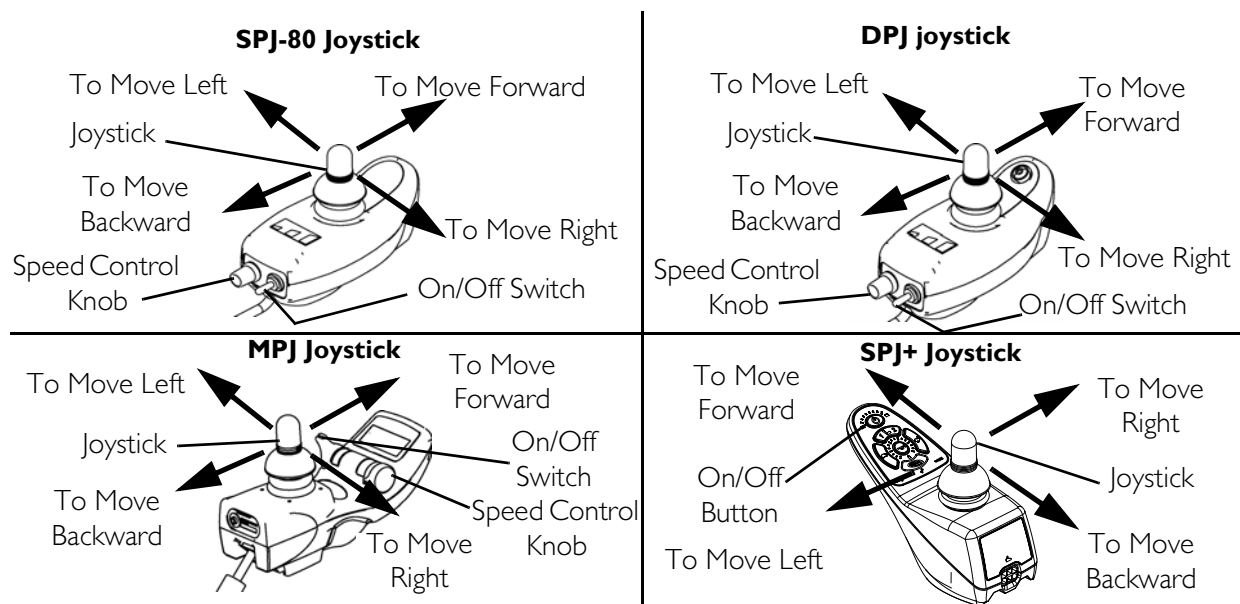

**FIGURE 5.1** Operating the Wheelchair

*NOTE:* For specific information about the joystick installed on the wheelchair, refer to one of these procedures:

- [SPJ-80 Joystick Switches and Indicators](#) on page 42.
- [DPJ Joystick Switches and Indicators](#) on page 44.
- [MPJ Joystick Switches and Indicators](#) on page 45.
- [SPJ+ Joystick Switches and Indicators](#) on page 48.

## Operating the Formula PTO Plus System

### **⚠ WARNING**

**Pinch points may occur when returning the seat from any tilted position to the full upright position. Make sure the hands and body of the occupant, attendants and bystanders are clear of all pinch points before returning the seat to the full upright position.**

**DO NOT** operate the tilt function near or under a fixed object such as a table or desk.

*NOTE:* For this procedure, refer to FIGURE 5.2.

*NOTE:* This procedure applies to wheelchairs with the Formula PTO Plus System ONLY.

*NOTE:* If the wheelchair is equipped with switch options (TAC and DPJ joystick), scan to the correct ECU or Auxiliary Mode and activate the control device in the corresponding "forward" direction to operate the tilt function. Refer to the electronics manual supplied with your wheelchair for complete switch option operating instructions.



---

**⚠ WARNING****A NOTE ABOUT DRIVE LOCK-OUT**

**NEVER** operate the wheelchair or elevate/lower the seat while the back is in any tilted/reclined/back angle position over 20° relative to the vertical position. If the drive lock-out does not stop the wheelchair from operating or the seat from elevating/lowering in a tilt/recline/back angle position over 20° relative to the vertical position, **DO NOT** operate the wheelchair or elevate/lower the seat. **DO NOT** attempt to adjust the drive lock-out. Have the wheelchair serviced by a qualified technician.

The wheelchair user **MUST** have a clear line of sight to drive safely. On initial chair delivery and after adjusting the back angle, drive lock-out switch or the tilt system, tilt the seat back to the farthest driving position immediately before drive lock-out engages and ensure there is a clear line of sight present in which to drive the wheelchair. If a clear line of sight is not present, have the back angle repositioned or readjust the lockout angle such that safe driving with a clear line of sight is achieved. **Otherwise injury or damage may occur.**

---

The LED on the single function toggle switch will light when the drive lock-out feature has been activated. Drive lock-out is a feature designed to prevent the wheelchair from being driven after the seating system has been tilted beyond 20°\* relative to the horizontal seat position. The back can be positioned at a 10° relative offset to the seat base, thereby resulting in a back angle potential of 30° before which the drive lock-out is activated. This may affect the wheelchair user's line of sight while driving. Make sure the wheelchair user can see properly to ensure safe driving.

\*NOTE: Refer to *Typical Product Parameters* on page 17 for tilt angle ranges.

NOTE: The directions indicated in the following procedures apply to wheelchairs with the single function toggle switch mounted on the right side of the wheelchair.

**Increasing the Tilt Angle**

1. Make sure the wheelchair is on a level surface.
2. Push the single function toggle switch Forward towards the Front of the wheelchair until the desired angle is achieved.

**Decreasing the Tilt Angle**

1. Pull the single function toggle switch Back towards the Rear of the wheelchair until the desired angle is achieved.

Single Function Toggle Switch

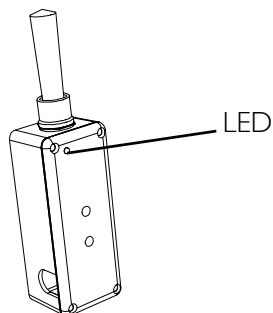

Full Upright Position

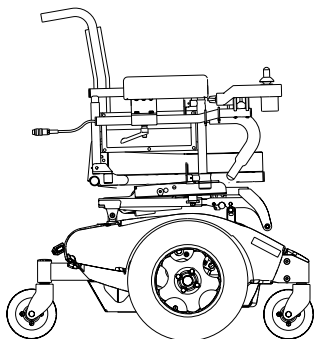

Full Tilt Position

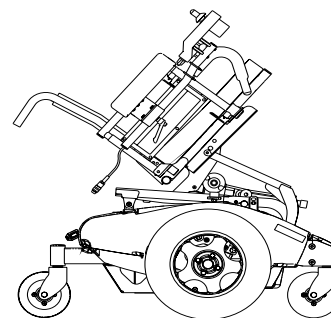

FIGURE 5.2 Operating the Formula PTO Plus System

## SPJ-80 Joystick Switches and Indicators

NOTE: For this procedure, refer to FIGURE 5.3.

NOTE: The SPJ-80 joystick must be used with the MK5 NX™-80 (80 amp) controller.

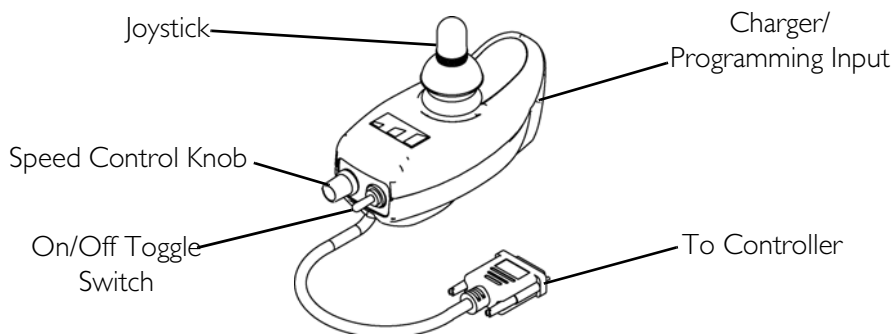

FIGURE 5.3 SPJ-80 Joystick Switches and Indicators

## **On/Off Toggle Switch**

This toggle switch is located at the back of the joystick housing.

## **Speed Control Knob**

The speed control knob is located on the back of the joystick housing. This rotary knob is used for controlling the speed and acceleration of the wheelchair.

1. Turn the knob clockwise to increase the speed of the wheelchair.
2. Turn the knob counterclockwise to decrease the speed of the wheelchair.

## **Joystick**

The joystick provides proportional drive control of speed and direction.

## **Battery Gauge Display**

Located at the rear of the joystick housing, it provides information on the remaining charge in the batteries. At full charge, all six segments of the bar graph are lit. The lower the battery charge the fewer number of segments light up. Once the battery level reaches the point where only one segment is lit, the last RED bar will start to flash on and off to indicate that the user should charge the batteries as soon as possible.

The BGD also serves as a system diagnostic device when a fault is detected by the control module. A specific number of flashes of the last two RED bars (up to eight flashes) start to flash on and off separated by a pause to indicate the type of fault detected. A chart of the diagnostic indications is given in Diagnostic Code of the Electronics Manual, part number 1122140.

The joystick has proportional drive control, meaning that further the joystick is pushed from the upright (neutral) position, the faster the wheelchair moves. Your top speed, however, is limited by the setting of the speed-control knob and programmed settings.

To slow the wheelchair to a stop, simply release the joystick. The wheelchair has automatic speed and direction compensation to minimize corrections.

## **Charger/Programming Input**

Located at the front of the joystick housing. This provides easy access for charging the wheelchair batteries. This port also serves as the Remote Programmer Communication connection.

## DPJ Joystick Switches and Indicators

*NOTE: For this procedure, refer to FIGURE 5.4.*

*NOTE: The DPJ joystick must be used with the MK5 EX™ controller.*

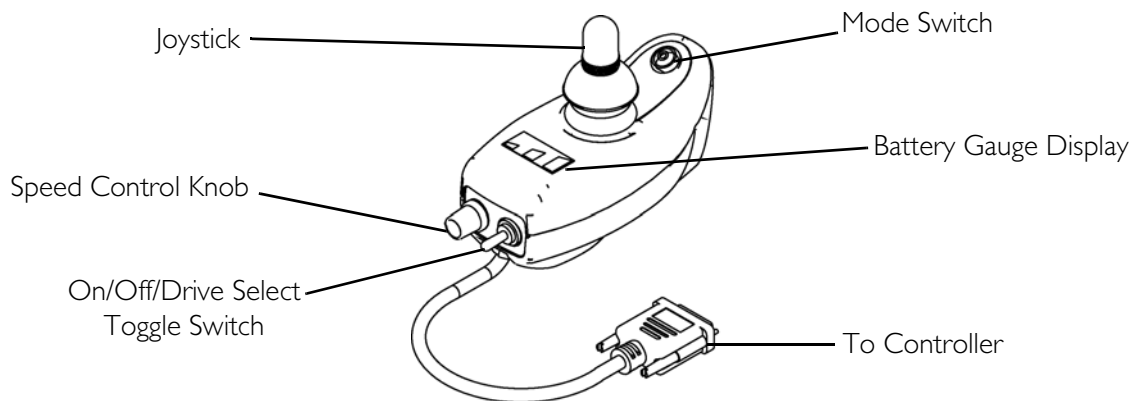

**FIGURE 5.4** DPJ Joystick Switches and Indicators

### Drive Select Toggle Switch

The three position drive select toggle switch is located at the back of the joystick housing. This switch allows the operator to select the type of operation or performance which best suits a particular control need or situation. The DRIVE 1 program uses performance values which are independent of those used for the DRIVE 2 program. As an example, an operator may have a control need for spasticity in the morning and a very different need in the afternoon. DRIVE 1 can be programmed for higher speeds and quicker response while DRIVE 2 can be programmed for slower speeds and less responsiveness or vice versa.

#### Selecting the Drive Mode

1. To select DRIVE 1 mode, move the toggle Up.
2. To select DRIVE 2 mode, move the toggle to the Middle position.

### Speed Control knob

The speed control knob is located at the back of the joystick housing.

1. Turn the knob clockwise to increase the maximum speed of the wheelchair.

### Joystick

The joystick provides proportional drive control of speed and direction.

## Mode (On/Off) Switch

The mode (On/Off) switch is a push button switch located at the front of the joystick. When an optional actuator control [Two Actuator control, (TAC)] is present, pushing the switch will change the controller mode to control the chairs actuators through the joystick. The mode switch LED indicator will be On. Push the switch again to return to normal joystick driving. The mode switch LED indicator will be off.

## Battery Gauge Display (BGD)

Located at the rear of the joystick housing, the BGD provides information on the remaining charge in the batteries. At full charge, all six segments of the bar graph are lit. As the battery discharges, the farthest right segment will go out until only the RED bar is lit. At this level, the last RED bar will start to flash on and off to indicate that the user should charge the batteries as soon as possible.

The BGD also serves as a system diagnostic device when a fault is detected by the control module. A specific number of flashes of the last two RED bars (up to eight flashes) separated by a pause will indicate the type of fault detected. This information is useful to a qualified technician when making repairs or reprogramming the electronics.

## MPJ Joystick Switches and Indicators

*NOTE: For this procedure, refer to FIGURE 5.5.*

*NOTE: The MPJ joystick must be used with the MK5 EX controller.*

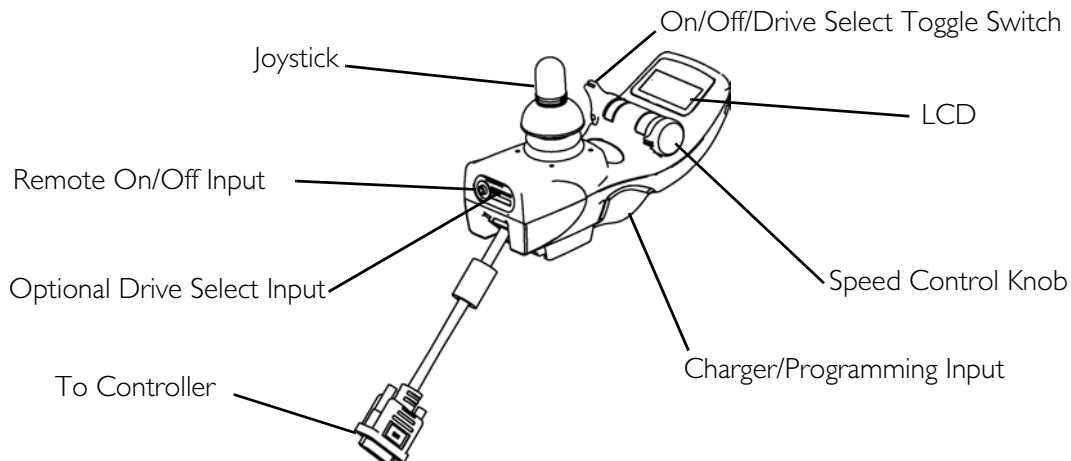

**FIGURE 5.5** MPJ Joystick Switches and Indicators

## Drive Select Toggle Switch

A three position drive select toggle switch is located on the display module in the lower right corner. The drive select position is momentary.

This switch allows the operator to select the type of operation or performance which best suits a particular control need or situation. The DRIVE 1 program uses performance values which are independent of those used for the DRIVE 2 or 3 or 4 program. As an example, an operator may have a control need for spasticity in the morning and a very different need in the afternoon. DRIVE 1 can be programmed for higher speeds and quicker response while DRIVE 2 can be programmed for slower speeds and less responsiveness or vice versa. The other two drive programs could be indoor and outdoor versions of DRIVE 1 and DRIVE 2.

### Selecting the Drive Mode

1. Move the toggle Up and release. DRIVE 1 will appear on LCD.
2. Move the toggle Up and release again. DRIVE 2 will appear on LCD.
3. Move the toggle Up and release again. DRIVE 3 will appear on LCD.
4. Move the toggle Up and release again. DRIVE 4 will appear on LCD.
5. Move the toggle Up and release one more time to select DRIVE 1.

## Speed Control

The speed control knob is located on the side of the joystick housing.

1. Rotate the knob forward to increase the speed of the wheelchair to the programmed max speed.

## Joystick

The joystick provides proportional drive control of speed and direction.

## LCD Display

The LCD Display is located in front of the joystick and provides information on the status of the wheelchair through a 2 line by 12 character length backlit display. The LCD display is readable in both bright sunlight and complete darkness.

During normal operation the active drive is displayed on the left half of the first line. The left half of the second line shows the Battery Discharge Indicator (BDI). It provides information on the remaining charge in the batteries. At full charge, solid blocks fill in all five segments between E (Empty) and F (Full). As the battery becomes discharged, the furthest right segments will progressively disappear a half bar at a time until no segments appear between E and F. At this level, the word "Recharge" will appear on the second line to indicate that the user should charge the batteries as soon as possible.

The right half of the display is the Information Center. The Information Center displays current data on the wheelchair. FIGURE 5.6 shows the factory default odometer display. The top line shows the unit of measured MI (miles). The second line is the value, 0000 (total miles driven).

The Information Center can display:

ITEM	DESCRIPTION
Speedometer	Current Wheelchair Speed - MPH/KMH
Trip Odometer	Distance traveled since the wheelchair was last powered ON
Odometer	Total Distance Traveled (Factory Default) - MI/KM
Trip Amp-Hour meter	Battery Capacity consumed since the wheelchair was last powered ON - AH
Battery Volts	Current Battery Voltage - VOLT
Battery Current	Battery current being used - AMP
Load Test Results	Current battery condition based on a load test - BATT

If a fault is detected, the cause of the fault will be scrolled across the second line of the display.

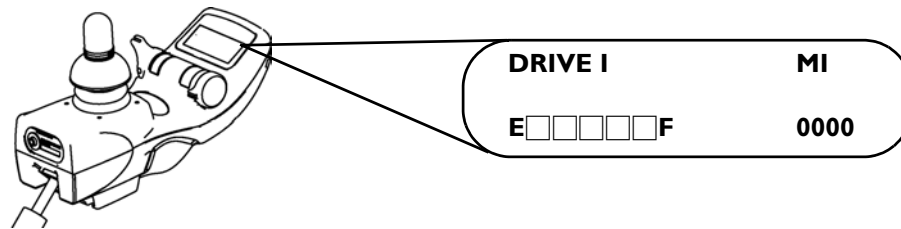

**FIGURE 5.6** MPJ Joystick Switches and Indicators - LCD Display

## Emergency Stop/Reset Switch

The emergency stop/reset switch is used to stop the wheelchair and to select the operating mode for the wheelchair. The switch input is located on the control module next to the joystick input. An emergency stop/reset switch is needed whenever any of the following operating modes are programmed:

- Environmental Controls (E.C.U.) - including recliner controls
- 3 Speed Mode in Momentary
- Latched Modes
- Pneumatic Control
- Stand-by Mode
- RIM Control
- Remote Drive Selection Mode
- Information Center Display Selection (does not require Reset activation at power up)

If any of the above modes are selected, the control will require activation of the switch immediately after the power switch is turned on in order to enter the drive mode. The second line of the LCD will display - PRESS RESET.

## Emergency Stop/Reset Input

The input accepts a 1/8-inch diameter Phono connector. The emergency stop/reset switch must be an open contact for normal driving and a closed contact to activate the emergency stop/reset function.

PIN	DESIGNATION
TIP	Emergency Stop/Reset
RING	COMMON (B-)

## Remote On/Off Switch

The remote on/off switch input allows the power switch to be operated by an ability switch (normally open momentary switch with mono plug). To use the remote on/off feature, the Drive Select/On/Off switch must be in the On position. Each activation of the ability switch will alternately turn the joystick On or Off.

## SPJ+ Joystick Switches and Indicators

*NOTE: For the following information, refer to FIGURE 5.7.*

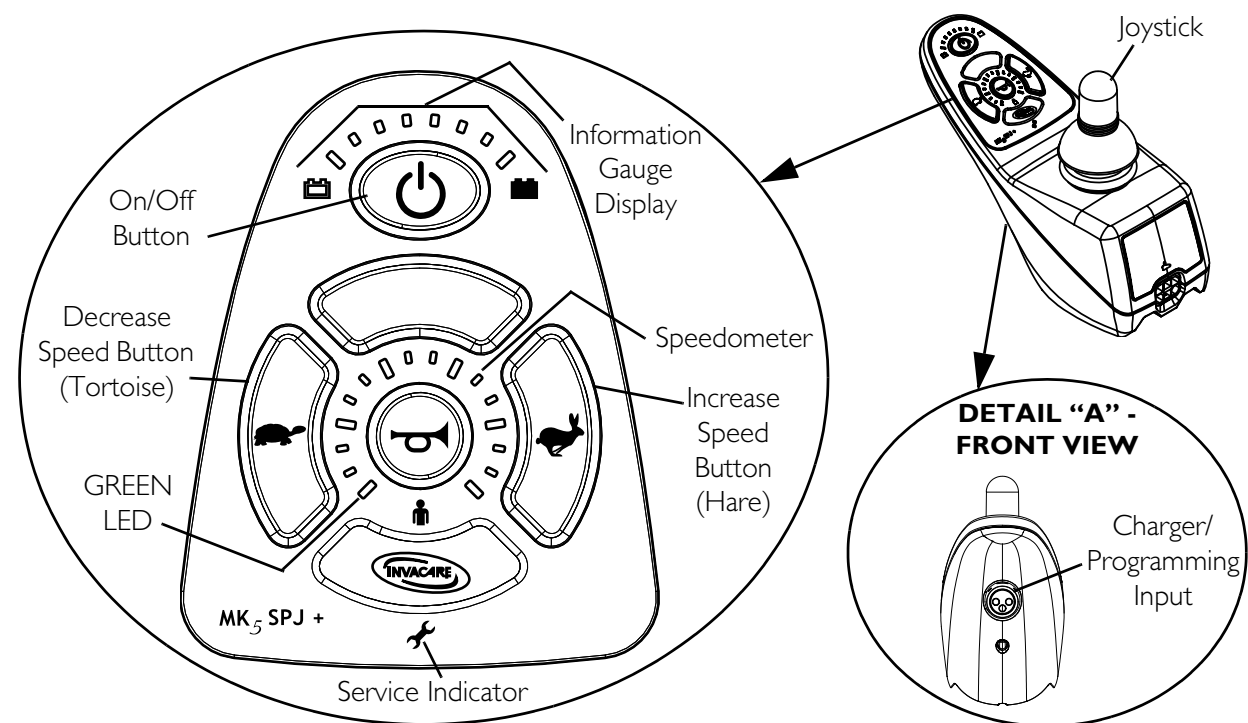

**FIGURE 5.7** SPJ+ Joystick Switches and Indicators

## On/Off Button

This button is located at the front of the joystick housing. It is used to turn the wheelchair on and off, to remove the joystick from sleep mode (if programmed) and to lock or unlock the joystick (if programmed).



## Speedometer

The speedometer is used to show the maximum speed. The right-most LED indicates current maximum speed setting. The bottom left GREEN LED flashes to indicate that the joystick is in speed limit mode. Speed limit mode limits the drive speed to a pre-programmed value, typically when the seat has been elevated and the wheelchair is required to drive at 20% speed.

## Speed Control Buttons

The speed control buttons (tortoise button (🐢) and hare button (🐇)) are used to set and adjust the maximum speed.

1. To adjust the speed, perform one of the following:
  - Adjust Speed in 20% Increments (5 Speed Mode) - Press the tortoise button (🐢) or hare button (🐇) to decrease/increase the speed in 20% increments. The larger bars in the speedometer will light.
  - Adjust Speed in Smaller Increments (VSP Mode) - Perform the following steps:
    - i. Press and hold both the tortoise button (🐢) and hare button (🐇) until the joystick beeps.
    - ii. Perform one of the following:
      - Press the tortoise button (🐢) or hare button (🐇) to decrease/increase the speed in 20% increments. The larger bars in the speedometer will light.
      - Press and hold the tortoise button (🐢) or hare button (🐇) to decrease/increase the speed in smaller increments. The smaller bars in the speedometer will light.

## Joystick

The joystick has proportional drive control, meaning that further the joystick is pushed from the upright (neutral) position, the faster the wheelchair or seat moves. Your top speed, however, is limited by the programmed settings.

To slow the wheelchair to a stop, simply release the joystick. The wheelchair has automatic speed and direction compensation to minimize corrections.

## Charger/Programming Input

The charger/programming input is located at the front of the joystick housing. This provides easy access for charging the wheelchair batteries. This port also serves as the Remote Programmer Communication connection. Driving is prevented while the system is charging.

## Service Indicator

The AMBER service indicator will light when an error or fault occurs. A chart of the diagnostic indications is given in Diagnostic Code of the electronics manual supplied with the wheelchair.

## Information Gauge Display

Located on the front of the joystick housing, it provides the following information to the user on the status of the wheelchair -

1. Power is on.
2. True state-of-battery-charge, including notification of when the battery requires charging:
  - A. GREEN LEDs are lit, indicating well charged batteries.
  - B. AMBER LEDs are lit, indicating batteries are moderately charged. Recharge batteries before taking a long trip.
  - C. RED LEDs are lit, indicating batteries are running out of charge. Recharge batteries as soon as possible.

The Information Gauge display also serves as a system diagnostic device when a fault is detected by the control module. A specific number of flashes of the LEDs indicate the type of fault detected. Refer to the table for the diagnostic indications of the wheelchair status.

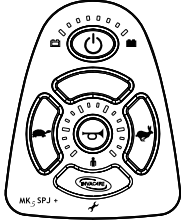
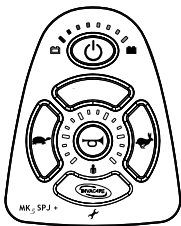
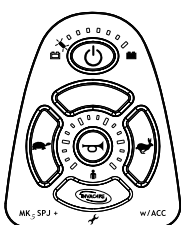
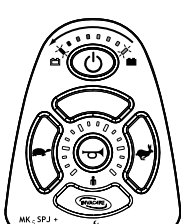
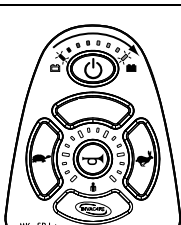
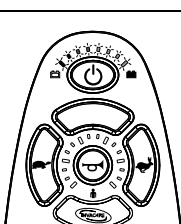
DISPLAY	DESCRIPTION	DEFINITION	COMMENTS
	All LEDs are off.	Power is off.	
	All LEDs are on.	Power is on.	Fewer than three LEDs on implies reduced battery charge.
	Left RED LED is flashing.	Battery charge is low.	The batteries should be charged as soon as possible.
	Right to Left “chase”.	Joystick is being brought out of LOCK mode.	To UNLOCK the joystick, press the horn button two times within ten (10) seconds.
	Left to Right “chase” alternating with steady display.	Joystick is in programming, inhibit and/or charging mode.	The steady LEDs indicate the current state of the battery charge.
	All LEDs are flashing slowly.	Joystick has detected Out-of-Neutral-at-Power-Up mode.	Release the joystick back to Neutral.

# SECTION 6—ARMS

## ⚠ WARNING

After **ANY** adjustments, repair or service and **BEFORE** use, make sure that all attaching hardware is tightened securely - otherwise injury or damage may result.

Before performing any maintenance, adjustment or service verify that **ON/OFF** switch on the joystick is in the **OFF** position.

## Installing/Removing Flip Back Armrests

## ⚠ WARNING

Make sure the flip back armrest release and height adjustment levers are in the locked position before using the wheelchair.

*NOTE: For this procedure, refer to FIGURE 6.1.*

*NOTE: Flip back armrest release lever must be in unlocked position when placing armrest into the arm sockets.*

### Installing

1. Slide the flip back armrest into the arm sockets on the wheelchair frame.
2. Install the quick release pin through the rear arm socket and flip back armrest.
3. Lock flip back armrest by pressing flip back armrest release lever into the locked position (FIGURE 6.1).
4. Lift Up on flip back armrest to make sure the armrest is locked in place.
5. Repeat STEPS 1-4 for opposite flip back armrest.

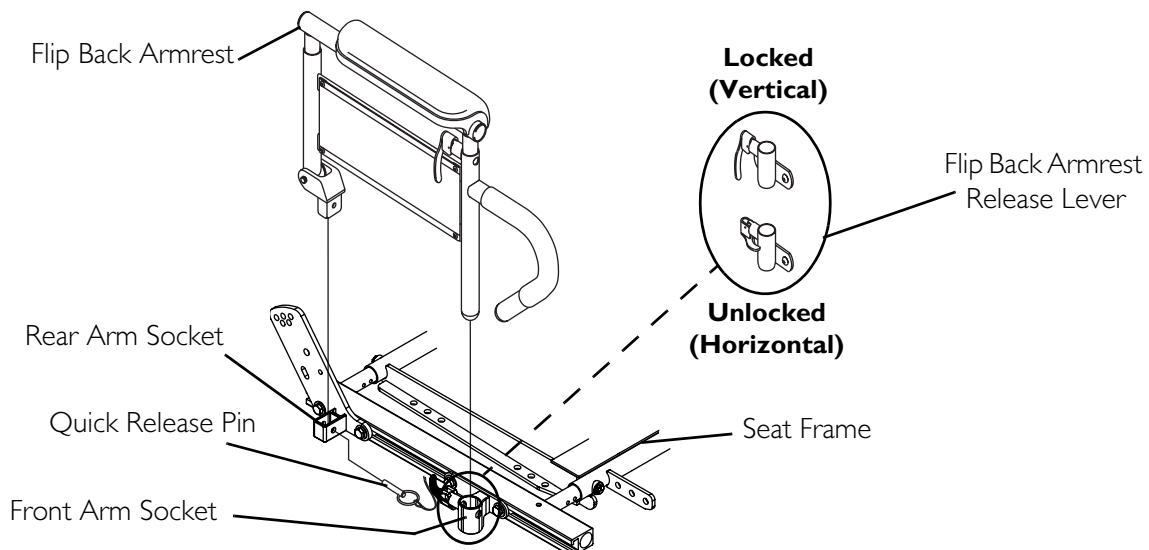

**FIGURE 6.1** Installing/Removing Flip Back Armrests

## Removing

1. Unlock flip back armrest by pulling flip back armrest release lever into the unlocked position (FIGURE 6.1).
2. Remove the quick release pin that secures the flip back armrest to the wheelchair frame.
3. Pull Up on the flip back armrest and remove the armrest from the arm sockets.
4. Repeat STEPS 1-3 for the opposite flip back armrest, if necessary.

## Adjusting Flip Back Armrests

*NOTE: For this procedure, refer to FIGURE 6.2.*

### Positioning Flip Back Armrests for User Transfer

1. Unlock the flip back armrest by pulling the armrest release lever into the unlocked (horizontal) position.
2. Pull Up on the flip back armrest and remove the armrest from the front arm socket.
3. Flip the armrest back until it is out of the way.
4. Repeat STEPS 1-3 for opposite flip back armrest, if necessary.

### Positioning Flip Back Armrests for Use

1. Ensure that the flip back armrest release lever is in the unlocked (horizontal) position.
2. Install the flip back armrest into the front arm socket.
3. Lock flip back armrest by pressing flip back armrest release lever into the locked (vertical) position.
4. Lift Up on flip back armrest to make sure the armrest is locked in place.
5. Repeat STEPS 1-4 for opposite flip back armrest, if necessary.

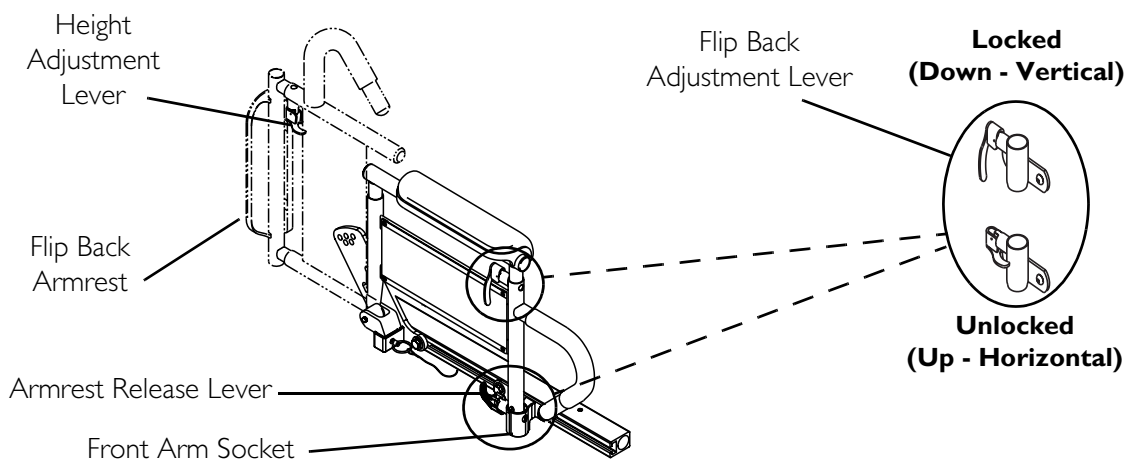

**FIGURE 6.2** Adjusting Flip Back Armrests

## Adjusting

1. Unlock top of flip back armrest by pulling height adjustment lever into the unlocked (horizontal) position.
2. Adjust top of the flip back armrest to the desired height.
3. Lock top of flip back armrest by pushing height adjustment lever into the locked (vertical) position.
4. Lift Up on flip back armrest to make sure the armrest is locked in place.
5. Repeat STEPS 1-4 for opposite flip back armrest, if necessary.

## Adjusting Van Seat Armrests

### Angle

*NOTE: For this procedure, refer to Detail "A" of FIGURE 6.3.*

1. Lift UP the armrest.
2. Loosen the jam nut.
3. Adjust the socket screw Up or Down to the desired arm angle position.
4. Tighten the jam nut.
5. To determine the same angle for the opposite armrest, count the exposed threads after the jam nut has been tightened.
6. Repeat STEPS 1-4 for opposite armrest, if necessary.

### Height

*NOTE: For this procedure, refer to Detail "B" of FIGURE 6.3.*

1. Remove the socket screw that secures the armrest to the seat frame assembly.
2. Adjust the armrest to one of four positions.
3. Reinstall the socket screw that secures the armrest to the seat frame assembly and tighten securely.

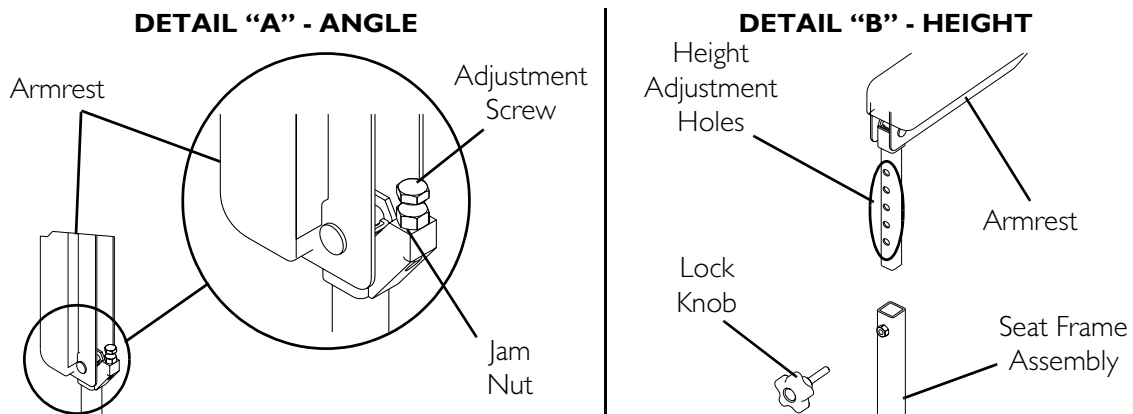

**FIGURE 6.3** Adjusting Van Seat Armrests

# SECTION 7—SEAT

## ⚠ WARNING

After **ANY** adjustments, repair or service and **BEFORE** use, make sure that all attaching hardware is tightened securely - otherwise injury or damage may result.

Before performing any maintenance, adjustment or service verify that **ON/OFF** switch on the joystick is in the **OFF** position.

## Adjusting the Headrest

*NOTE: For this procedure, refer to FIGURE 7.1.*

1. To raise headrest, lift headrest Up to desired position.

*NOTE: Headrest is locked in position when an audible “click” is heard.*

2. To lower headrest, push release tab towards the inside of the wheelchair. Lower headrest to desired position.

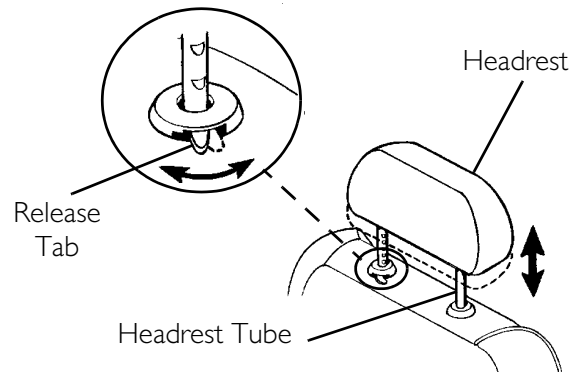

**FIGURE 7.1** Adjusting the Headrest

## Adjusting the Back Angle

### Van Seat Model

*NOTE: For this procedure, refer to FIGURE 7.2.*

1. Lift UP on the release handle and adjust seat to desired angle.
2. Let go of the release handle to lock the back in position.

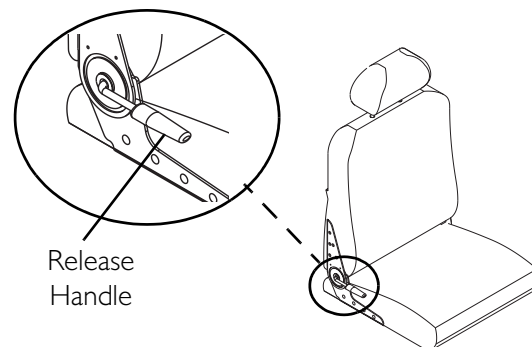

**FIGURE 7.2** Adjusting the Back Angle - Van Seat Model

### Adjustable Seat Back Angle (ASBA) Model

*NOTE: For this procedure, refer to FIGURE 7.3.*

1. Loosen, but **DO NOT** remove, the two lower hex screws securing the cane brackets to the back canes.

2. Remove the two upper hex screws, washers and locknuts securing the cane brackets to the back canes.
3. Align the upper mounting holes in the back canes with the desired mounting holes in the cane brackets (Detail "A" of FIGURE 7.3).
4. Install the two upper hex screws, washers and locknuts to secure the cane brackets to the back canes.
5. Torque the locknuts to 13 ft-lbs.

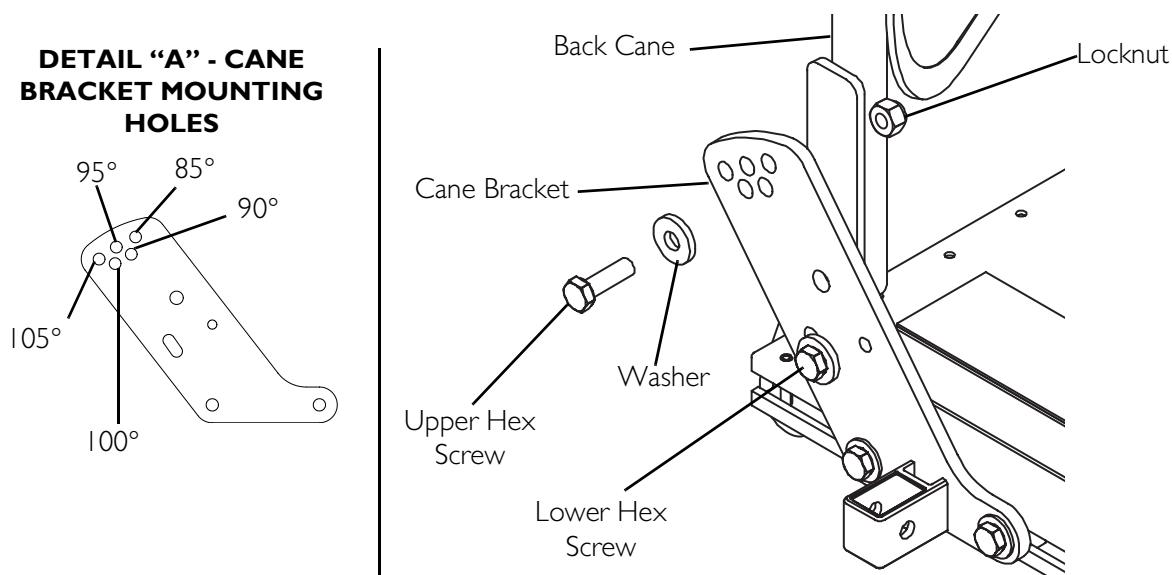

**FIGURE 7.3** Adjusting the Back Angle - Adjustable Seat Back Angle (ASBA) Model

## Removing/Installing the Seat Assembly

### **⚠ WARNING**

**DO NOT** store items under seat - interference with seat latch may result.

*NOTE: For this procedure, refer to FIGURE 7.4.*

*NOTE: This procedure is for wheelchairs WITHOUT the Formula PTO Plus seating system ONLY. For wheelchairs with the Formula PTO Plus seating system, refer to Tilting the Seat Assembly on page 63.*

### Removing

1. Disconnect the joystick. Refer to Disconnecting/Connecting the MK5 Joysticks on page 93.
2. Push Down on the latch bar underneath front of seat.
3. Tilt front edge of seat Up.
4. Slide the seat assembly forward to disengage seat from the pivot brackets located in the rear.



## Installing

1. Position the seat in the rear pivot brackets as shown in FIGURE 7.4.
2. Tilt front edge of seat Down.
3. When seat is lowered, engage seat brackets into seat clevis pins.

### **⚠ WARNING**

**When reinstalling the seat verify that the seat brackets are engaged with the seat clevis pins by pulling up on the latch bar.**

4. Pull UP on latch bar to verify that brackets are engaged with seat clevis pins.
5. Connect the joystick. Refer to Disconnecting/Connecting the MK5 Joysticks on page 93.

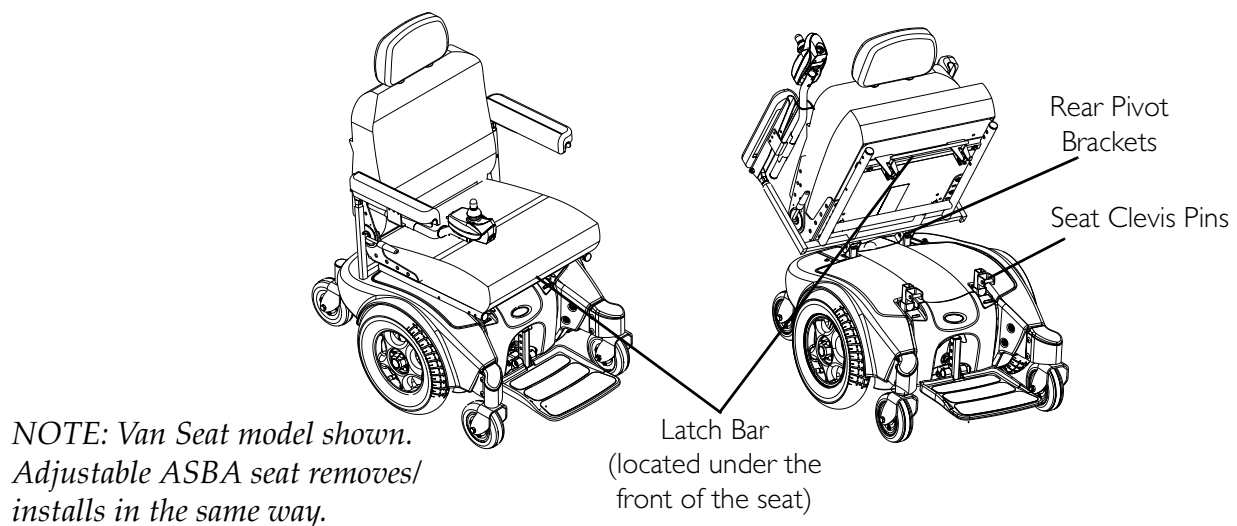

**FIGURE 7.4** Removing/Installing the Seat Assembly

## Adjusting the Seat Height

### **⚠ WARNING**

**Adjusting the seat height for wheelchairs with Formula PTO Plus cannot be achieved by following this procedure.**

*NOTE: For this procedure, refer to FIGURE 7.5.*

*NOTE: The seat can be adjusted to five height positions in ½-inch increments.*

1. Remove the seat. Refer to Removing/Installing the Seat Assembly on page 56.
2. Remove the mounting screw and locknut that secures the adjustable height tube to the support tube.

3. Adjust tube to desired mounting position. Refer to the following table for available mounting positions.

AVAILABLE MOUNTING HOLES FOR FRONT ADJUSTABLE HEIGHT TUBE					
WHEELCHAIR IS EQUIPPED WITH	A	B	C	D	E
<b>VAN SEAT WITH FOOTBOARD</b>					
REAR ADJUSTABLE HEIGHT TUBE					
Mounted in hole A	N/A**	✓	✓	✓	✓
Mounted in hole B	N/A*	N/A*	✓	✓	✓
Mounted in hole C	N/A*	N/A*	✓	✓	✓
Mounted in hole D	N/A*	N/A*	N/A*	✓	✓
Mounted in hole E	N/A*	N/A*	N/A*	N/A*	✓

\*NOTE: This mounting hole combination would result in a forward seat dump. Forward seat dump is where the rear of the seat is higher than the front of the seat. The seat should never be adjusted to a position that results in a forward seat dump.

\*\*NOTE: This mounting hole combination cannot be used because it would cause the front riggings of the wheelchair to interfere with other components of the wheelchair.

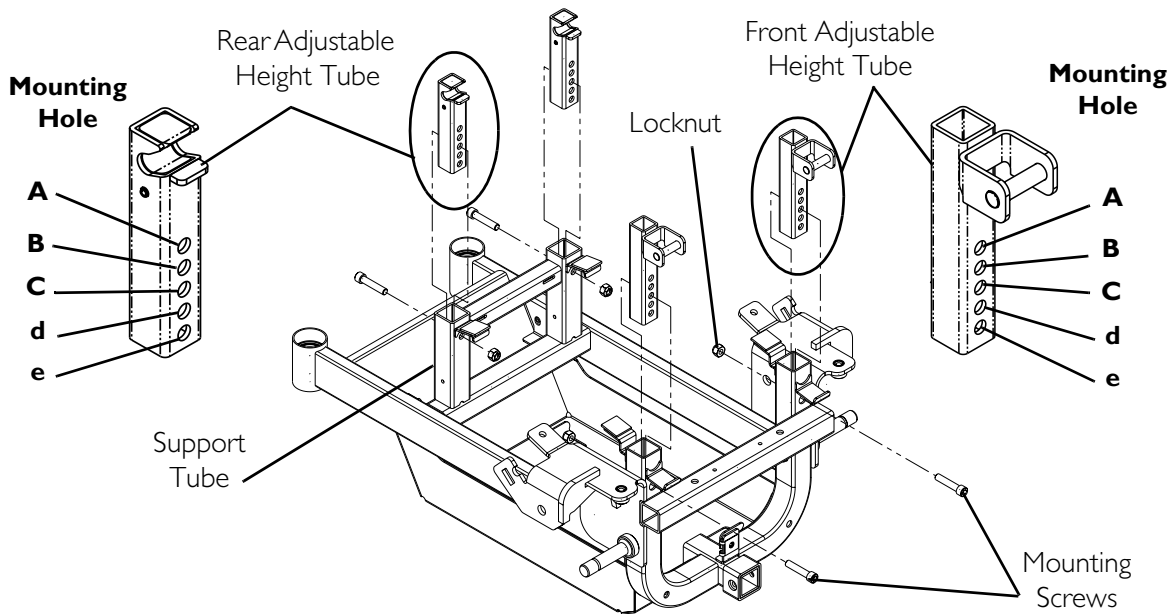

**FIGURE 7.5** Adjusting the Seat Height

4. Reinstall mounting screw and locknut (FIGURE 7.5). Securely tighten.  
5. Repeat STEPS 2-4 for the three remaining adjustable height tubes.

### **⚠ WARNING**

**When reinstalling the seat verify that the seat brackets are engaged with the seat clevis pins by pulling UP on the latch bar.**

6. Reinstall the seat. Refer to Removing/Installing the Seat Assembly on page 56.

# Adjusting Seat Position on Seat Frame

## Adjustable ASBA And Formula PTO Plus Models

### **⚠ WARNING**

**DO NOT** attempt to adjust the seat position of the Adjustable ASBA seat or the Formula PTO Plus seat on the seat frame. This procedure **MUST** be performed by a qualified technician.

### Van Seat Model

*NOTE: For this procedure, refer to FIGURE 7.6 and FIGURE 7.7.*

1. Remove the seat. Refer to Removing/Installing the Seat Assembly on page 56.
2. Remove the four mounting screws and washers securing the seat assembly to the seat frame (FIGURE 7.6).
3. Separate the seat assembly from the seat frame.

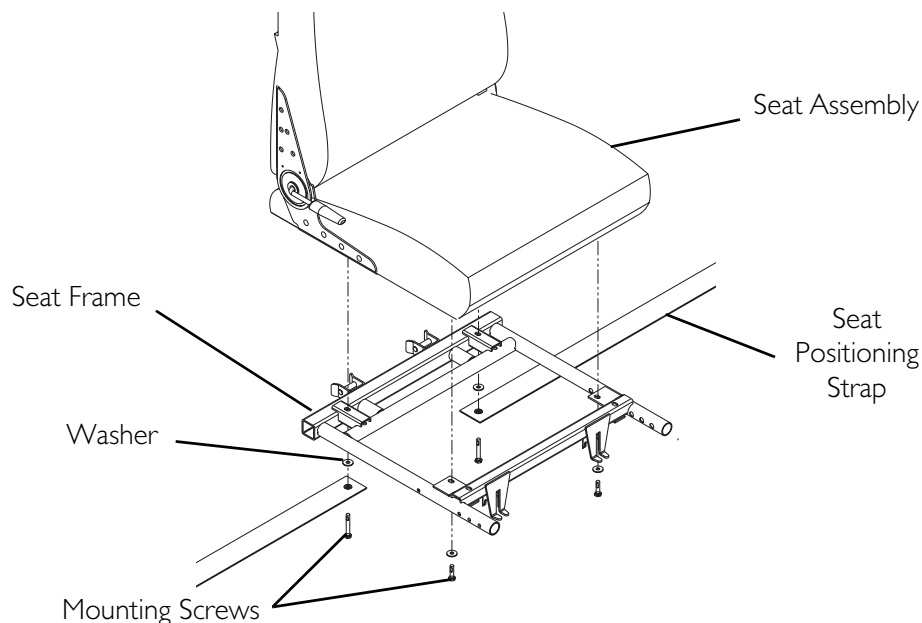

**FIGURE 7.6** Adjusting Seat Position on Seat Frame

4. Refer to FIGURE 7.7 to determine the correct mounting holes to achieve the desired seat position.
5. Align the seat assembly mounting holes determined in STEP 4 with the seat frame mounting holes determined in STEP 4.
6. Using the four mounting screws and washers, secure the seat assembly to the seat frame. Securely tighten.
7. Reinstall the seat. Refer to Removing/Installing the Seat Assembly on page 56.

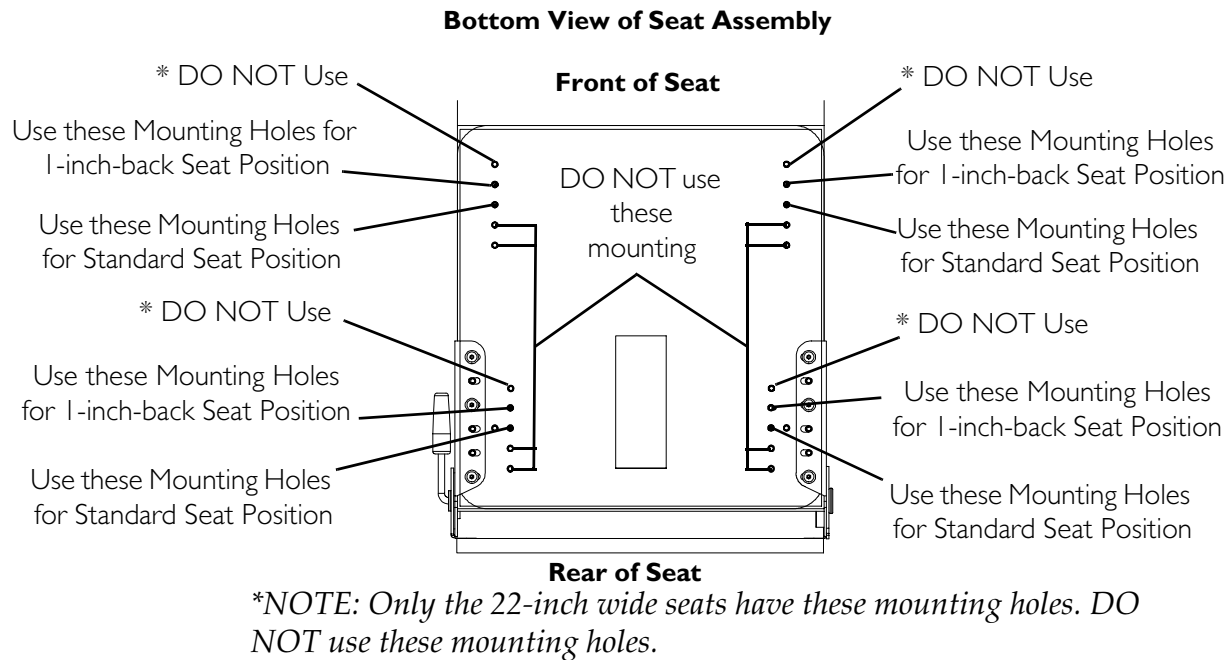

**FIGURE 7.7** Adjusting Seat Position on Seat Frame

## Adjusting Seat Depth - Van Seat Only

*NOTE: For this procedure, refer to FIGURE 7.8.*

1. Remove the seat. Refer to Removing/Installing the Seat Assembly on page 56.
2. Remove the seat base from the seat assembly. Refer to Adjusting Seat Position on Seat Frame on page 59.
3. Remove the six mounting screws located under the seat that secure the seat back assembly in place.
4. Adjust seat back assembly to desired position and reinstall the six mounting screws. Securely tighten.

*NOTE: Refer to Detail "A" of FIGURE 7.8 for proper seat depth positions. For example, to achieve maximum seat depth, the front mounting hole on the seat back bracket aligns with the third hole on the seat base.*

5. Reinstall the seat base onto the seat assembly. Refer to Adjusting Seat Position on Seat Frame on page 59.
6. Reinstall the seat. Refer to Removing/Installing the Seat Assembly on page 56.

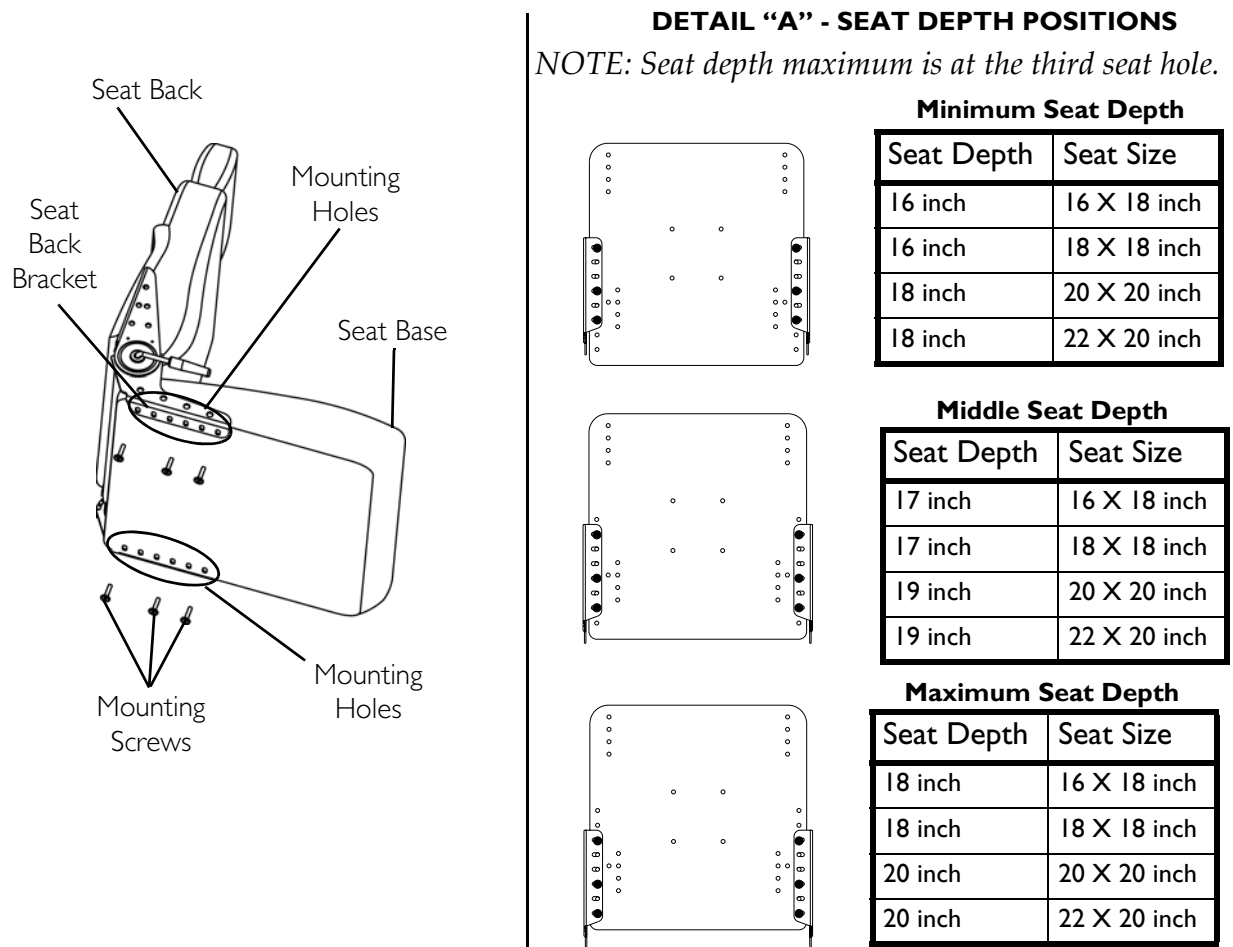

**FIGURE 7.8** Adjusting Seat Depth - Van Seat Only

## Replacing the Seat Positioning Strap

### ⚠ **WARNING**

**ALWAYS** wear your seat positioning strap.

The seat positioning strap is a positioning belt **ONLY**. It is not designed for use as a safety device withstanding high stress loads such as auto or aircraft safety belts. If signs of wear appear, belt must be replaced immediately.

### Wheelchairs with TRRO Option

To replace the seat positioning strap, refer to [Wheelchair-Anchored Belts](#) on page 99.

### Wheelchairs without TRRO Option

#### Adjustable ASBA and Formula PTO Plus Models

*NOTE: For this procedure, refer to FIGURE 7.9.*

1. Remove the two mounting screws and locknuts that secure the seat positioning straps to the seat frame.
2. Remove the two halves of the seat positioning strap from the rear seat frame.
3. Reposition the two new seat positioning strap halves to the seat frame.
4. Reinstall the two mounting screws and locknuts that secure the seat positioning straps to the seat frame and torque to 75 inch-pounds.

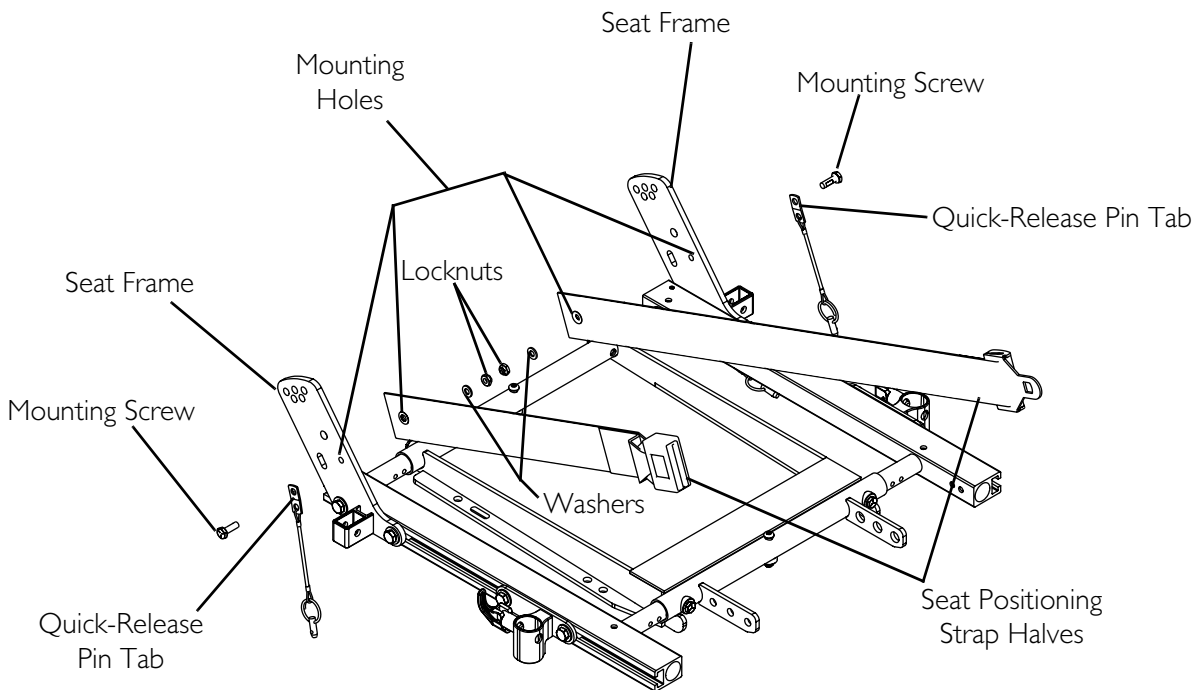
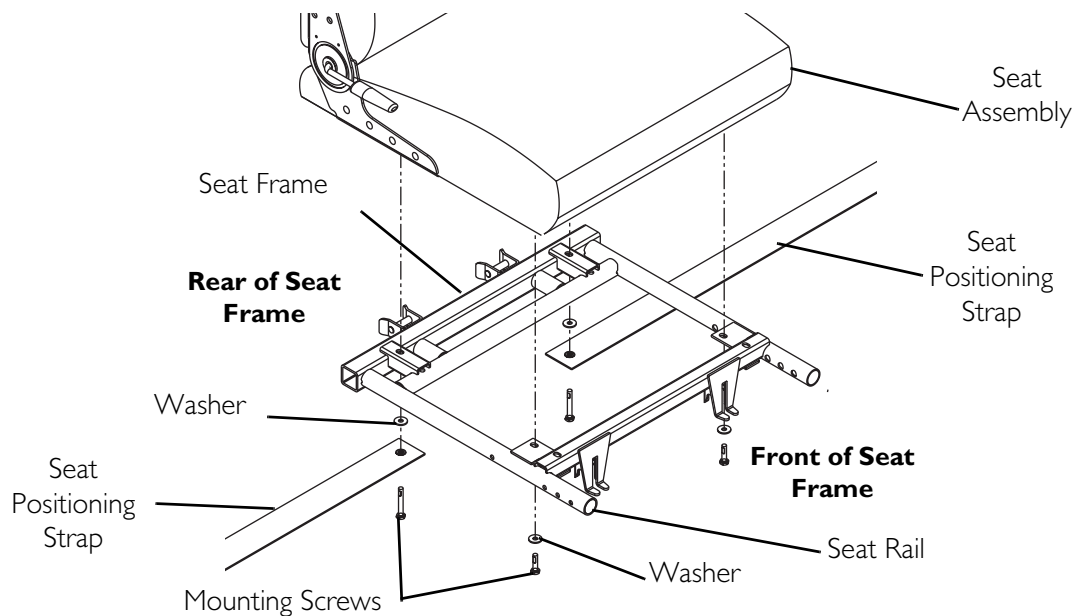

**FIGURE 7.9** Replacing the Seat Positioning Strap - Wheelchairs without TRRO Option - Adjustable ASBA and Formula PTO Plus Models

### Van Seat Model

*NOTE: For this procedure, refer to FIGURE 7.10.*

1. Remove the two mounting screws and washers that secure the seat positioning straps to the seat frame.
2. Remove the two halves of the seat positioning strap from the rear seat frame.
3. Reposition the two new seat positioning strap halves underneath seat rails.
4. Reinstall the two mounting screws and washers that secure the seat positioning straps to the seat frame. Securely tighten.



**FIGURE 7.10** Replacing the Seat Positioning Strap - Wheelchairs without TRRO Option - Van Seat Model

## Tilting the Seat Assembly

*NOTE: For this procedure, refer to FIGURE 7.11.*

*NOTE: This procedure is for M91 wheelchairs with the Formula PTO Plus Seating System ONLY.*

*NOTE: Removing the seat is not necessary to access the battery compartment on wheelchairs equipped with a Formula PTO Plus seating system. The seat assembly with the Formula PTO Plus seating system tilts back and props into place to provide access to the batteries and the underside of the seat.*

### **⚠ WARNING**

**Make sure power to the wheelchair is Off before performing this procedure.**

**Never leave the seat assembly in the Up/Open position unless necessary to perform a procedure on the wheelchair - otherwise injury or damage may result.**

**After ANY adjustments, repair or service and before use, make sure all attaching hardware is tightened securely - otherwise injury or damage may result.**

## Tilting the Seat Assembly Back

1. Place the wheelchair in a well ventilated area where work can be performed without risking damage to carpeting or floor covering.
2. Tilt seat back 20° to 25°. Refer to Operating the Formula PTO Plus System on page 40.
3. Verify the joystick On/Off switch is in the Off position and disconnect joystick cable.
4. Engage the motor release levers. Refer to Engaging/Disengaging Motor Release Lever on page 79.

5. Remove front rigging. Refer to Installing/Removing Front Riggings on page 63.
6. Remove the two screws and washers securing the Formula PTO Plus frame to the front seat posts.
7. Firmly grasp the front edge of the seat assembly, slowly tilt the seat assembly back into the Up/Open position.
8. Remove prop rod from the clip located on the Formula PTO Plus frame and engage the prop rod end into the front seat post as shown in FIGURE 7.11.
9. Gently allow weight of seat assembly to be supported by the prop rod.

*NOTE: Only leave the seat assembly in the Up/Open position while performing any necessary procedures. Always lower the seat assembly to the Down/Closed position when not servicing the wheelchair and ensure it is in the locked position before using.*

### Tilting the Seat Assembly Forward

1. Using one hand, firmly grasp the front edge of the seat assembly and lift until seat assembly is no longer supported by the prop rod.
2. Disengage the prop rod from the front seat post and secure into clip.
3. Using both hands, slowly tilt the seat assembly Forward into the Down/Closed position.

---

### **⚠ WARNING**

**Ensure the two screws are fully engaged and the Formula PTO Plus frame is securely locked in place before use - otherwise injury or damage may result.**

---

4. Insert the two screws through the washers, the Formula PTO Plus frame and the two front seat posts.

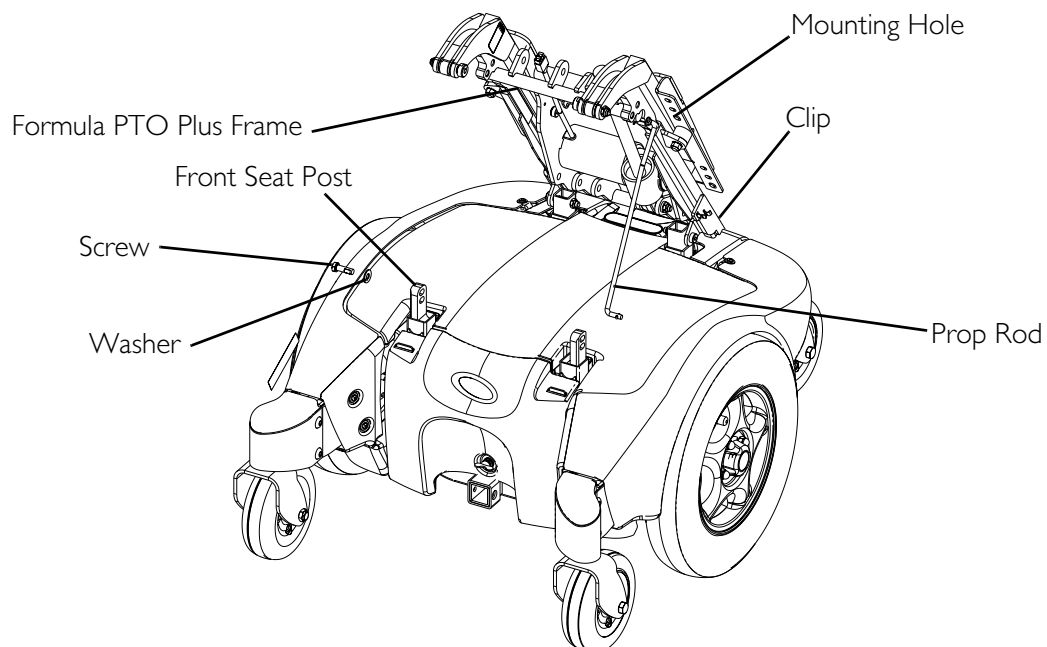

**FIGURE 7.11** Tilting the Seat Assembly



---

# SECTION 8—FOOTBOARD ASSEMBLY

---

## **⚠ WARNING**

After **ANY** adjustments, repair or service and **BEFORE** use, make sure that all attaching hardware is tightened securely - otherwise injury or damage may result.

Before performing any maintenance, adjustment or service verify that **ON/OFF** switch on the joystick is in the **OFF** position.

**DO NOT** stand on the flip-up footboard. When getting in or out of the wheelchair, make sure that the flip-up footboard is in the upward position.

**LIMITED CLEARANCE BETWEEN FOOTBOARD AND CASTER** - The user's feet **MUST** remain on the footboard while operating the wheelchair. If the user's feet are allowed to rest off the side of the footboard they may come in contact with the caster possibly resulting in injury.

---

## Removing/Installing the Footboard Assembly

*NOTE: For this procedure, refer to FIGURE 8.1.*

### Removing

1. Remove the quick release pin that secures the footboard assembly to the wheelchair frame by depressing the button while sliding the pin out.
2. Remove the footboard assembly from the wheelchair frame.

### Installing

---

## **⚠ WARNING**

**Make sure the detent balls of the quick release pin are fully released and protruding past the outer edge of the tube before operating the wheelchair. Otherwise, injury and/or damage may result.**

**Keep detent balls clean.**

---

1. Position the footboard assembly onto the wheelchair frame so that the mounting hole in the wheelchair frame aligns with the desired mounting hole in the footboard assembly.
2. Install the quick release pin by depressing the button while sliding the pin in. Ensure that the detent balls of the quick release pin are fully released and protruding past the outer edge of the tube (Detail "A" of FIGURE 8.1).

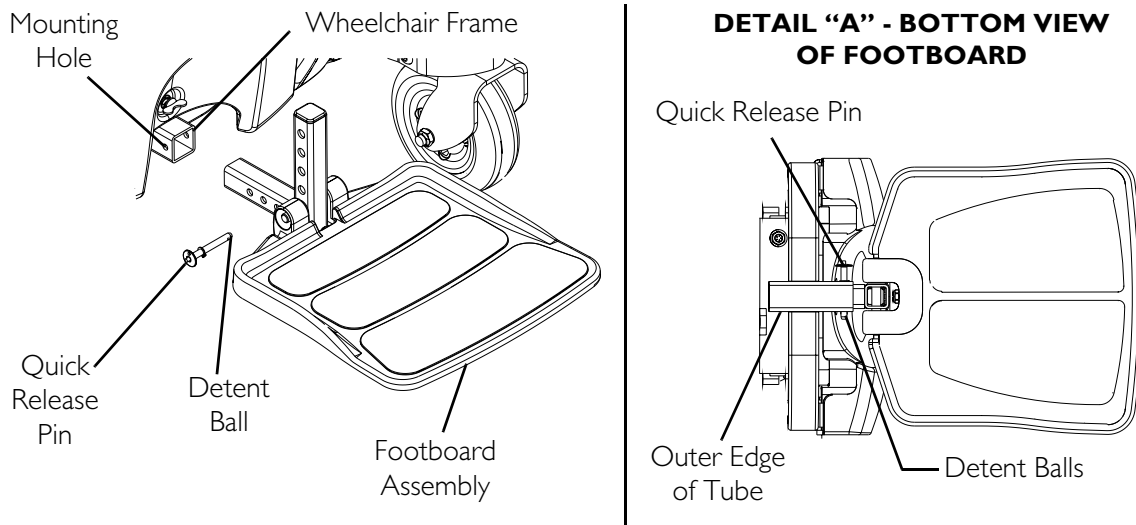

**FIGURE 8.1** Removing/Installing the Footboard Assembly

## Adjusting the Footboard Assembly

### Angle

*NOTE: For this procedure, refer to FIGURE 8.2.*

1. Loosen the jam nut and set screw located underneath on the back of the footplate.
2. Adjust the set screw in or out to obtain the desired footboard assembly angle.
3. Thread the jam nut and washer inward until it is flush with the footboard bracket.
4. Securely tighten the jam nut and washer to secure the mounting screw in place.

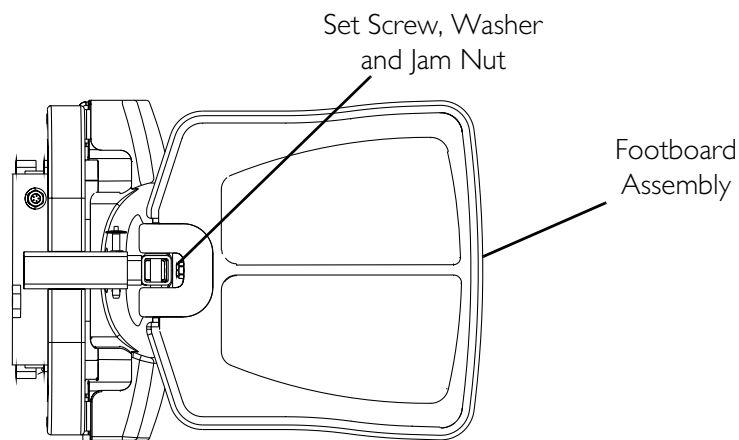

**FIGURE 8.2** Adjusting the Footboard Assembly - Angle

## Depth

*NOTE: For this procedure, refer to FIGURE 8.3.*

1. Remove the quick release pin that secures the footboard assembly to the wheelchair frame.

### **⚠ WARNING**

**Make sure the detent balls of the quick release pin are fully released and protruding past the outer edge of the tube before operating the wheelchair. Otherwise, injury and/or damage may result.**

**Keep detent balls clean.**

2. Adjust footboard to one of three mounting positions.
3. Install the quick release pin. Make sure the detent balls of the quick release pin are fully released and past the outer edge of the tube (Detail “A” of FIGURE 8.3).

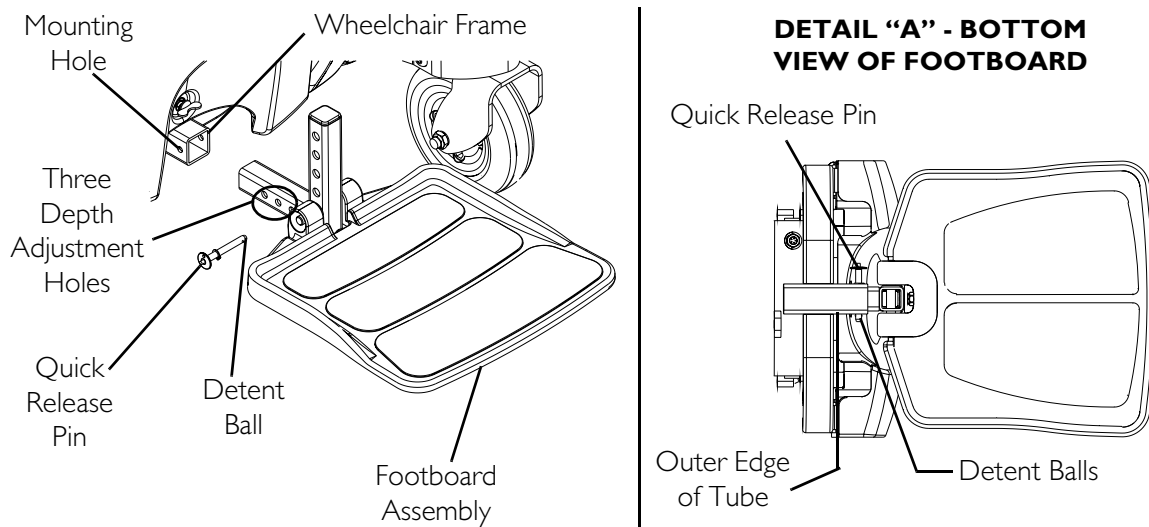

**FIGURE 8.3** Adjusting the Footboard Assembly - Depth

# SECTION 9—FRONT RIGGINGS

## ⚠ WARNING

After **ANY** adjustments, repair or service and **BEFORE** use, make sure that all attaching hardware is tightened securely - otherwise injury or damage may result.

**DO NOT** stand on the front riggings, otherwise damage may occur. When getting in or out of the wheelchair, make sure that the footplates on the front riggings are in the upward position or moved out of the way.

Before performing any maintenance, adjustment or service verify that **On/Off** switch on the joystick is in the **OFF** position.

## Installing/Removing Front Riggings

### CAUTION

If front riggings are used, then the seat **MUST** be adjusted to the highest mounting position - otherwise damage may occur.

*NOTE: For this procedure, refer to FIGURE 9.1.*

### Installing

1. If necessary, remove the footboard.  
Refer to [Removing/Installing the Footboard Assembly](#) on page 65.
2. Turn front rigging to the side (open footplate is perpendicular to wheelchair) and position mounting holes in the front rigging hinge plates with hinge pins on the wheelchair frame.
3. Install the front rigging hinge plates onto the hinge pins on the wheelchair frame.
4. Push the front rigging towards the inside of the wheelchair until it locks into place.  
*NOTE: The footplate will be on the inside of the wheelchair when locked in place.*
5. Repeat STEPS 1-4 for opposite side of wheelchair.

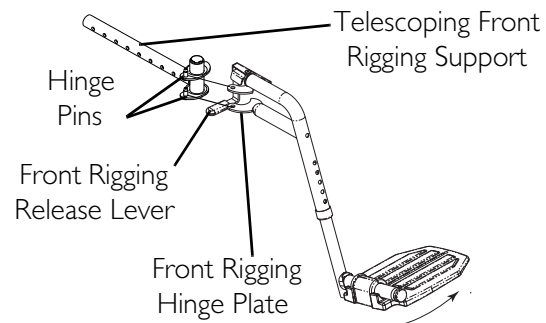

**FIGURE 9.1** Installing/Removing Front Riggings

### Removing

1. Push the front rigging release lever inward and rotate the footrest out.
2. Lift up on front rigging and remove from the wheelchair.
3. Repeat STEPS 1-2 for opposite side of wheelchair.

## Adjusting Footrest Height

### Model PHWH93

*NOTE: For this procedure, refer to FIGURE 9.2.*

1. Remove any accessories from the footrest(s).
2. Remove the footrest from the wheelchair. Refer to [Installing/Removing Front Riggings](#) on page 68.

*NOTE: Lay footrest on a flat surface to simplify section.*

3. Remove the hex bolt, coved washers and locknut that secure the lower footrest to the footrest support.
4. Reposition the lower footrest to the desired height.
5. Reinstall hex bolt, coved washers and locknut that secure lower footrest to footrest support. Tighten securely.
6. Repeat STEPS 1-5 for the opposite side of the wheelchair footrest, if necessary.
7. Reinstall the footrest(s) onto the wheelchair. Refer to [Installing/Removing Front Riggings](#) on page 68.
8. Reinstall any accessories onto the footrest(s).

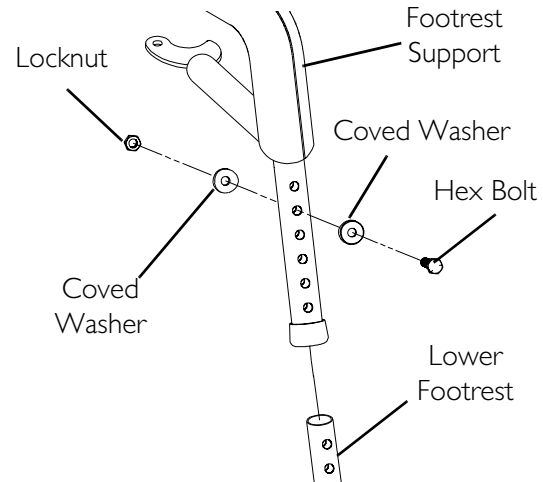

**FIGURE 9.2** Adjusting Footrest Height - Model PHWH93

### Model PH904A and PHAL4A

*NOTE: For this procedure, refer to FIGURE 9.3.*

*NOTE: PH904A style front rigging shown. PHAL4A front rigging adjust the same way.*

1. Loosen, but do not remove the lug bolt and locknut that secure the lower footrest to the footrest support.
2. Reposition the lower footrest to the desired height.
3. Securely tighten the lug bolt and locknut that secure the lower footrest to the footrest support.
4. Repeat STEPS 1-3 for the opposite side of the wheelchair footrest, if necessary.

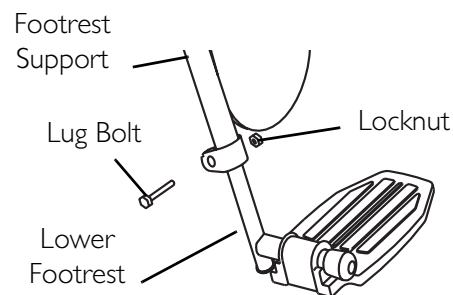

**FIGURE 9.3** Adjusting Footrest Height - Model PH904A and PHAL4A

## Replacing Heel Loops

*NOTE: For this procedure, refer to FIGURE 9.4.*

1. Note the position of hex bolt, covered washers and locknut for reinstallation.
2. Remove the hex bolt, covered washers and locknut that secure the lower footrest to the footrest support.
3. Remove the lower footrest.
4. Remove the phillips bolt, spacer and locknut that secure the existing heel loop to the lower footrest.
5. Slide the existing heel loop off the lower footrest.
6. Replace heel loop.
7. Reverse STEPS 1-6 to reassemble.

*NOTE: When securing heel loop to lower footrest, tighten the phillips screw and locknut until the spacer is secure.*

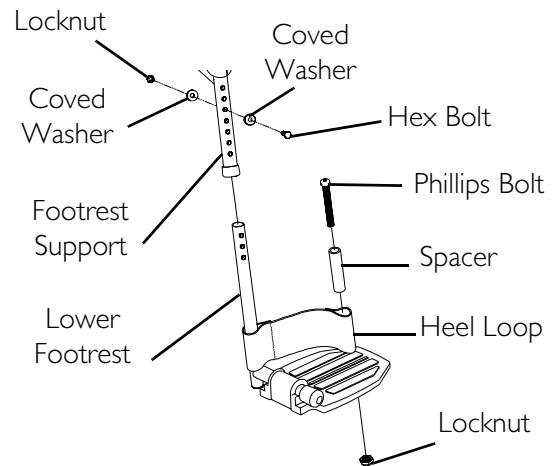
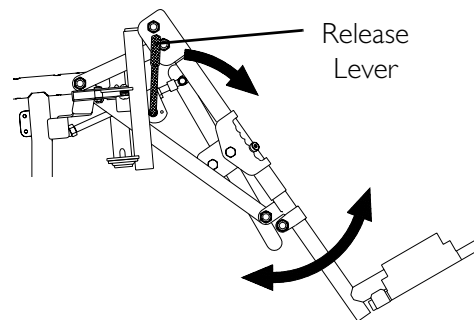

**FIGURE 9.4** Replacing Heel Loops

## Raising/Lowering Elevating Front Riggings

*NOTE: For this procedure, refer to FIGURE 9.5.*

1. Perform one of the following:
  - A. **RAISING** - Pull back on the release lever and raise front rigging to the desired height.
  - B. **LOWERING** - Support front rigging with one hand away from the release lever. Push release lever downward with other hand.



**FIGURE 9.5** Raising/Lowering Elevating Front Riggings

## Adjusting/Replacing Telescoping Front Rigging Supports - Van Style Seats

*NOTE: For this procedure, refer to FIGURE 9.6.*

*NOTE: When adjusting the telescoping front rigging support depth, ensure the footplate does not interfere with the caster wheel rotation.*

*NOTE: Telescoping front rigging supports may be extended up to 2-inches from the wheelchair frame in 1-inch increments. This adjustment does not affect seat depth.*

*NOTE: When installing the front riggings support tubes, ensure that the hinge pins are on the outside of the wheelchair facing away from the seat frame.*

1. Remove the seat. Refer to Removing/Installing the Seat Assembly on page 56.
2. Remove the two socket bolts and locknuts that secure telescoping front rigging support to the seat frame.
3. Perform one of the following:
  - A. **ADJUSTING** - Align the appropriate mounting hole of the telescoping front rigging support with the front mounting hole in the seat frame tubes to achieve the desired depth as shown in FIGURE 9.6.
  - B. **REPLACING** - Perform the following steps:
    - i. Remove the existing telescoping front rigging support from the wheelchair frame.
    - ii. Insert the new telescoping front rigging support into the seat frame.
    - iii. Align the appropriate mounting hole of the telescoping front rigging support with the front mounting hole in the seat frame tubes to achieve the desired depth as shown in FIGURE 9.6.

*NOTE: The footplate will be on the inside of the wheelchair when locked in place.*

4. Using the two socket bolts and locknuts, secure the telescoping front rigging support to the seat frame as shown in FIGURE 9.6.
5. If necessary, repeat STEPS 2-4 on remaining telescoping front rigging support.
6. Reinstall the seat. Refer to Removing/Installing the Seat Assembly on page 56.

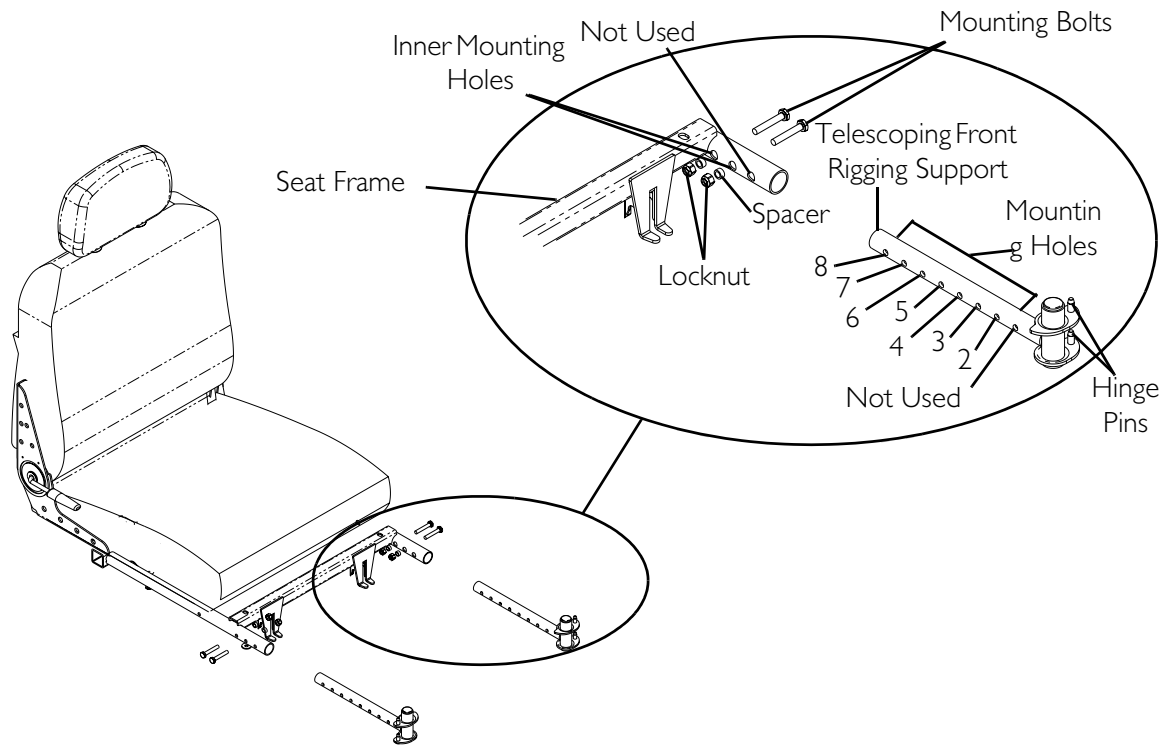

STANDARD POSITION			1 INCH OUT			2 INCHES OUT		
18 inches wide	20 inches wide	22 inches wide	18 inches wide	20 inches wide	22 inches wide	18 inches wide	20 inches wide	22 inches wide
Holes 2 and 3	Holes 2 and 3	Holes 3 and 4	Holes 3 and 4	Holes 3 and 4	Holes 5 and 6	Holes 4 and 5	Holes 4 and 5	Holes 6 and 7

**FIGURE 9.6** Adjusting/Replacing Telescoping Front Rigging Supports - Van Style Seats

## Adjusting/Replacing Telescoping Front Rigging Support

*NOTE: For this procedure, refer to FIGURE 9.7.*

1. Remove the two cap screws, spacers and threaded blocks securing the telescoping front tube to the side rail.
2. Perform one of the following:
  - Slide existing telescoping front rigging support to one of six depth positions.
  - Remove existing telescoping front rigging.
3. Secure the telescoping front tube to the side rail at the desired depth with the existing two cap screws, spacers and threaded blocks. Torque cap screws to 79 in-lbs.
4. Repeat STEPS 1 to 3 on the opposite side, if desired.

*NOTE: The two telescoping front rigging supports can be positioned at different depths depending on the need of the user.*



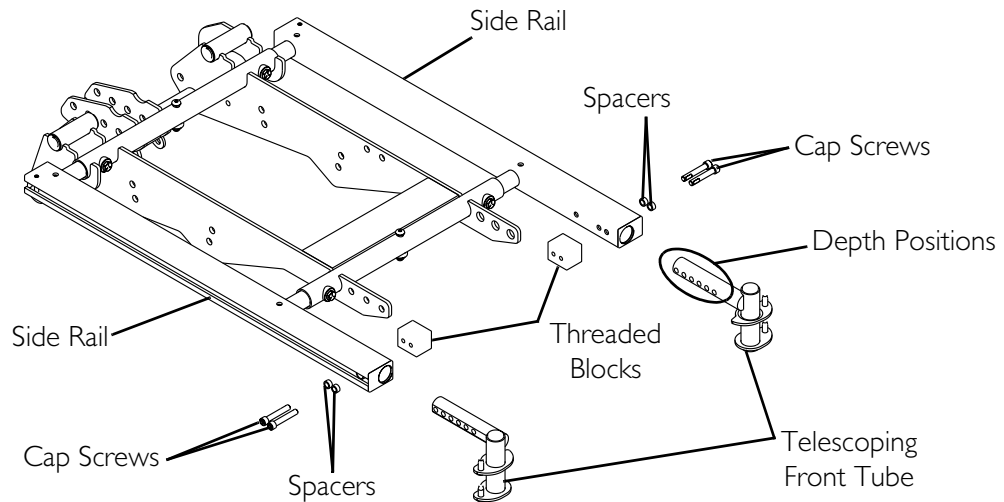

**FIGURE 9.7** Adjusting/Replacing Telescoping Front Rigging Support

## Removing/Installing the Center Mount Footrest

*NOTE: For this procedure, refer to FIGURE 9.8.*

### Removing

1. Remove the rigging pivot pin that secures the footrest to the mounting bracket of the seat frame.
2. Hold the footrest with one hand and engage the release lever with the other while simultaneously pulling the center mount footrest out of the mounting bracket of the seat frame.

### Installing

1. Engage the release lever with one hand, hold the center mount footrest with the other, and insert the center mount footrest into the mounting bracket of the seat frame.
2. Reinstall the rigging pivot pin to secure the center mount footrest to the mounting bracket of the seat frame.

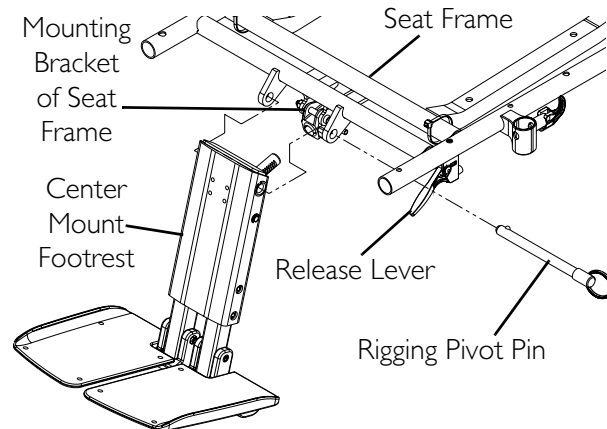

**FIGURE 9.8** Removing/Installing the Center Mount Footrest

## Adjusting the Height of the Center Mount Footrest

*NOTE: For this procedure, refer to FIGURE 9.9.*

### **⚠ WARNING**

**After adjusting the Center Mount Footrest, minimum ground clearance for the footrest in the driving position is 3 inches. If the Center Mount Footrest is in the retracted position and the wheelchair is not moving, the footrest must maintain a minimum of 1 inch ground clearance - otherwise personal injury and damage may result.**

1. Remove the two mounting screws that secure the footrest extension tube to the extension tube housing.
2. Adjust the footrest extension tube to the desired height and align the corresponding holes to the mounting holes on the extension tube housing.
3. Reinstall the two mounting screws to secure the footrest extension tube to the extension tube housing. Securely tighten.
4. Repeat STEPS 1-3 for the other extension tube.

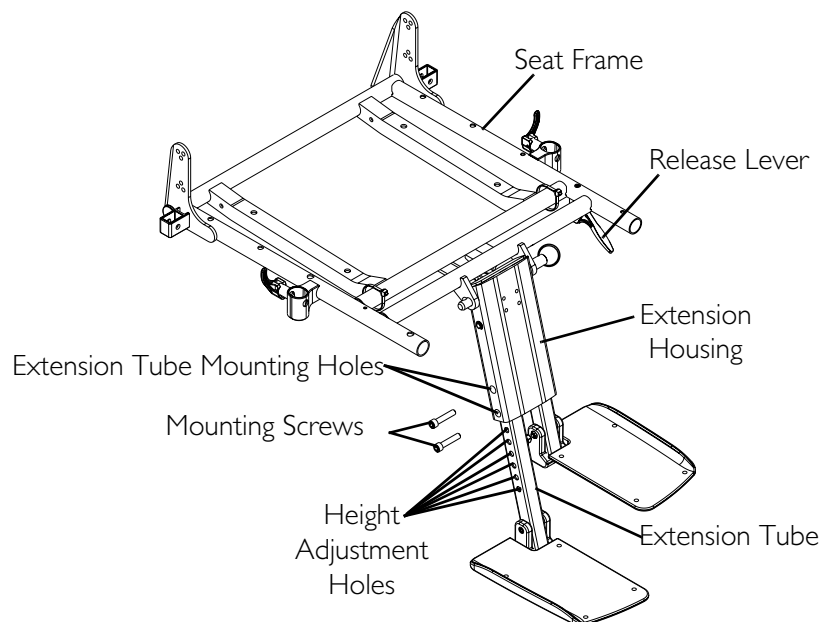

**FIGURE 9.9** Adjusting the Height of the Center Mount Footrest

## Adjusting the Angle of the Center Mount Footrest

*NOTE: For this procedure, refer to FIGURE 9.9 and FIGURE 9.10.*

### **⚠ WARNING**

**After adjusting the Center Mount Footrest, minimum ground clearance for the footrest in the driving position is 3 inches. If the Center Mount Footrest is in the retracted position and the wheelchair is not moving, the footrest must maintain a minimum of 1 inch ground clearance - otherwise personal injury and damage may result.**

1. Engage the release lever with one hand (not shown) and move the center mount footrest to the desired angle with the other hand.

*NOTE: Refer to FIGURE 9.9 for the location of the release lever.*

2. Disengage the release lever (not shown) to lock the center mount footrest in the new position.

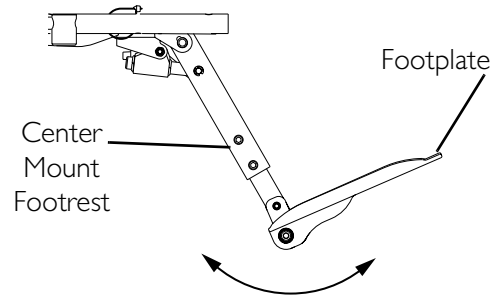

**FIGURE 9.10** Adjusting the Angle of the Center Mount Footrest

## Adjusting the Footplate Angle

*NOTE: For this procedure, refer to FIGURE 9.11.*

1. Loosen the footplate mounting screw and move the footplate to the desired angle.

*NOTE: DO NOT remove the footplate mounting screw.*

2. Tighten the footplate mounting screw to secure the footplate in the desired position.
3. Repeat STEPS 1 and 2 for the other footplate.

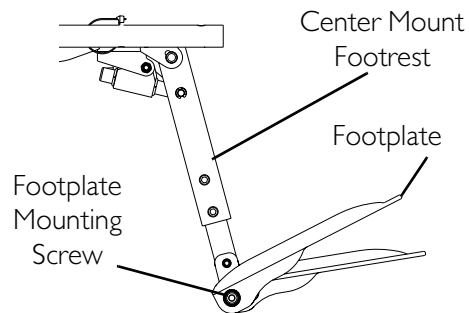

**FIGURE 9.11** Adjusting the Footplate Angle

## Adjusting the Tension of the Flip Up Footplate

*NOTE: For this procedure, refer to FIGURE 9.12.*

*NOTE: This procedure applies to both power and manual center mount footrests.*

*NOTE: The tension can be adjusted to increase or decrease the rotation effort of the flip up footplates.*

1. Loosen the mounting screw on the footrest angle hinge to decrease the rotation effort.

*NOTE: DO NOT remove the footplate mounting screw.*

2. Tighten the footrest angle hinge mounting screw to increase the rotation effort.

3. Repeat STEPS 1 and 2 for the other footplate.

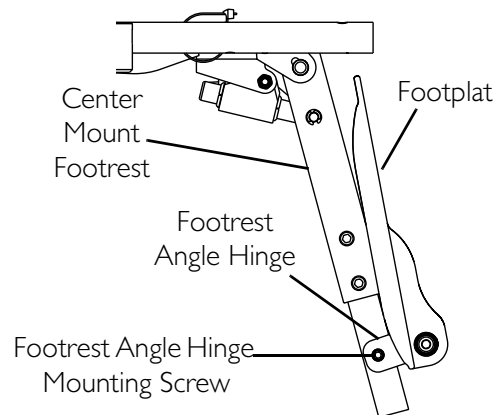

**FIGURE 9.12** Adjusting the Tension of the Flip Up Footplate

---

# SECTION 10—SHROUD/WHEELS

---

## **⚠ WARNING**

After **ANY** adjustments, repair or service and **BEFORE** use, make sure that all attaching hardware is tightened securely - otherwise injury or damage may result.

Before performing any maintenance, adjustment or service verify that **ON/OFF** switch on the joystick is in the **OFF** position.

---

## Replacing the Flat Free Tires on the Wheel Rim

---

### **⚠ WARNING**

**DO NOT** attempt to replace flat free tires. This procedure **MUST** be performed by a qualified technician.

---

*NOTE: During initial use of the wheelchair, the user may experience flat spots on the wheels. Flat spots will vanish with continued use of the wheelchair.*

## Removing/Installing the Shrouds

*NOTE: For this procedure, refer to FIGURE 10.1.*

### Removing

1. Perform one of the following:
  - A. Wheelchairs with Formula PTO Plus - Tilt the seat back. Refer to Tilting the Seat Assembly on page 63.
  - B. Wheelchairs without Formula PTO Plus - Remove the seat assembly. Refer to Removing/Installing the Seat Assembly on page 56.
2. Perform one of the following:
  - A. Top Shroud - Lift UP on rear edge of top shroud to release the four hook and loop strips that secure the top shroud to the base frame as shown in Detail "A" of FIGURE 10.1.
  - B. Front Shroud - Turn release knob ¼-turn to the unlocked position and lift UP to remove front shroud from base frame hooks as shown in Detail "B" in FIGURE 10.1.

## Installing

1. Perform one of the following:
  - A. Top Shroud - Position top shroud on to the base frame and gently press down on top shroud to secure the four hook and loop strips that secure the top shroud to the base frame as shown in Detail "A" of FIGURE 10.1.
  - B. Front Shroud - Position front shroud onto the two base frame hooks. Turn release knob  $\frac{1}{4}$ -turn to the locked position as shown in Detail "B" of FIGURE 10.1.
2. Perform one of the following:
  - A. Wheelchairs with Formula PTO Plus - Tilt the seat forward. Refer to Tilting the Seat Assembly on page 63.
  - B. Wheelchairs without Formula PTO Plus - Reinstall the seat. Refer to Removing/Installing the Seat Assembly on page 56.

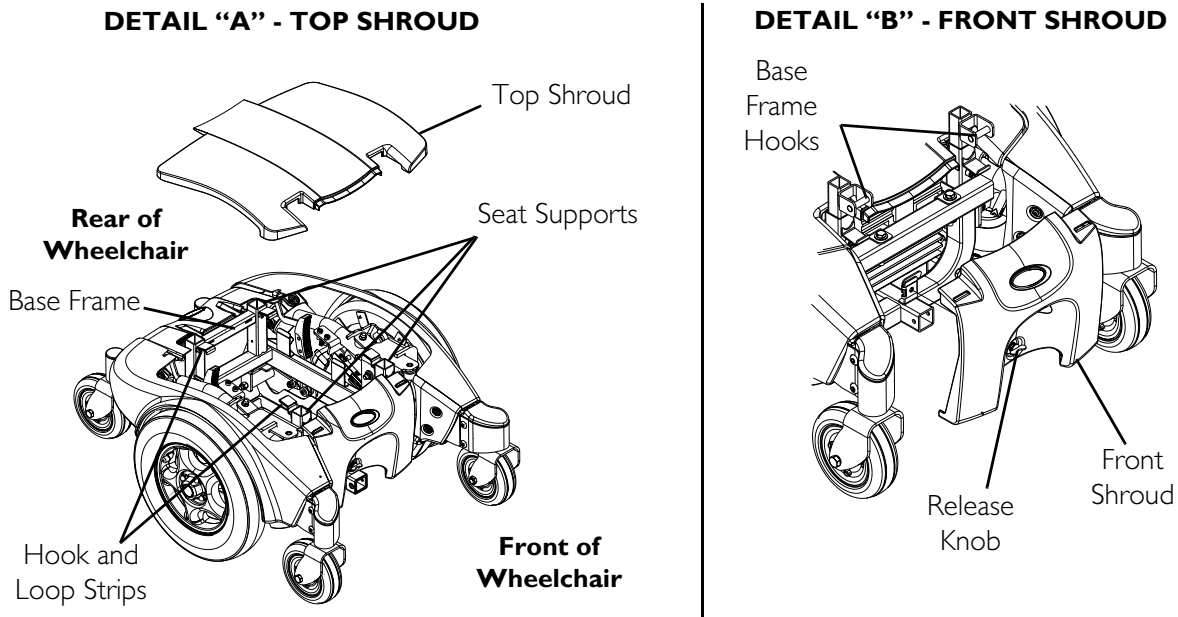

**FIGURE 10.1** Removing/Installing the Shrouds

## Engaging/Disengaging Motor Release Lever

### ⚠ WARNING

**DO NOT** engage or disengage the motor release lever until the **On/Off** switch on the joystick is in the **OFF** position.

### CAUTION

**Ensure both motor release levers are fully engaged BEFORE driving the wheelchair**

*NOTE: For this procedure, refer to FIGURE 10.2.*

*NOTE: The motor lock disengagement/engagement allows freewheeling OR joystick controlled operation. Freewheeling allows an attendant to maneuver the wheelchair WITHOUT power.*

1. Locate the motor release handles on the motors protruding through the shrouds by the rear springs.
2. Perform one of the following:
  - A. To disengage the motor release levers - Slide the motor lock lever towards the outside of the wheelchair (free wheel position) as shown in Detail "A" of FIGURE 10.2.

*NOTE: This allows the wheelchair to freewheel for pushing if necessary*

- B. To engage the motor release levers - Slide the motor lock handles towards the center of the wheelchair (drive position) as shown in Detail "A" of FIGURE 10.2.

*NOTE: This allows the motors to drive the wheels.*

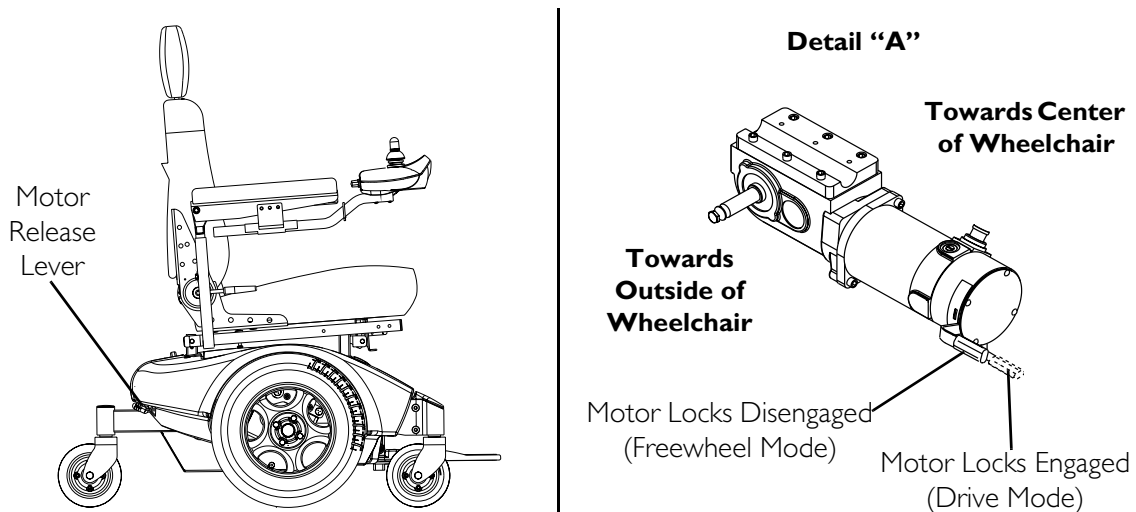

**FIGURE 10.2** Engaging/Disengaging Motor Release Lever

## Replacing Front/Rear Caster Assemblies

*NOTE: For this procedure, refer to FIGURE 10.3.*

*NOTE: Front and rear caster assemblies are replaced in the same manner.*

*NOTE: When replacing the front/rear caster assemblies, it is necessary to brace the caster assemblies to prevent the wheel from spinning.*

1. Remove the mounting screw, two washers, and locknut that secures the caster to the fork.
2. Remove the caster and discard.
3. Secure new caster to fork with existing mounting screw, two washers and locknut (FIGURE 10.3). Securely tighten.

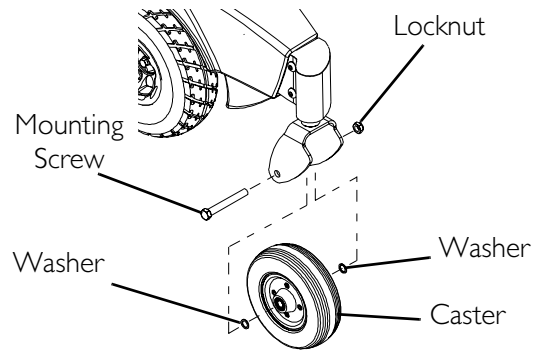
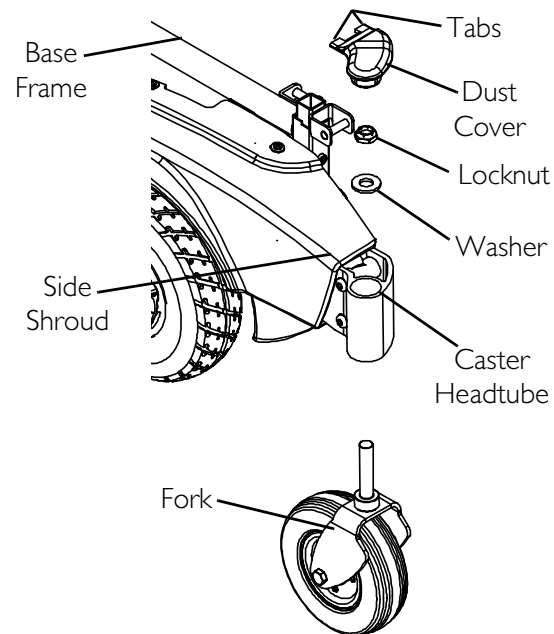

**FIGURE 10.3** Replacing Front/Rear Caster Assemblies

## Adjusting Forks

*NOTE: For this procedure, refer to FIGURE 10.4.*

1. Remove the dust cover.
2. To properly tighten caster journal system and guard against flutter, perform the following check:
  - A. Tip back the wheelchair.
  - B. Pivot both forks and casters to top of their arc simultaneously.
  - C. Let casters drop to bottom of arc (wheels should swing once to one-side, then immediately rest in a straight downward position).
  - D. Adjust locknuts according to freedom of caster swing.
3. Test wheelchair for maneuverability.
4. Readjust locknuts if necessary, and repeat STEPS 1-3 until correct.



**FIGURE 10.4** Adjusting Forks

5. Snap dust cover into the caster headtube ensuring that the tabs are under the plastic side shrouds.

*NOTE: Components exploded for clarity. There is no need to remove the fork from the base frame.*



# SECTION 11—BATTERIES

## ⚠ WARNING

Make sure power to the wheelchair is **OFF** before performing this section.

**NEVER** allow any of your tools and/or battery cable(s) to contact **BOTH** battery terminal(s)/post(s) at the same time. An electrical short may occur and serious personal injury or damage may occur.

The use of rubber gloves is recommended when working with batteries.

Always use a battery lifting strap when lifting a battery. It is the most convenient method and assures that the battery acid will not spill. It also helps to prolong the life of the battery.

**DO NOT** tip the batteries. Keep the batteries in an upright position.

Invacare strongly recommends that battery installation and battery replacement always be done by a qualified technician.

After **ANY** adjustments, repair or service and **BEFORE** use, make sure all attaching hardware is tightened securely - otherwise injury or damage may result.

Battery terminal configuration shown below **MUST** be used. Batteries that have the reversed terminal configuration **MUST NOT** be used - otherwise serious injury or damage may occur.

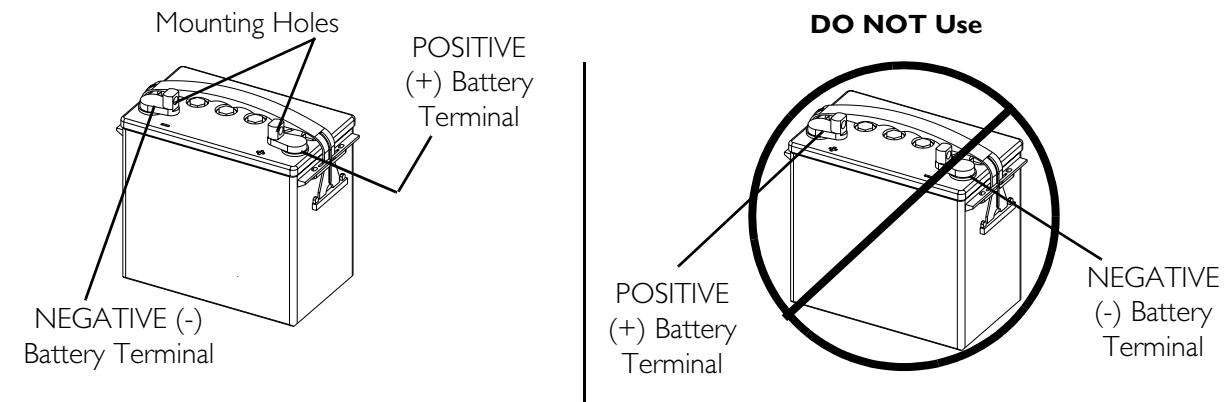

## CAUTION

When connecting the battery cables to the battery(ies), the battery cable(s) **MUST** be connected to the battery terminal(s)/post(s) as shown in **FIGURE 11.3** otherwise damage to the battery may result.

For proper battery connection, batteries **MUST** use post style terminals with mounting holes through the terminal.

*NOTE: If there is battery acid in the bottom of the battery tray or on the sides of the battery(ies), apply baking soda to these areas to neutralize the battery acid. Before reinstalling the existing or new battery(ies), clean the baking soda from the battery tray or battery(ies) being sure to avoid contact with skin and eyes. Determine source of contamination. Never install/reinstall a battery with a cracked or otherwise damaged case.*

## Installing/Removing the Batteries

NOTE: For this procedure, refer to FIGURE 11.1 and FIGURE 11.2.

NOTE: Have the following tools available:

TOOL	QTY	COMMENTS
Battery Lifting Strap	1	Supplied
1/2-inch (6 pt) Box Wrench	1	Not Supplied
7/16-inch (6pt) Box Wrench	1	Not Supplied
3/8-inch (6pt) Box Wrench	1	Not Supplied
Diagonal Cutters	1	Not Supplied

### Installing

- Place the wheelchair in a well ventilated area where work can be performed without risking damage to carpeting or floor covering.
- Verify the joystick On/Off switch is in the OFF position and disconnect joystick. Refer to Disconnecting/Connecting the MK5 Joysticks on page 93.
- Perform one of the following:
  - Wheelchairs without Formula PTO Plus - Remove the seat. Refer to Removing/Installing the Seat Assembly on page 56.
  - Wheelchairs with Formula PTO Plus - Tilt the seat back. Refer to Tilting the Seat Assembly on page 63.
- Remove the top shroud. Refer to Removing/Installing the Shrouds on page 77.
- If necessary, disconnect right and left motor leads to allow access to the front of the battery tray.
- Move aside the motor leads and controller cable to allow unobstructed access to the front of the battery tray.

NOTE: Perform this section on one battery at a time starting with the rear battery. Repeat STEP 6 to position the remaining battery into the battery tray.

- Perform one of the following to position the battery into the battery tray:
  - Batteries With Built In Lifting Strap - Use built in lifting strap to position battery into the battery tray (Detail "A" of FIGURE 11.1).
  - Batteries Without Built In Lifting Strap - Use the battery lifting strap to position battery into the battery tray. When battery is in proper position, remove lifting strap (Detail "B" of FIGURE 11.1).
- Using the battery retaining strap, secure the two batteries into the battery tray.
- If necessary, connect the wiring harness to the two batteries. Refer to Connecting/Disconnecting the Battery Wiring Harness on page 85.
- Reconnect RIGHT and LEFT motor leads to allow access to the FRONT of the battery tray, if disconnected in STEP 5.

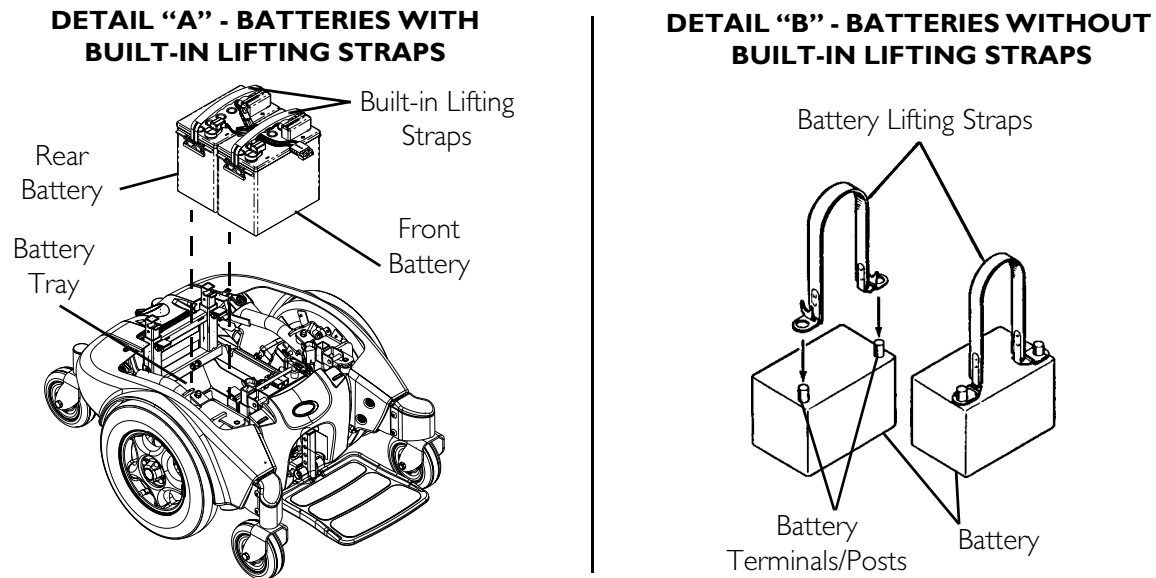
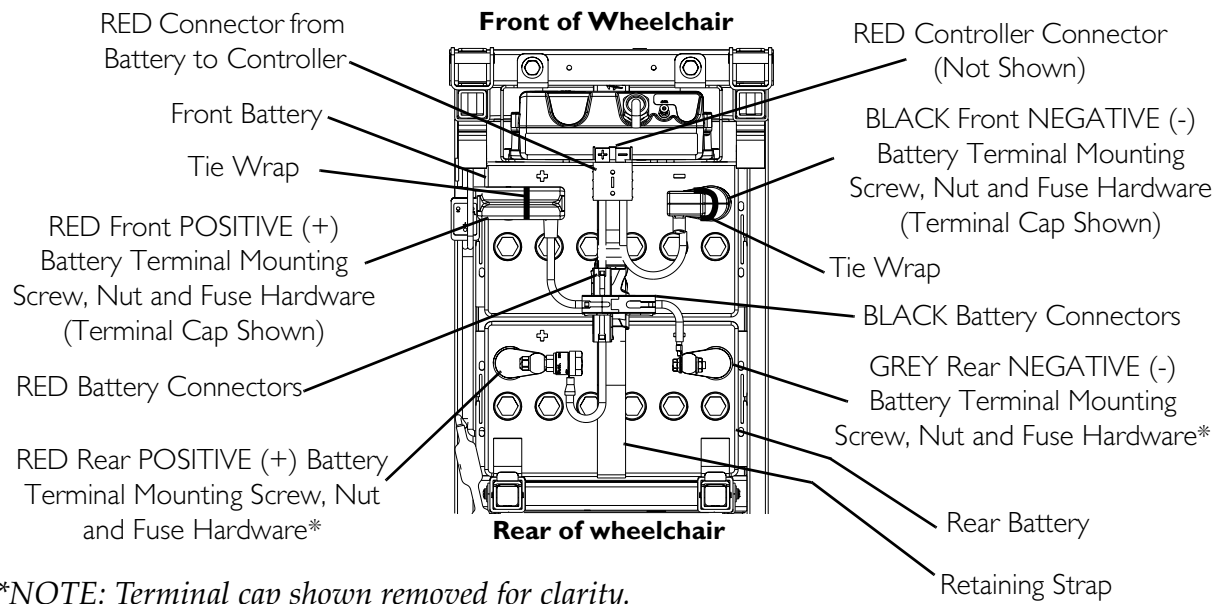

**FIGURE 11.1** Batteries with/without Lifting straps

11. Connect the front battery to the controller (RED connector). Refer to FIGURE 11.2.
12. Connect the rear battery to the front battery (RED and BLACK connectors). Refer to FIGURE 11.2.
13. Reinstall the top shroud. Refer to Removing/Installing the Shrouds on page 77.
14. Perform one of the following:
  - A. Wheelchairs without Formula PTO Plus - Reinstall the seat. Refer to Removing/Installing the Seat Assembly on page 56.
  - B. Wheelchairs with Formula PTO Plus - Tilt the seat forward. Refer to Tilting the Seat Assembly on page 63.
15. Connect the joystick. Refer to Disconnecting/Connecting the MK5 Joysticks on page 93.

*NOTE: New battery(ies) MUST be fully charged BEFORE using, otherwise the life of the battery(ies) will be reduced.*

16. If necessary, charge the battery(ies). Refer to Charging Batteries on page 87.



**FIGURE 11.2** Installing/Removing the Batteries

## Removing

1. Place the wheelchair in a well ventilated area where work can be performed without risking damage to carpeting or floor covering.
2. Verify the joystick ON/OFF switch is in the OFF position and disconnect joystick. Refer to [Disconnecting/Connecting the MK5 Joysticks](#) on page 93.
3. Perform one of the following:
  - A. Wheelchairs without Formula PTO Plus - Remove the seat. Refer to [Removing/Installing the Seat Assembly](#) on page 56.
  - B. Wheelchairs with Formula PTO Plus - Tilt the seat back. Refer to [Tilting the Seat Assembly](#) on page 63.
4. Remove the top shroud. Refer to [Removing/Installing the Shrouds](#) on page 77.
5. If necessary, disconnect right and left motor leads to allow access to the front of the battery tray.
6. Disconnect the front battery from controller (RED connector). Refer to FIGURE 11.2.
7. Move aside the motor leads and controller cable to allow unobstructed access to the front of the battery tray.
8. Disconnect the rear battery from the front battery (RED and BLACK connectors). Refer to FIGURE 11.2.
9. If necessary, disconnect the wiring harness from batteries. Refer to [Connecting/Disconnecting the Battery Wiring Harness](#) on page 85.
10. Unfasten the retaining strap that secures the two batteries in the battery tray.

*NOTE: Perform this section on one battery at a time starting with the FRONT battery. Repeat STEP 10 to remove remaining battery from battery tray.*

11. Perform one of the following to remove the battery from the battery tray:
  - A. Batteries With Built-in Lifting Strap- Use built in lifting strap to remove the battery from the battery tray (Detail “A” of FIGURE 11.1).
  - B. Batteries Without Built-in Lifting Strap- Use the battery lifting strap to remove the battery from the battery tray (Detail “B” of FIGURE 11.1).

## Connecting/Disconnecting the Battery Wiring Harness

*NOTE: Perform this section on one battery at a time starting with the front battery.*

*NOTE: The front battery has three connectors - two to the rear battery wiring harness (RED and BLACK) and one to the controller cable (RED), and the rear battery has two connectors (RED and BLACK) to the front battery wiring harness.*

*NOTE: Both the front and rear wiring harnesses are shipped with the POSITIVE (+) RED battery cable and mounting screw connected. Use the exposed, threaded portion of the mounting screw to secure the POSITIVE (+) RED cable to the POSITIVE (+) terminal.*

---

### ⚠ WARNING

**DO NOT** remove fuse or mounting hardware from **POSITIVE (+) RED** battery cable/mounting screw.

**All battery terminal covers (two [2] on the front battery and two [2] on the rear battery) MUST** be installed prior to use.

---

### Connecting

*NOTE: For this procedure, refer to FIGURE 11.3.*

1. Peel back RED battery terminal cover to expose RED battery cable connection to battery terminal.
2. Peel back BLACK battery terminal cover from BLACK battery cable on front battery or GREY battery terminal cover from BLACK battery cable on rear battery.
3. Using the mounting screws and nuts, secure the NEGATIVE (-) BLACK battery cable to NEGATIVE (-) battery terminal/post as shown in FIGURE 11.3.
4. Using the mounting screws and nuts, secure the POSITIVE (+) RED battery cable to POSITIVE (+) battery terminal/post as shown in FIGURE 11.3.
5. Verify wiring harness is correctly installed and securely tightened.
6. Verify proper battery orientation.
7. Reposition battery terminal covers over battery post(s).
8. Using new tie-wraps, secure the terminal covers to the battery terminals as shown in FIGURE 11.3.

9. Repeat STEPS 1-8 to install and connect the rear battery to the rear battery harness.

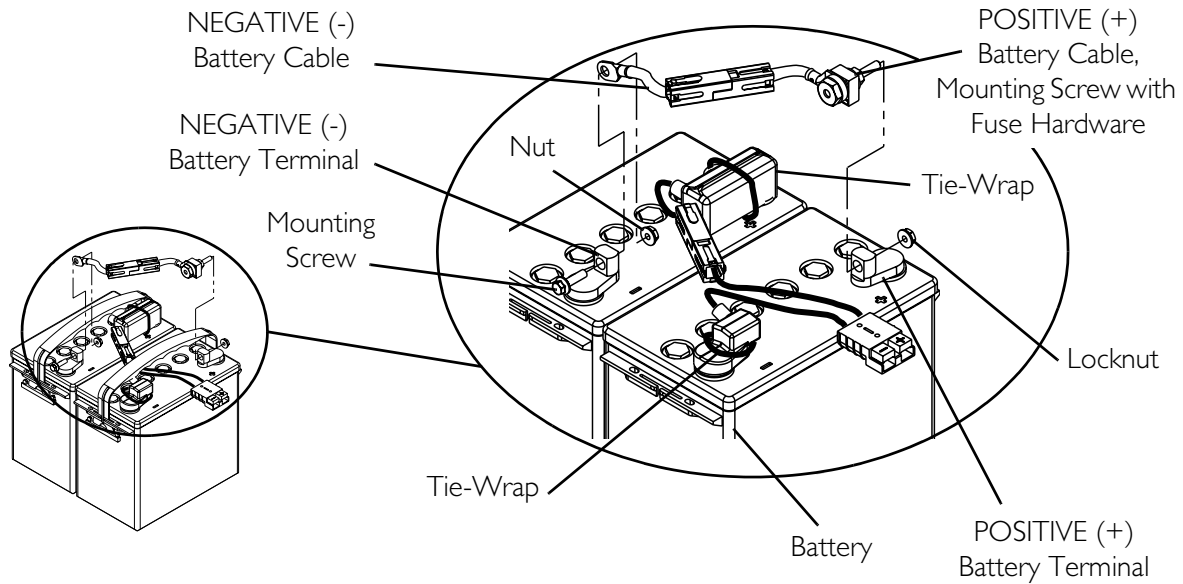

**FIGURE 11.3** Connecting/Disconnecting the Battery Wiring Harness

## Disconnecting

*NOTE: For this procedure, refer to FIGURE 11.3.*

1. Remove the existing tie-wraps that secure the battery terminal covers to the battery terminals.
2. Peel back RED battery terminal cover to expose RED battery cable connection to battery terminal.
3. Peel back BLACK battery terminal cover from BLACK battery cable on front battery or GREY battery terminal cover from BLACK battery cable on rear battery.
4. Remove the mounting screws and nuts that secure the POSITIVE (+) RED battery cable to the POSITIVE (+) battery terminal/post as shown in FIGURE 11.3.
5. Remove the mounting screws and nuts that secure the NEGATIVE (-) BLACK battery cable to the NEGATIVE (-) battery terminal/post as shown in FIGURE 11.3.
6. Set wiring harness aside.
7. Repeat STEPS 1-6 to disconnect the rear battery from the rear battery harness.

---

## Charging Batteries

---

### **⚠ DANGER**

When using an extension cord, use only a three wire extension cord having at least 16 AWG (American Wire Gauge) wire and the same or higher electrical rating as the device being connected. Use of improper extension cord could result in a risk of fire and electric shock. Three prong to two prong adapters should not be used. Use of three prong adapters can result in improper grounding and present a shock hazard to the user.

---

### **⚠ WARNING**

Never attempt to recharge the batteries by attaching cables directly to the battery terminals.

**DO NOT** attempt to recharge the batteries and operate the wheelchair at the same time.

**DO NOT** attempt to recharge the batteries when the wheelchair has been exposed to **ANY** type of moisture.

**DO NOT** attempt to recharge the batteries when the wheelchair is outside.

**DO NOT** sit in the wheelchair while charging the batteries.

**DO NOT** attempt to recharge the batteries using **BOTH** the on-board battery charger **AND** an independent battery charger (plugged into the joystick charger port) at the **SAME** time. Doing so will reduce the life of the batteries.

**READ** and **CAREFULLY** follow the manufacturer's instructions for each charger (supplied or purchased). If charging instructions are not supplied, consult a qualified technician for proper procedures prior to use.

---

### **CAUTION**

New batteries **MUST** be fully charged prior to initial use of the wheelchair.

**Always** fully charge new batteries before initial use or battery life will be reduced.

**As a general rule, you should recharge your batteries as frequently as possible to assure the longest possible life and to minimize required charging time. Plan to recharge them when you do not anticipate using the wheelchair.**

---

Some basic concepts which will help you understand this automatic process are:

The amount of electrical current drawn within a given time to charge a battery is called "charge rate". If, due to usage, the charge stored in the battery is low, the charge rate is high. As a charge builds up, the charge rate is reduced, and the battery charger rate decreases to a "trickle charge".

*NOTE: If the batteries need to be charged more often or take longer to charge than normal, they may need to be replaced. Contact a qualified technician.*

*NOTE: The batteries can be charged using the on-board battery charger or by plugging an independent battery charger into the port located on the front of the SPJ-80/DPJ/MPJ joysticks.*

## Battery Charger Operation

---

### **⚠ WARNING**

**READ and CAREFULLY follow the manufacturer's instructions for each charger (supplied or purchased). If charging instructions are not supplied, consult a qualified technician for proper procedures prior to use.**

**If the circuit breaker trips repeatedly, IMMEDIATELY unplug charger and contact dealer or a qualified technician.**

**Three prong to two prong adapters should not be used. Using three prong adapters can result in improper grounding and present a shock hazard to user.**

---

### On-Board Battery Charger

---

### **⚠ WARNING**

**Use of improper extension cord could result in risk of fire and electric shock.**

**When using an extension cord, use only a three wire extension cord having at least 16 AWG (American Wire Gauge) wire and the same or higher electrical rating as the device being connected.**

**Ensure the pins of the extension cord plug are the same number, size, and shape as those on the charger.**

**DO NOT under any circumstances cut or remove the round grounding plug from the charger AC cable plug or the extension cord plug.**

---

*NOTE: For this procedure, refer to FIGURE 11.4.*

*NOTE: Charge indicator light is only visible with rear shroud removed.*

1. Plug the female connector of the AC power cord (supplied) to the AC receptacle on the charger and plug in the male connector on the AC power cord into the wall outlet.
2. The On/Off LED indicator illuminates solid RED indicating that the charger is On.
3. If the On/Off LED indicator is "Blinking" RED, this is abnormal. Unplug AC power cord from the on-board battery charger and wall outlet. Contact Invacare at the number listed on the back page of this manual.
4. When the On/Off LED indicator light is Off, charger is Off.
5. When the Charge LED indicator light is YELLOW, the batteries are charging.
6. When the Charge LED indicator light is solid GREEN, the batteries are fully charged (as their condition will allow). At this point, the charger automatically stops charging.
7. When charging is complete, unplug the male connector of the AC power cord from the wall outlet and then unplug the female connector of the AC power cord from the AC receptacle on the charger.



**⚠ WARNING**

**DO NOT** operate wheelchair with AC power cord attached to the wheelchair.

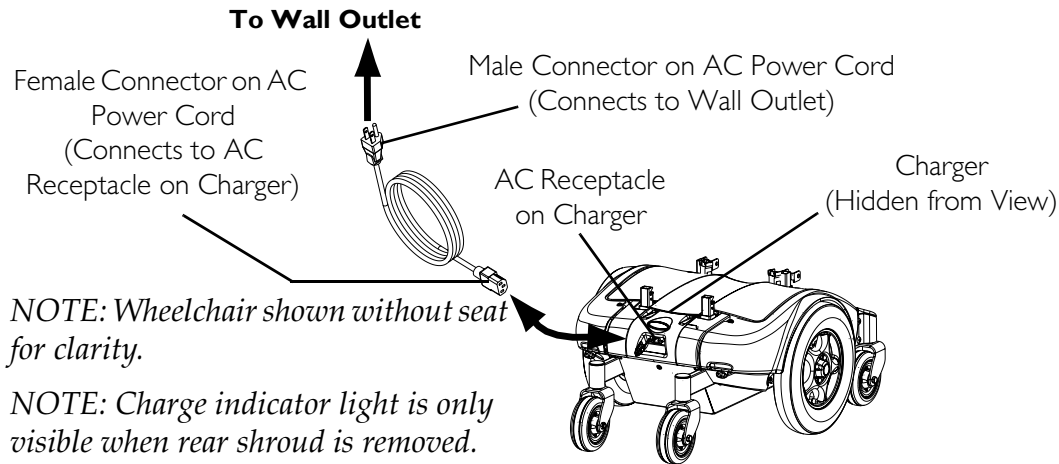

CHARGING INDICATOR	STATUS
YELLOW	Charging (Under 80%)
“Blinking” YELLOW	Partially Charges (Over 80%)
Solid GREEN	Fully Charges
LED “Off”	Charger Disconnected
Solid RED or “Blinking” RED	Under Voltage
	Over Voltage
	Over Temperature

**FIGURE 11.4** On-Board Battery Charger

### Independent Charger

*NOTE: For this procedure, refer to FIGURE 11.5.*

*NOTE: The charger port located on the Front of the joystick requires the use of an independent charger. The independent charger is NOT supplied with the wheelchair.*

**⚠ WARNING**

**READ** and **CAREFULLY** follow the individual instructions for each charger (supplied or purchased). If charging instructions are not supplied, consult a qualified technician for proper procedures.

**CAUTION**

**DO NOT** use an independent charger with an output rating of over 8A (amps). Otherwise, damage may occur.

**Required Items:** Battery Charger\*, Power Cord\*\*

\*NOTE: Item not supplied.

\*\*NOTE: AC power cord (3-prong plug, 15 ampere current rating; industrial type).

Wheelchair with MK5 SPJ-80/DPJ/MPJ/SPJ+ joystick:

1. Attach the battery charger connector to the charger port on the front of the joystick.
2. Plug the charger's AC power cord or extension into the grounded 110-volt wall outlet.
3. Unplug the AC power cord or extension once charging is complete.

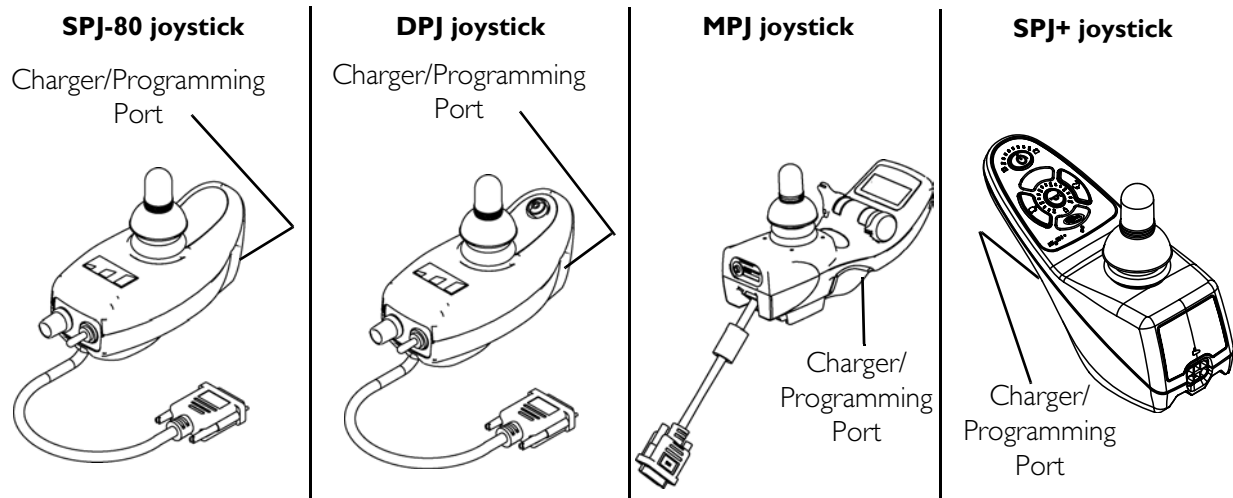

**FIGURE 11.5** Independent Charger

---

# SECTION 12—ELECTRONICS

---

## **⚠ WARNING**

**After ANY adjustments, repair or service and BEFORE use, make sure that all attaching hardware is tightened securely - otherwise injury or damage may result.**

**Before performing any maintenance, adjustment or service verify that On/Off switch on the joystick is in the OFF position.**

---

## Repositioning the Joystick

### Adjustable Seat Back Angle (ASBA) Model

*NOTE: For this procedure, refer to FIGURE 12.1.*

1. Turn the lever on the adjustment lock to release the adjustment lock from joystick mounting tube.
2. Remove the joystick from the wheelchair.
3. Remove the three hex screws that secure joystick mounting bracket, the threaded hole half clamp and the opened hole half clamp to the arm tube.
4. Reposition the threaded hole half clamp and opened hole half clamp on the opposite arm tube. Make sure threaded hole half clamp is on the inside of arm tube.
5. While holding the two half clamps, install the front hex screw into the two half clamps. Securely tighten.
6. Line up mounting holes of the joystick mounting bracket with the mounting holes in the two half clamps.
7. Secure the joystick mounting bracket to the two half clamps with the remaining two hex screws.
8. Slide tube through the bracket to the desired position.
9. Slide adjustment lock over end of tube and secure adjustment lock to tube by turning lever on adjustment lock.

*NOTE: If adjustment lock does not fit over tube, rotate 180°.*

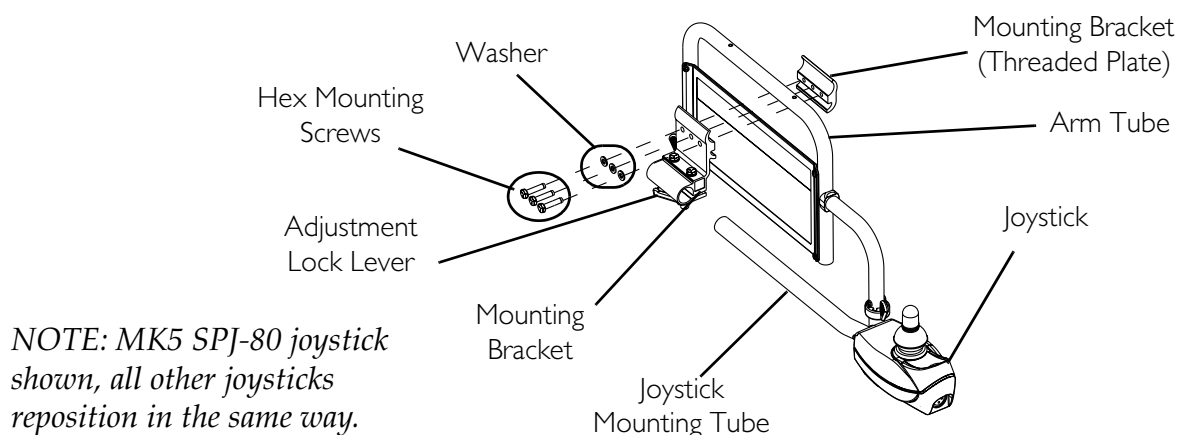

**FIGURE 12.1** Repositioning the Joystick - Adjustable Seat Back Angle (ASBA) Model

### Van Seat Model

*NOTE: For this procedure, refer to FIGURE 12.2.*

*NOTE: Take note of position and orientation of mounting hardware for reinstalling the joystick assembly.*

1. Turn the adjustment lock lever to release the joystick mounting tube from the mounting bracket.
2. Remove the joystick from the wheelchair.
3. Remove the three hex mounting screws, spacers and locknuts that secure the mounting bracket to the three mounting holes on the arm frame.

*NOTE: The mounting bracket is mounted to the inside of the arm frame.*

4. Reposition the mounting bracket on the opposite arm frame.
5. Using the three hex mounting screws, spacers and locknuts secure the mounting bracket to the three mounting holes of the arm frame.
6. If necessary, perform the following to reposition the adjustment lock:
  - A. Slide the adjustment lock from the mounting bracket.
  - B. Rotate adjustment lock 180° and slide adjustment lock over the opposite end of the mounting bracket.
7. Slide joystick mounting tube through the mounting bracket to the desired position and secure adjustment lock to tube by turning lever on adjustment lock.

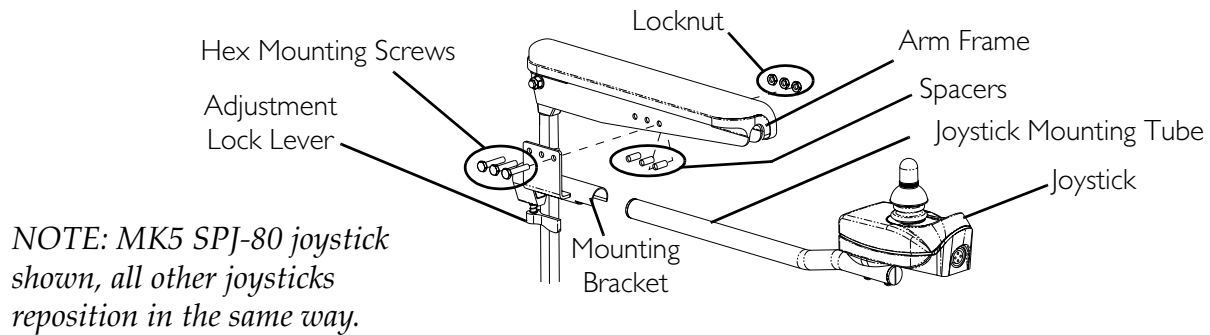

**FIGURE 12.2** Repositioning the Joystick - Van Seat Model

## Disconnecting/Connecting the MK5 Joysticks

*NOTE: For this procedure, refer to FIGURE 12.3.*

### Disconnecting

1. Loosen the thumb screws on the joystick connector.
2. Disconnect the joystick connector from the controller connector.

### Connecting

1. Align the joystick connector with the controller connector.
2. Secure the joystick connector to the controller connector using the thumb screws on the controller connector.

### **⚠ WARNING**

**The excess joystick cable must be coiled, and tie-wrapped to the rear of the seat frame to ensure that cable does NOT become entangled or damaged during normal operation of seating system - otherwise injury or damage may result.**

3. If necessary, coil and tie wrap excess joystick cable to rear of seat frame.

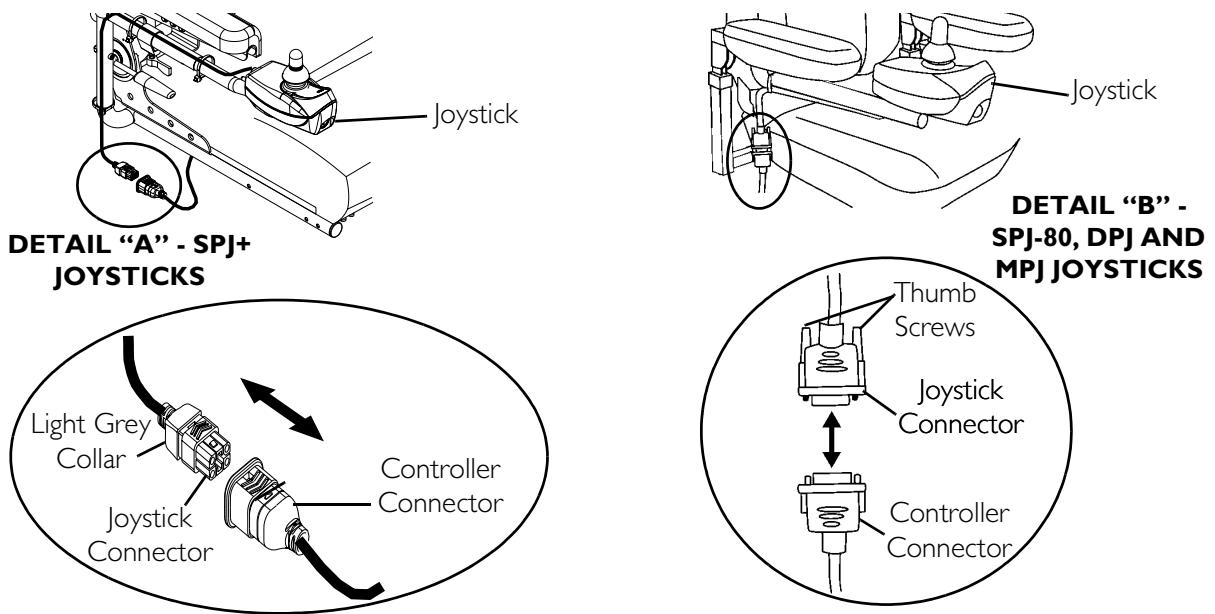

NOTE: Only Van seat shown. Joysticks on ASBA seats connect/disconnect the same way.

FIGURE 12.3 Disconnecting/Connecting the MK5 Joysticks

## Programming the Control Module

### ⚠ WARNING

**DO NOT** attempt to program the control module. This section **MUST** be performed by a qualified technician.

NOTE: For this procedure, refer to FIGURE 12.4.

NOTE: Connect programmer to multi-function charger port located on front of joystick as shown in FIGURE 12.4.

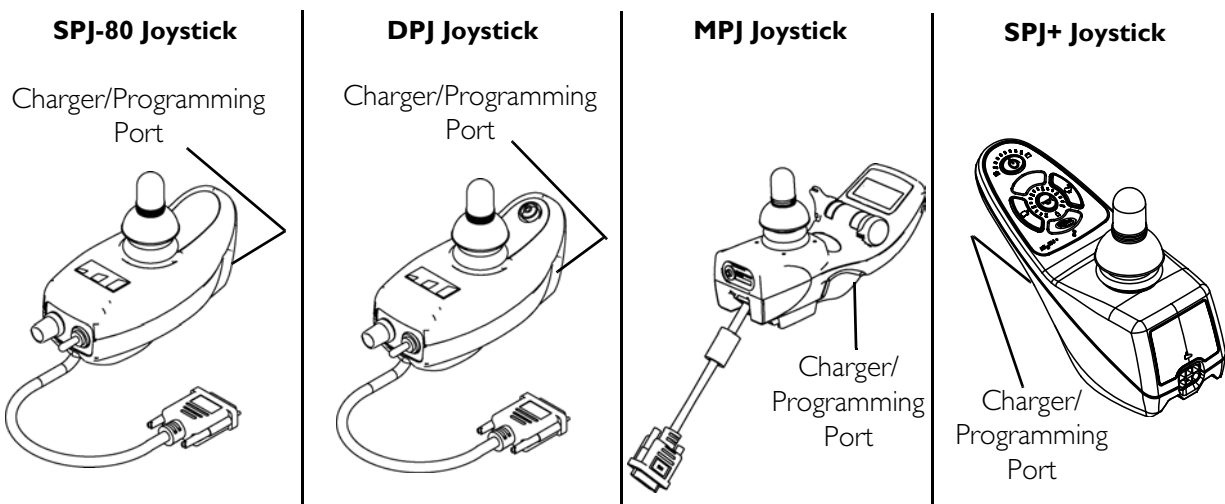

FIGURE 12.4 Programming the Control Module

# SECTION I3—TRANSPORT READY PACKAGE

*NOTE: The information in this section is for wheelchairs ordered with the transport ready package ONLY.*

---

## **⚠ WARNING**

Contact Invacare Corporation (800-333-6900) with any questions about using this wheelchair for seating in a motor vehicle.

When feasible, wheelchair occupants should transfer into the vehicle seat and use the OEM (Original Equipment Manufacturer) vehicle-installed restraint system.

This wheelchair has been dynamically tested in a forward-facing mode with the specified crash test dummy restrained by **BOTH** pelvic and shoulder belt(s), and that **BOTH** pelvic and upper torso belt(s) should be used to reduce the possibility of head and chest impacts with vehicle components.

Use **ONLY** Wheelchair Tie-down and Occupant Restraint Systems (WTORS) which meet the requirements of the SAE (Society of Automotive Engineers) J2249 Recommended Practice during travel in a motor vehicle.

This wheelchair has been tested for seating in a motor vehicle with the factory installed seating system **ONLY**.

This wheelchair **MUST** be in a forward facing position during travel in a motor vehicle.

This wheelchair is equipped and has been dynamically tested to rely on **WHEELCHAIR-ANCHORED** pelvic belts. If desired, **VEHICLE-ANCHORED** pelvic belts may be used.

**IT IS STRONGLY RECOMMENDED THAT BOTH PELVIC AND UPPER-TORSO BELT(S) BE USED TO REDUCE THE RISK OF INJURY.**

To reduce the potential of injury to vehicle occupants, wheelchair-mounted accessories, including but not limited to IV poles, trays, respiratory equipment, backpacks, and other personal items should be removed and secured separately.

Postural supports, positioning devices, and/or strap(s) should not be relied on for occupant restraint. These items may be used **IN ADDITION TO** the wheelchair-anchored or vehicle-anchored belts.

Wheelchairs with adjustable seat angles **MUST** be set to 10°.

**DO NOT** alter or substitute wheelchair frame parts, components, or seating systems.

A sudden stop and/or collision may structurally damage your wheelchair. Wheelchairs involved in such incidents should be replaced.

Spill proof batteries, such as “gel cells”, should be installed on wheelchairs to be used during travel in a motor vehicle.

**TRANSPORT READY PACKAGES ARE NOT RETROFITTABLE TO EXISTING MODELS AND ARE NOT FIELD SERVICEABLE.**

## About Transport Ready Packages

TRRO includes four factory-installed transport brackets and a wheelchair anchored pelvic belt. TRRO has been crash-tested in accordance with ANSI/RESNA WC Vol 1 Section 19 Frontal Impact Test requirements for wheelchairs with a 168 lb crash dummy, which corresponds to a person with a weight of 114 to 209 lbs.

TRBKTS includes four factory-installed wheelchair transport brackets. TRBKTS has not been crash-tested in accordance with WC 19. Invacare recommends that these transport brackets be used only to secure an unoccupied wheelchair during transport.

As of this date, the Department of Transportation has not approved any tie-down systems for transportation of a user while in a wheelchair, in a moving vehicle of any type. It is Invacare's position that users of wheelchairs should be transferred into appropriate seating in vehicles for transportation and use be made of the restraints made available by the auto industry. Invacare cannot and does not recommend any wheelchair transportation systems.

## Compliance Information

This wheelchair conforms with the requirements of the ANSI/RESNA WC/Vol. 1 - Section 19.

*NOTE: ANSI = American National Standards Institute, RESNA= Rehabilitation Engineering and Assistive Technology Society of North America.*

This wheelchair has been dynamically tested in a forward-facing mode with the specified crash test dummy, which corresponds to a person **with a weight of 114-209 pounds**, restrained by BOTH pelvic and shoulder belts in accordance with ANSI/RESNA WC Vol 1 Section 19. BOTH pelvic and upper torso belts should be used to reduce the possibility of head and chest impacts with vehicle components.

## Specifications

MODEL	WHEELCHAIR WEIGHT LIMIT
M9I Standard	Up to 300 lbs
M9I Heavy Duty	Up to 400 lbs



# Securing the Wheelchair to the Vehicle

## Positioning the Wheelchair in the Vehicle

### ⚠ WARNING

This wheelchair must be in a forward facing position during travel in a motor vehicle.

The recommended clear zones for wheelchair seated occupants restrained by **BOTH** pelvic and upper torso belt(s) and **ONLY** by a pelvic belt are shown in the diagrams and described below.

Frontal Clear Zones (FCZ) need to be **LARGER** when upper torso belt(s) are **NOT** used.

The rear clear zone of 16-inches is measured from the rearmost point on an occupant's head.

The frontal clear zone is measured from the frontmost point on an occupant's head and is 26-inches with pelvic and upper-torso belt(s) and 37-inches with **ONLY** a pelvic belt.

The frontal clear zone may not be achievable for wheelchair-seated drivers.

The estimated seated height (HHT) from the ground or floor to the top of the wheelchair-seated occupant's head ranges from approximately 47-inches for a small adult female to about 61-inches for a tall adult male.

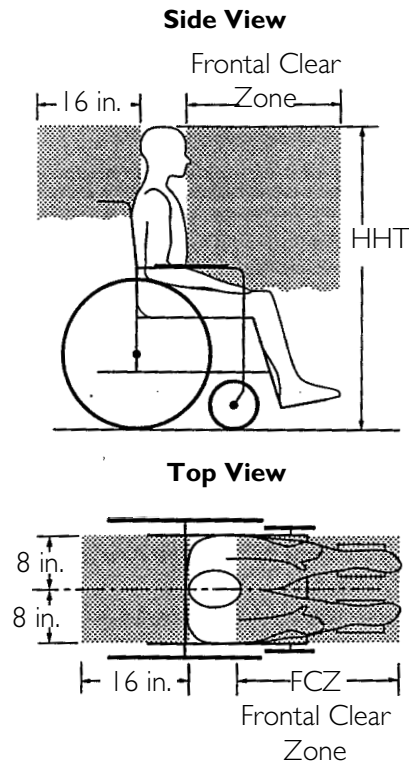

## Securement Points

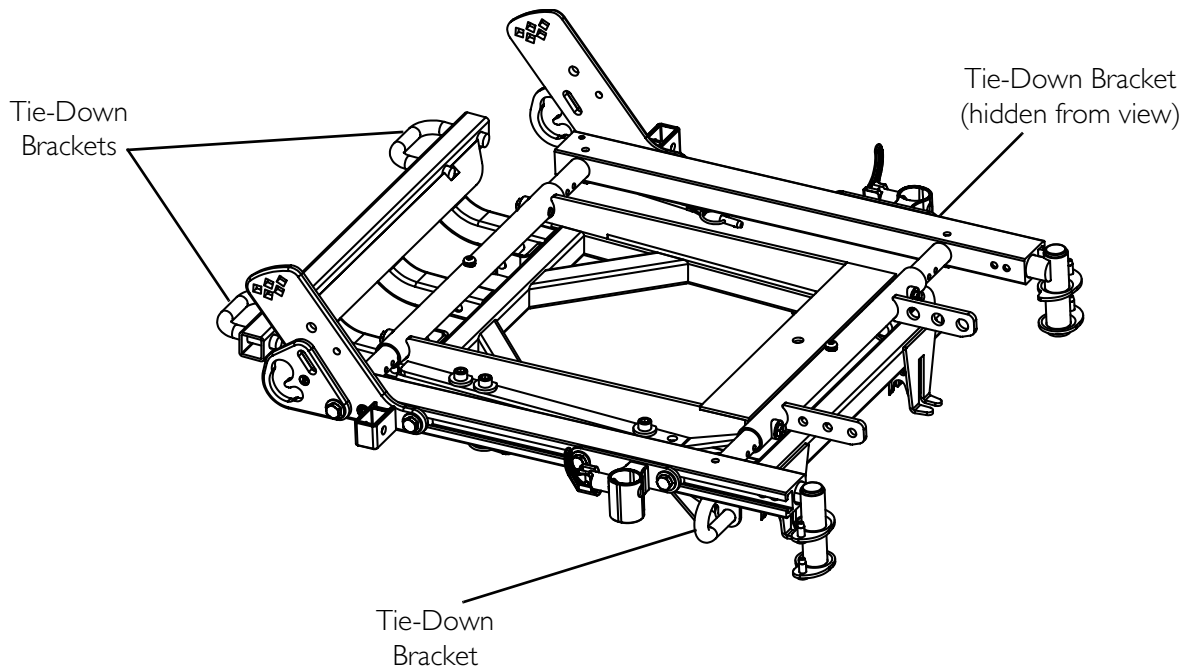

**FIGURE 13.1** Securement Points

## Securing the Wheelchair

This wheelchair is to be used only with Wheelchair Tie-down and Occupant Restraint Systems (WTORS) that have been installed in accordance with the manufacturer's instructions and SAE J2249.

*NOTE: A copy of SAE J2249 Wheelchair Tie-down and Occupant Restraint Systems (WTORS) for use in Motor Vehicles can be obtained from: SAE International, 400 Commonwealth Drive, Warrendale, PA 15096-0001, (877) 606-7232 or (724) 776-4970.*

Attach WTORS to the tie-down brackets in accordance with the manufacturer's instructions and SAE J2249.

# Securing the Occupant

## Wheelchair-Anchored Belts

### ⚠ WARNING

The pelvic belt that is provided by Invacare has been tested for use in a motor vehicle on this wheelchair **ONLY**. **DO NOT** replace the pelvic belt with a different style pelvic belt.

*NOTE: For this procedure, refer to FIGURE 13.2.*

The wheelchair has been provided with a pelvic belt which meets the requirements of ANSI/RESNA W/C 19.

The pelvic belt, provided by Invacare, has been designed to accommodate use on either side of the vehicle. If necessary, follow the instructions below to reverse the orientation of the pelvic belt to accommodate the vehicle-anchored upper torso belt.

1. Install the pelvic belt pin (DETAIL "A" of FIGURE 2) into the large end of the slot in the belt mounting bracket. Rotate downward and forward until it snaps into place into the small end of the slot.

*NOTE: Note the position of the male end of the belt when installing the pelvic belt onto the belt mounting brackets. The male end of the pelvic belt (DETAIL "A" of FIGURE 2) has a pin which is used to secure the vehicle-anchored upper torso belt.*

2. Repeat STEP 1 for the opposite belt mounting bracket.
3. Install the vehicle-anchored upper torso belt onto the pin on the male end of the pelvic belt.

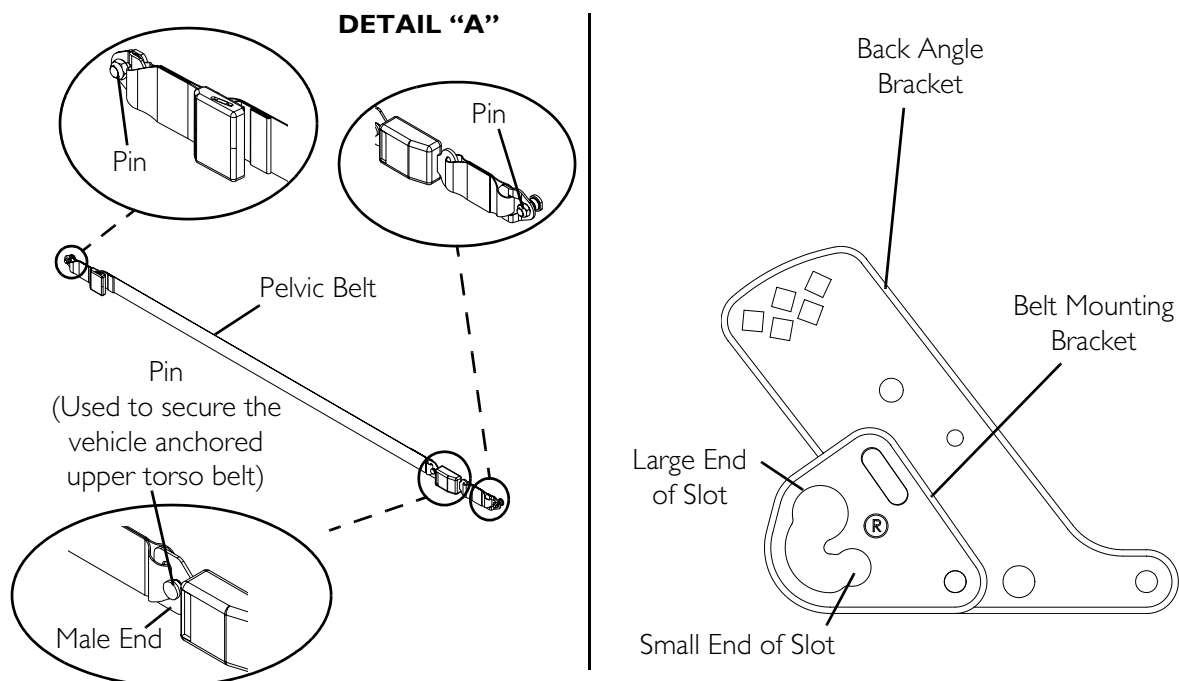

**FIGURE 13.2** Wheelchair-Anchored Belts

## Vehicle-Anchored Belts

*NOTE: For this procedure, refer to FIGURE 13.3.*

This wheelchair has an overall rating of “A” with regard to accommodating the use and fit of vehicle-anchored belts. This rating is scored as follows:

RATING	DESCRIPTION
<b>A</b>	Excellent
<b>B</b>	Good
<b>C</b>	Fair
<b>D</b>	Poor

The test for Lateral Stability Displacement for Point (P) is shown in FIGURE 13.3. The average test result for point (P) is 0.44-inches (11.2 mm).

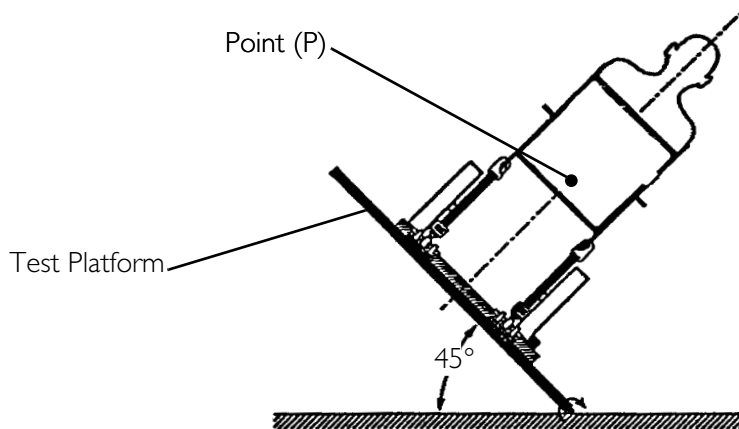

*NOTE: Rear view of the wheelchair and human surrogate secured on test platform and tilted to 45°.*

**FIGURE 13.3** - Vehicle-Anchored Belts

## Seating System

### **⚠ WARNING**

**This wheelchair has been tested for seating in a motor vehicle with the factory installed seating system ONLY.**

Ensure that the factory installed seating system is secured to the wheelchair frame before operation. Refer to the seating system owner’s manual.

## Positioning Belts

### ⚠ WARNING

The angle of the pelvic belt should be within the preferred zone of 45 to 75 degrees to the horizontal **OR** within the optional zone of 30 to 45 degrees to the horizontal.

Steeper side-view pelvic belt angles are especially important if the pelvic belt is intended to be used for postural support in addition to occupant restraint in a frontal crash. Steeper angles will reduce the tendency for a vertical gap to develop between the user and the belt due to compliance of seat cushions and belt movement, thereby reducing the tendency for the user to slip under the belt and for the belt to ride up on the soft abdomen during normal use.

Steeper belt angles also reduce the tendency for upper-torso belts to pull the pelvic belt onto the abdomen during frontal impact loading.

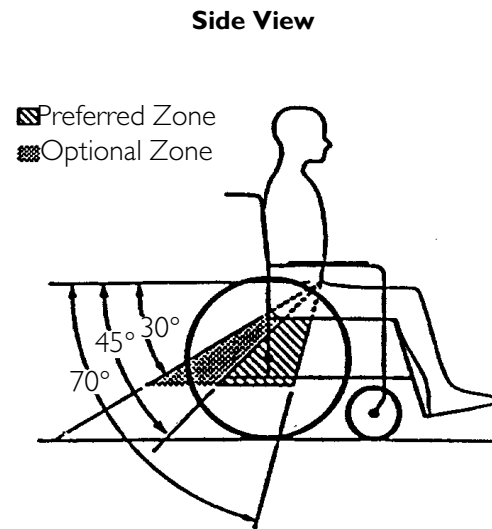

*NOTE: For this procedure, refer to FIGURE 13.4.*

1. The pelvic belt should be worn low across the front of the pelvis.
2. Position the upper torso belt(s) over the shoulders.
3. The belt(s) should not be held away from the body by wheelchair components or parts, including but not limited to wheelchair armrests or wheels. Refer to FIGURE 13.4 for proper and improper positioning of the belts.
4. Ensure the belt(s) are not twisted.
5. Adjust belts as firmly as possible, being mindful of user comfort.

**DO POSITION BELT INSIDE OF  
ARMRESTS, WHEELS, ETC.**

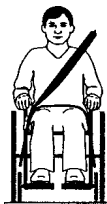

**DO NOT POSITION BELT OUTSIDE OF  
ARMRESTS, WHEELS, ETC.**



**FIGURE 13.4** Positioning Belts

# NOTES

# NOTES

---

# LIMITED WARRANTY

**PLEASE NOTE: THE WARRANTY BELOW HAS BEEN DRAFTED TO COMPLY WITH FEDERAL LAW APPLICABLE TO PRODUCTS MANUFACTURED AFTER JULY 4, 1975.**

This warranty is extended only to the original purchaser/user of our products.

This warranty gives you specific legal rights and you may also have other legal rights which vary from state to state.

With regards to the original purchaser/user only, Invacare warrants the front and rear frames to be free from defects in materials and workmanship for a period of five years from date of purchase; seat frame for a period of five years from the date of purchase; motors and gearboxes for a period of one and a half years from the date of purchase; electronics for a period of one year and all remaining components for one year from the date of purchase except upholstered materials, padded materials and tires/wheels. If within such warranty period any product shall be proven to be defective, such product shall be repaired or replaced, at Invacare's option. This warranty does not include any labor or shipping charges incurred in replacement part installation or repair of any such product. Invacare's sole obligation and your exclusive remedy under this warranty shall be limited to such repair and/or replacement.

For warranty service, please contact the dealer from whom you purchased your Invacare product. In the event you do not receive satisfactory warranty service, please write directly to Invacare at the address on the bottom of the back cover. Provide dealer's name address, date of purchase, indicate nature of the defect and, if the product is serialized, indicate the serial number. Do not return products to our factory without our prior consent.

**LIMITATIONS AND EXCLUSIONS: THE FOREGOING WARRANTY SHALL NOT APPLY TO SERIAL NUMBERED PRODUCTS IF THE SERIAL NUMBER HAS BEEN REMOVED OR DEFACED, PRODUCTS SUBJECT TO NEGLIGENCE, ACCIDENT, IMPROPER OPERATION, MAINTENANCE OR STORAGE, COMMERCIAL OR INSTITUTIONAL USE, PRODUCTS MODIFIED WITHOUT INVACARE'S EXPRESS WRITTEN CONSENT INCLUDING, BUT NOT LIMITED TO, MODIFICATION THROUGH THE USE OF UNAUTHORIZED PARTS OR ATTACHMENTS; PRODUCTS DAMAGED BY REASON OF REPAIRS MADE TO ANY COMPONENT WITHOUT THE SPECIFIC CONSENT OF INVACARE, OR TO A PRODUCT DAMAGED BY CIRCUMSTANCES BEYOND INVACARE'S CONTROL, AND SUCH EVALUATION WILL BE SOLELY DETERMINED BY INVACARE. THE WARRANTY SHALL NOT APPLY TO PROBLEMS ARISING FROM NORMAL WEAR OR FAILURE TO ADHERE TO THESE INSTRUCTIONS. A CHANGE IN OPERATING NOISE, PARTICULARLY RELATIVE TO MOTORS AND GEARBOXES DOES NOT CONSTITUTE A FAILURE. ALL SUCH DEVICES WILL EXHIBIT A CHANGE IN OPERATING NOISE DUE TO AGING.**

**THE FOREGOING EXPRESS WARRANTY IS EXCLUSIVE AND IN LIEU OF ANY OTHER WARRANTIES WHATSOEVER, WHETHER EXPRESS OR IMPLIED, INCLUDING THE IMPLIED WARRANTIES OF MERCHANTABILITY AND FITNESS FOR A PARTICULAR PURPOSE, AND THE SOLE REMEDY FOR VIOLATIONS OF ANY WARRANTY WHATSOEVER, SHALL BE LIMITED TO REPAIR OR REPLACEMENT OF THE DEFECTIVE PRODUCT PURSUANT TO THE TERMS CONTAINED HEREIN, THE APPLICATION OF ANY IMPLIED WARRANTY WHATSOEVER SHALL NOT EXTEND BEYOND THE DURATION OF THE EXPRESS WARRANTY PROVIDED HEREIN. INVACARE SHALL NOT BE LIABLE FOR ANY CONSEQUENTIAL OR INCIDENTAL DAMAGES WHATSOEVER.**

**THIS WARRANTY SHALL BE EXTENDED TO COMPLY WITH STATE/PROVINCIAL LAWS AND REQUIREMENTS.**

Invacare Corporation [www.invacare.com](http://www.invacare.com)



*Yes, you can.®*

**USA**  
One Invacare Way  
Elyria, Ohio USA  
44036-2125  
800-333-6900

**Canada**  
570 Matheson Blvd E Unit 8  
Mississauga Ontario  
L4Z 4G4 Canada  
800-668-5324

Invacare, Yes, you can., the Medallion Design and Pronto are registered trademarks of Invacare Corporation. M91, SureStep, Formula, MK5, EX, NX, SPJ, DPJ and MPJ are trademarks of Invacare Corporation  
© 2006 Invacare Corporation

Part No. 1141450

Rev A - 01/11/06