

# ***HURRICANE***

***The Ultimate in Style & Performance®***



**OWNER'S MANUAL**

**Pride**  
Mobility Products Corp.  
[www.pridemobility.com](http://www.pridemobility.com)

Exeter, PA St. Catherines, ON 1-800-800-8586

# SAFETY GUIDELINES



**An authorised Pride Provider or qualified technician must perform the initial set up of this scooter and must perform all of the procedures in this manual.**

The symbols below are used throughout this owner's manual and on the scooter to identify warnings and important information. It is very important for you to read them and understand them completely.



**WARNING!** Indicates a potentially hazardous condition/situation. Failure to follow designated procedures can cause either personal injury, component damage, or malfunction. On the product, this icon is represented as a black symbol on a yellow triangle with a black border.



**MANDATORY!** These actions should be performed as specified. Failure to perform mandatory actions can cause personal injury and/or equipment damage. On the product, this icon is represented as a white symbol on a blue dot with a white border.



**PROHIBITED!** These actions are prohibited. These actions should not be performed at any time or in any circumstances. Performing a prohibited action can cause personal injury and/or equipment damage. On the product, this icon is represented as a black symbol with a red circle and red slash.

Please fill out the following information for quick reference:

Pride Provider: _____	
Address: _____	
Phone Number: _____	
Purchase Date: _____	Serial Number: _____

*NOTE: This owner's manual is compiled from the latest specifications and product information available at the time of publication. We reserve the right to make changes as they become necessary. Any changes to our products may cause slight variations between the illustrations and explanations in this manual and the product you have purchased. The latest/current version of this manual is available on our website.*

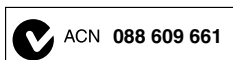

Copyright © 2007  
Pride Mobility Products Corp.

INFMANU2635/Rev D/April 2007

# CONTENTS

<b>I. INTRODUCTION</b> .....	4
<b>II. SAFETY</b> .....	5
<b>III. EMI/RFI</b> .....	17
<b>IV. SPECIFICATIONS</b> .....	18
<b>V. YOUR PMV</b> .....	20
<b>VI. BATTERIES AND CHARGING</b> .....	24
<b>VII. OPERATION</b> .....	29
<b>VIII. COMFORT ADJUSTMENTS</b> .....	31
<b>IX. DISASSEMBLY AND ASSEMBLY</b> .....	34
<b>X. BASIC TROUBLESHOOTING</b> .....	36
<b>XI. CARE AND MAINTENANCE</b> .....	38
<b>XII. WARRANTY</b> .....	41

# I. INTRODUCTION

## SAFETY

WELCOME to Pride Mobility Products Corporation (Pride). The product you have purchased combines state of the art components with **safety**, comfort and styling in mind. We are confident the design features will provide you with the conveniences you expect during your daily activities. Understanding how to **safely** operate and care for this product should bring you years of trouble free operations and service.

**Read and follow** all instructions, warnings, and notes in this manual and all other accompanying literature before attempting to operate this product for the first time. In addition, your **safety** depends upon you, as well as your provider, caretaker, or healthcare professional in using good judgement.

If there is any information in this manual which you do not understand, or if you require additional assistance for setup or operation, please contact your authorized Pride Provider. **Failure to follow the instructions, warnings, and notes in this manual and those located on your Pride product can result in personal injury or product damage and will void Pride's product warranty.**

## PURCHASER'S AGREEMENT

By accepting delivery of this product, you promise that you will not change, alter or modify this product or remove or render inoperable or unsafe any guards, shields, or other safety features of this product; fail, refuse or neglect to install any retrofit kits from time to time provided by Pride to enhance or preserve the safe use of this product.

## INFORMATION EXCHANGE

We want to hear your questions, comments, and suggestions about this manual. We would also like to hear about the safety and reliability of your new PMV, and about the service you received from your authorized Pride Provider. Please notify us of any change of address, so we can keep you apprised of important information about safety, new products, and new options that can increase your ability to use and enjoy your PMV. Please feel free to contact us at the address below:

Pride Mobility Products Corporation  
Attn: Customer Care Department  
182 Susquehanna Ave.  
Exeter, PA 18643-2694

***NOTE: If you ever lose or misplace your product registration card or your copy of this manual, contact us and we will be glad to send you a new one immediately.***

## PRIDE OWNERS CLUB

As an owner of a Pride product, you are encouraged to enroll in the Pride Owners Club. Complete and return your enclosed product registration card or visit Pride's web site at [www.pridemobility.com](http://www.pridemobility.com).

From our home page, select "Owners Club" to enter a page dedicated to current and potential Pride product owners. You will gain access to interviews, stories, recreation ideas, daily living tips, product and funding information, and interactive message boards. These message boards invite you to communicate with other Pride customers as well as Pride representatives who are available to assist you with any questions or concerns.

# II. SAFETY

## PRODUCT SAFETY SYMBOLS

The symbols below are used on the PMV to identify warnings, mandatory actions, and prohibited actions. It is very important for you to read and understand them completely.



**Read and follow the information in the owner's manual.**



**Do not allowed unsupervised children to play near the PMV while the batteries are charging.**



**Maximum seating weight.**



**Pinch/Crush points created during assembly.**



**Corrosive chemicals contained in battery. Use only AGM or Gel-Cell batteries to reduce the risk of leakage or explosive conditions.**



**EMI-RFI- This product has been tested and passed at an immunity level of 20 V/m.**



**Unlocked and in freewheel mode.**

**Place unit on level ground and stand behind or to one side when changing from drive mode to freewheel mode or freewheel mode to drive mode.**

**Locked and in drive mode.**

## II. SAFETY



**Use only AGM or Gel-Cell batteries.**

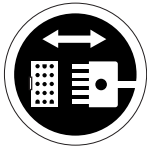

**Front-to-rear plug orientation.**



**Do not raise or lower the power seat while the PMV is in motion.**



**Do not remove anti-tip wheels.**



**Do not use a cell phone, walkie/talkie, laptop, or other radio transmitter while operating.**



**Avoid exposure to rain, snow, ice, salt, or standing water whenever possible. Maintain and store in a clean and dry condition.**



**Removal of grounding prong can create electrical hazard. If necessary, properly install an approved 3-pronged adapter to an electrical outlet having 2-pronged plug access.**

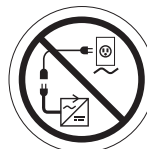

**Do not connect an extension cord to the AC/DC converter or the battery charger.**



**Contact with tools can cause electrical shock.**

## II. SAFETY



**Do not open the battery pack until reading the instructions within the owner's manual on how to do so.**

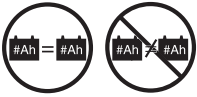

**Do not use batteries with different amp-hour (Ah) capacities. Do not mix old and new batteries. Always replace both batteries at the same time.**



**Do not lift the mobility product while seated in it.**



**Explosive conditions exist!**



**Keep your hands away from the tires when driving. Be aware that loose fitting clothing can become caught in the drive tires.**



**Disposal and recycling-Contact your authorised Pride Provider for information on proper disposal of your Pride product and its packaging.**



**Contains lead.**



**Wear safety goggles.**

# II. SAFETY

## GENERAL



**MANDATORY! Do not operate your new PMV for the first time without completely reading and understanding this owner's manual.**

Your PMV is a state-of-the-art life-enhancement device designed to increase mobility. Pride provides an extensive variety of products to best fit the individual needs of the PMV user. Please be aware that the final selection and purchasing decision regarding the type of PMV to be used is the responsibility of the PMV user who is capable of making such a decision and his/her healthcare professional (i.e., medical doctor, physical therapist, etc.).

The contents of this manual are based on the expectation that a mobility device expert has properly fitted the PMV to the user and has assisted the prescribing healthcare professional and/or the authorized Pride Provider in the instruction process for the use of the product.

There are certain situations, including some medical conditions, where the PMV user will need to practice operating the PMV in the presence of a trained attendant. A trained attendant can be defined as a family member or care professional specially trained in assisting a PMV user in various daily living activities.

As you begin using your PMV during daily activities, you will probably encounter situations in which you will need some practice. Simply take your time and you will soon be in full and confident control as you maneuver through doorways, on and off lifts, up and down ramps, and over moderate terrain.

Below are some precautions, tips, and other safety considerations that will you become accustomed to operating the PMV safely.

## MODIFICATIONS

Pride has designed and engineered your PMV to provide maximum mobility and utility. However, under no circumstances should you modify, add, remove, or disable any feature, part, or function of your PMV.



**WARNING! Do not modify your PMV in any way not authorized by Pride.**

## REMOVABLE PARTS



**WARNING! Do not attempt to lift or move your PMV by any of its removable parts, including the armrests, seat, or shroud.**

## PRE-RIDE SAFETY CHECK

Get to know the feel of your PMV and its capabilities. Pride recommends that you perform a safety check before each use to make sure your PMV operates smoothly and safely.



## II. SAFETY

Perform the following inspections prior to using your PMV:

- Check for proper tire inflation (if equipped with pneumatic tyres).
- Check all electrical connections. Make sure they are tight and not corroded.
- Check all harness connections. Make sure they are secured properly.
- Check the brakes.
- Check battery charge.

If you discover a problem, contact your authorized Pride Provider for assistance.

### TIRE INFLATION

If your PMV is equipped with pneumatic tyres, you should check or have the air pressure checked at least once a week. Proper inflation pressures will prolong the life of your tyres and help ensure the smooth operation of your PMV.

**WARNING! It is critically important that 30-35 psi tire pressure be maintained in pneumatic tyres at all times. Do not underinflate or overinflate your tyres. Low pressure may result in loss of control, and overinflated tyres may burst. Failure to maintain 30-35 psi tire pressure in pneumatic tyres at all times may result in tire and/or wheel failure.**



**WARNING! Inflate your PMV tyres from a regulated air source with an available pressure gauge. Inflating your tyres from an unregulated air source could overinflate them, resulting in a burst tire.**

**WARNING! When changing a tire, remove only the center lug nut, then remove the tire. If any further disassembly is required, deflate the tyre completely or it may explode.**

### WEIGHT LIMITATIONS

Your PMV is rated for a maximum weight capacity. Refer to the specifications table for information.



**WARNING! Stay within the specified weight capacity of your PMV. Exceeding the weight capacity voids your warranty. Pride will not be held responsible for injuries and/or property damage resulting from failure to observe weight limitations.**



**WARNING! Do not carry passengers on your PMV. Carrying passengers on your PMV may affect the center of gravity, resulting in a tip or a fall.**

### INCLINE INFORMATION

More and more buildings have ramps with specified degrees of inclination, designed for easy and safe access. Some ramps may have turning switchbacks (180-degree turns) that require you to have good cornering skills on your PMV.

- Proceed with extreme caution as you approach the downgrade of a ramp or other incline.
- Take wide swings with your PMV around any tight corners. If you do that, the PMV's rear wheels will follow a wide arc, not cut the corner short, and not bump into or get hung up on any railing corners.
- When driving down a ramp, keep the PMV's speed adjustment set to the slowest speed setting to ensure a safely controlled descent.
- Avoid sudden stops and starts.

## II. SAFETY

When climbing an incline, try to keep your PMV moving. If you must stop, start up again slowly, and then accelerate cautiously. When driving down an incline, do so by setting the speed adjustment dial to the slowest setting and driving in the forward direction only. If your PMV starts to move down the incline faster than you anticipated or desired, allow it to come to a complete stop by releasing the throttle control lever. Then engage the throttle control lever slightly to ensure a safely controlled descent.

**WARNING! When climbing an incline, do not zigzag or drive at an angle up the face of the incline. Drive your PMV straight up the incline. This greatly reduces the possibility of a tip or a fall. Always exercise extreme caution when negotiating an incline.**

**WARNING! Do not drive your PMV across the side of an incline or diagonally up or down an incline; do not stop, if possible, while driving up or down an incline.**



**WARNING! You should not travel up or down a potentially hazardous incline (i.e., areas covered with snow, ice, cut grass, or wet leaves).**

**WARNING! When on any sort of an incline or decline, never place the PMV in freewheel mode while seated on it or standing next to it.**

**WARNING! Even though your PMV is capable of climbing slopes greater than those illustrated in figure 1, do not, under any circumstances, exceed the incline guidelines or any other specifications presented in this manual. Doing so could cause instability in your PMV, resulting in personal injury and/or damage to your PMV.**

Handicap public access ramps are not subject to government regulation in all countries, and therefore do not necessarily share the same standard degree of slope. Other inclines may be natural or, if man-made, not designed specifically for PMVs. Figure 1 illustrates your PMV's stability and its ability to climb grades under various weight loads and under controlled testing conditions.

These tests were conducted with the PMV's seat in the highest position and adjusted rearward on the seat base to its farthest rearward position. Use this information as a guideline. Your PMV's ability to travel up inclines is affected by your weight, your PMV's speed, your angle of approach to the incline, and your PMV setup.

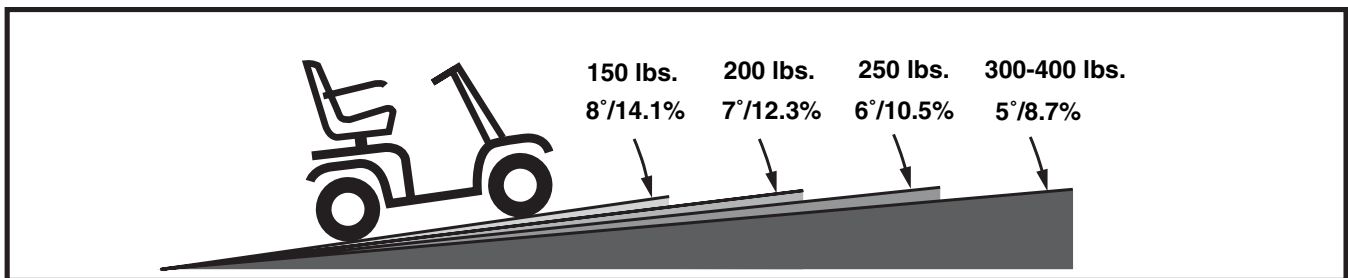

Figure 1. Maximum Recommended Incline Angles

**WARNING! Any attempt to climb or descend a slope steeper than what is shown in figure 1 may put your PMV in an unstable position and cause it to tip, resulting in personal injury.**



**WARNING! Never carry an oxygen tank weighing more than 15 lbs. Never fill the rear basket with contents exceeding 15 lbs.**

## II. SAFETY

When you approach an incline, it is best to lean forward. See figures 2 and 2A. This shifts the center of gravity of you and your PMV toward the front of the PMV for improved stability.

**NOTE:** When negotiating ramps, if the throttle control lever is released while moving forward, the powered PMV may "rollback" approximately 1 foot before the brake engages. If the throttle control lever is released while moving in reverse, the powered PMV may "rollback" approximately 3 feet before the brake engages.

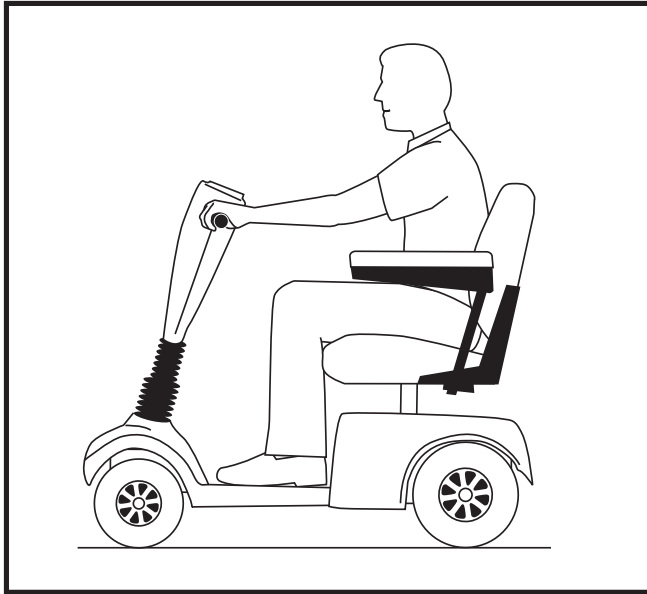

Figure 2. Normal Driving Position

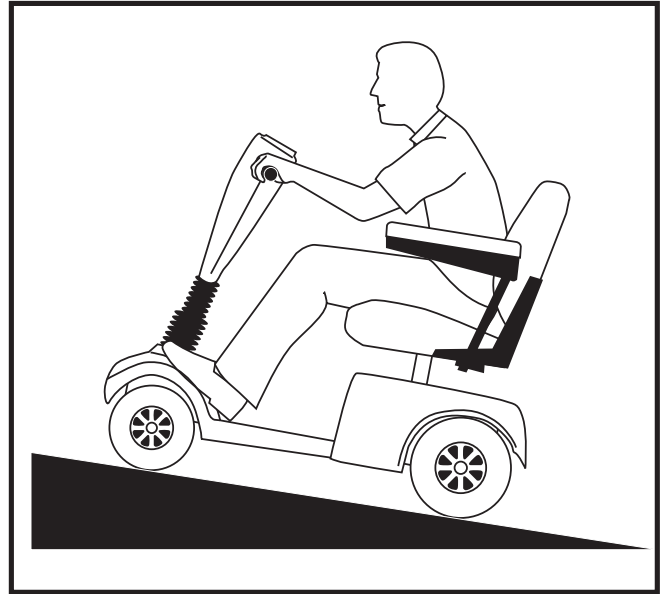

Figure 2A. Increased Stability Driving Position

### CORNERING INFORMATION

Excessively high cornering speeds can create the possibility of tipping. Factors which affect the possibility of tipping include, but are not limited to, cornering speed, steering angle (how sharply you are turning), uneven road surfaces, inclined road surfaces, riding from an area of low traction to an area of high traction (such as passing from a grassy area to a paved area – especially at high speed while turning), and abrupt directional changes. High cornering speeds are not recommended. If you feel that you may tip over in a corner, reduce your speed and steering angle (i.e., lessen the sharpness of the turn) to prevent your PMV from tipping.



**WARNING! When cornering sharply, reduce your speed. When using your PMV at higher speeds, do not corner sharply. This greatly reduces the possibility of a tip or fall. To avoid personal injury or property damage, always exercise common sense when cornering.**

### BRAKING INFORMATION

Your PMV is equipped with these powerful brake systems:

- Regenerative: Uses electricity to rapidly slow the vehicle when the throttle control lever returns to the center/stop position.
- Disc Park Brake: Activates mechanically after regenerative braking slows the vehicle to near stop, or when power is removed from the system for any reason.
- Handbrake: Gives you additional stopping power when squeezed.

## II. SAFETY

### OUTDOOR DRIVING SURFACES

Your PMV is designed to provide optimum stability under normal driving conditions—dry, level surfaces composed of concrete, blacktop, or asphalt. However, Pride recognizes that there will be times when you will encounter other surface types. For this reason, your PMV is designed to perform admirably on packed soil, grass, and gravel. Feel free to use your PMV safely on lawns and in park areas.

- Reduce your PMV's speed when driving on uneven terrain and/or soft surfaces.
- Avoid tall grass that can become tangled in the running gear.
- Avoid loosely packed gravel and sand.
- If you feel unsure about a driving surface, avoid that surface.

### PUBLIC STREETS AND ROADWAYS



**WARNING!** You should not operate your PMV on public streets and roadways. Be aware that it may be difficult for traffic to see you when you are seated on your PMV. Obey all local pedestrian traffic rules. Wait until your path is clear of traffic, and then proceed with extreme caution.

### STATIONARY OBSTACLES (STEPS, CURBS, ETC.)

**WARNING!** Do not drive near raised surfaces, unprotected ledges, and/or drop-offs (curbs, porches, stairs, etc.).

**WARNING!** Do not attempt to have your PMV climb or descend an obstacle that is inordinately high.



**WARNING!** Do not attempt to have your PMV proceed backward down any step, curb, or other obstacle. This may cause the PMV to tip.

**WARNING!** Be sure your PMV is traveling perpendicular to any curb you may be required to ascend or descend. See figures 3 and 3A.

**WARNING!** Do not attempt to negotiate a curb that has a height greater than 2 in.

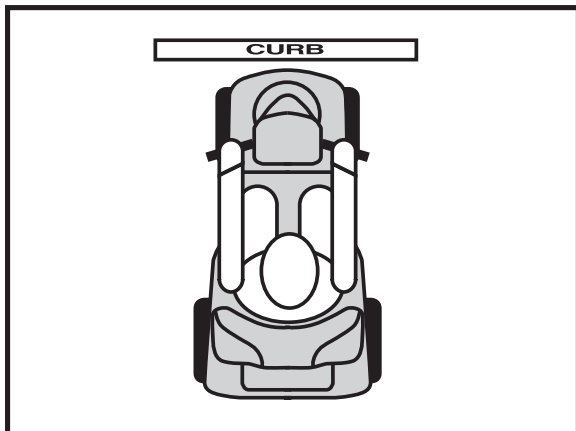

Figure 3. Correct Curb Approach

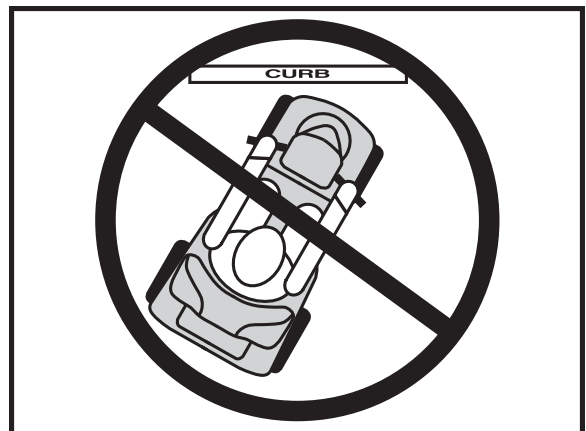

Figure 3A. Incorrect Curb Approach

## II. SAFETY

### INCLEMENT WEATHER PRECAUTIONS

Exposure of your PMV to inclement weather conditions should be avoided whenever possible. If suddenly caught up in rain, snow, severe cold or heat while operating your PMV, proceed to shelter at the earliest opportunity. Thoroughly dry your PMV before storing, charging, or operating your PMV.



**WARNING! Operating in rain, snow, salt, mist/spray conditions and on icy/slippery surfaces may have an adverse affect on the electrical system. Maintain and store your PMV in a dry and clean condition.**



**WARNING! Prolonged exposure to hot or cold conditions may affect the temperature of upholstered and non-upholstered items on the PMV, possibly resulting in skin irritation. Exercise caution when using your PMV in extremely hot or cold conditions or when exposing your PMV to direct sunlight for prolonged periods of time.**

### FREEWHEEL MODE

Your PMV is equipped with a manual freewheel lever that, pushed forward, allows the PMV to be pushed. For more information about how to place your PMV into and out of freewheel mode, see V. “Your PMV.”



**WARNING! When your PMV is in freewheel mode, the braking system is disengaged.**

- **Disengage the drive motors only on a level surface.**
- **Ensure the key is removed from the key switch.**
- **Stand beside the PMV to engage or disengage freewheel mode. Never sit on a PMV to do this.**
- **After you have finished pushing your PMV, always return it to the drive mode to lock the brakes.**

An added feature built into the PMV is “**push-too-fast**” protection which safeguards the PMV against gaining excessive speed while in freewheel mode.

“Push-too-fast” operates differently depending on which of two conditions exists:

- If the key is switched “off” while in freewheel mode, the PMV’s controller activates regenerative braking when the PMV is pushed faster than a maximum threshold which has been preprogrammed. In this case, the controller is acting as a speed governor.
- If the key is switched “on” while in freewheel mode, you will encounter considerable resistance at any speed. This prevents the PMV from gaining unwanted momentum should the manual freewheel lever inadvertently be released while driving the PMV.

### STAIRS AND ESCALATORS

PMVs are not designed to travel up or down stairs or escalators. Always use an elevator.



**WARNING! Do not use your PMV to negotiate steps or escalators.**

### DOORS

- Determine if the door opens toward or away from you.
- Use your hand to turn the knob or push the handle or push-bar.
- Drive your PMV gently and slowly forward to push the door open. Or drive your PMV gently and slowly backwards to pull the door open.

## II. SAFETY

### ELEVATORS

Modern elevators have a door edge safety mechanism that, when pushed, reopens the door(s).

- If you are in the doorway of a elevator when the door(s) begin to close, push on the rubber door edge or allow the rubber door edge to contact the PMV and the door will reopen.
- Use care that pocketbooks, packages, or PMV accessories do not become caught in elevator doors.

*NOTE: If your PMV's turning radius is greater than 60 in., it may be difficult to maneuver in elevators and building entrances. Use caution when attempting to turn or maneuver your PMV in small spaces, and avoid areas that might pose a problem.*

### LIFT/ELEVATION PRODUCTS

If you will be traveling with your PMV, you may find it necessary to use a lift/elevation product to aid in transportation. Pride recommends that you closely review the instructions, specifications, and safety information set forth by the manufacturer of the lift/elevation product before using that product.



**WARNING! Never sit on your PMV when it is being used in connection with any type of lift/elevation product. Your PMV was not designed with such use in mind and any damage or injury incurred from such use is not the responsibility of Pride.**

### BATTERIES

In addition to following the warnings below, be sure to comply with all other battery handling information.



**WARNING! Battery posts, terminals, and related accessories contain lead and lead compounds. Wash hands after handling.**

**WARNING! PMV batteries are heavy (refer to specifications table). Lifting weight beyond your capacity could result in personal injury. If necessary, get someone physically able to lift the PMV batteries for you.**



**WARNING! Always protect the batteries from freezing and never charge a frozen battery.**

**WARNING! Connect the battery harnesses in the proper manner. RED (+) cables must be connected to positive (+) battery terminals/posts. BLACK (-) cables must be connected to negative (-) battery terminals/posts. Failure to connect your battery harnesses in the proper manner may result in personal injury and/or damage to your PMV. REPLACE cables immediately if damaged. Protective caps must be installed over all battery terminals.**

*NOTE: If you encounter a damaged or cracked battery, immediately enclose it in a plastic bag and call your authorized Pride Provider for instructions on disposal. Your authorized Pride Provider will also have the necessary information on battery recycling, which is our recommended course of action.*

### MOTOR VEHICLE TRANSPORT

Pride recommends that you do not remain seated in your PMV while traveling in a motor vehicle. The PMV should be stowed in the trunk of a car or in the back of a truck or van with the batteries removed and properly secured.



**WARNING! Although your PMV may be equipped with a positioning belt, this belt is not designed to provide restraint during motor vehicle transport. Anyone travelling in a motor vehicle should be properly secured in the motor vehicle seat with safety belts fastened securely.**

**WARNING! Do not sit on your PMV while it is in a moving vehicle.**

## II. SAFETY



**WARNING! Always be sure your PMV and its batteries are properly secured when it is being transported. Batteries should be secured in an upright position, and protective caps should be installed on the battery terminals. Batteries should not be transported with any flammable or combustible items.**

Although your PMV may be equipped with a positioning belt, this belt is not designed to provide proper restraint during motor vehicle transport. Anyone traveling in a motor vehicle should be properly secured in the motor vehicle seat with safety belts fastened securely.



**WARNING! Do not sit on your PMV while it is in a moving vehicle.**

**WARNING! Ensure your PMV and its batteries are properly secured when being transported.**

### PREVENTING UNINTENDED MOVEMENT



**WARNING! If you anticipate being seated in a stationary position for an extended period of time, turn off the power. This will prevent unexpected motion from inadvertent throttle control lever contact.**

### GETTING ONTO AND OFF OF YOUR PMV

Getting onto and off of your PMV requires a good sense of balance. Please observe the following safety tips when getting onto and off of your PMV:

- Remove the key from the key switch.
- Ensure that your PMV is not in freewheel mode. See V. “Your PMV.”
- Ensure that the seat is secured into place.
- Pivot the armrests up to make getting onto and off of the PMV easier.

**WARNING! Position yourself as far back as possible in the PMV seat to prevent the PMV from tipping and causing injury.**



**WARNING! Avoid putting all of your weight on the PMV armrests and do not use the armrests for weight bearing purposes, such as transfers. Such use may cause the PMV to tip, resulting in a fall from the PMV.**

**WARNING! Avoid putting all of your weight on the floorboard. Such use may cause the PMV to tip.**

### REACHING AND BENDING

Avoid reaching or bending while driving your PMV. Bending forward creates the risk of accidental throttle control lever contact. Bending to the side while seated creates the risk of tipping. It is important to maintain a stable centre of gravity and keep the PMV from tipping. Pride recommends that the PMV user determine his/her personal limitations and practice bending and reaching in the presence of a qualified attendant.



**WARNING! Do not bend, lean, or reach for objects if you have to pick them up from the PMV deck or from either side of the PMV. Movements such as these may change your center of gravity and the weight distribution of the PMV and cause your PMV to tip.**



**WARNING! Keep your hands away from the tires when driving. Be aware that loose fitting clothing can become caught in drive tires.**

## II. SAFETY

### POSITIONING BELTS

Your authorized Pride Provider, therapist(s), and other healthcare professionals are responsible for determining your requirement for a positioning belt in order to operate your PMV safely.



**WARNING! If you require a positioning belt to safely operate your PMV, make sure it is fastened securely. Serious personal injury may result if you fall from the PMV.**

### PRESCRIPTION DRUGS/PHYSICAL LIMITATIONS

The PMV user must exercise care and common sense when operating his/her PMV. This includes awareness of safety issues when taking prescribed or over-the-counter drugs or when the user has specific physical limitations.



**WARNING! Consult your physician if you are taking prescribed or over-the-counter medication or if you have certain physical limitations. Some medications and limitations may impair your ability to operate your PMV in a safe manner.**

### ALCOHOL/SMOKING

The PMV user must exercise care and common sense when operating his/her PMV. This includes awareness of safety issues while under the influence of alcohol, or while smoking.

**WARNING! Do not operate your PMV while you are under the influence of alcohol, as this may impair your ability to drive safely.**



**WARNING! Pride strongly recommends that you do not smoke cigarettes while seated on your PMV, although the PMV seat has passed the necessary testing requirements for cigarette smoking. You must adhere to the following safety guidelines if you decide to smoke cigarettes while seated on your PMV.**

- Do not leave lit cigarettes unattended.
- Keep ashtrays a safe distance from the seat cushions.
- Always make sure cigarettes are completely extinguished before disposal.



# III. EMI/RFI

## ELECTROMAGNETIC AND RADIO FREQUENCY INTERFERENCE (EMI/RFI)



**WARNING! Laboratory tests have shown that electromagnetic and radio frequency waves can have an adverse affect on the performance of electrically-powered mobility vehicles.**

Electromagnetic and Radio Frequency Interference can come from sources such as cellular phones, mobile two-way radios (such as walkie-talkies), radio stations, TV stations, amateur radio (HAM) transmitters, wireless computer links, microwave signals, paging transmitters and medium-range mobile transceivers used by emergency vehicles. In some cases, these waves can cause unintended movement or damage to the control system. Every electrically-powered mobility vehicle has an immunity (or resistance) to EMI. The higher the immunity level, the greater the protection against EMI. This product has been tested and has passed at an immunity level of 20 V/M.



**WARNING! Be aware that cell phones, two-way radios, laptops, and other types of radio transmitters may cause unintended movement of your electrically-powered mobility vehicle due to EMI. Exercise caution when using any of these items while operating your mobility vehicle and avoid coming into close proximity of radio and TV stations.**



**WARNING! The addition of accessories or components to the electrically-powered mobility vehicle can increase the susceptibility of the vehicle to EMI. Do not modify your PMV in any way not authorized by Pride.**

**WARNING! The electrically-powered mobility vehicle itself can disturb the performance of other electrical devices located nearby, such as alarm systems.**

*NOTE: For further information on EMI/RFI, go to the Resource Center on [www.pridemobility.com](http://www.pridemobility.com). If unintended motion or brake release occurs, turn the PMV off as soon as it is safe to do so. Call Pride at 800-424-8205 to report the incident.*

# IV. SPECIFICATIONS

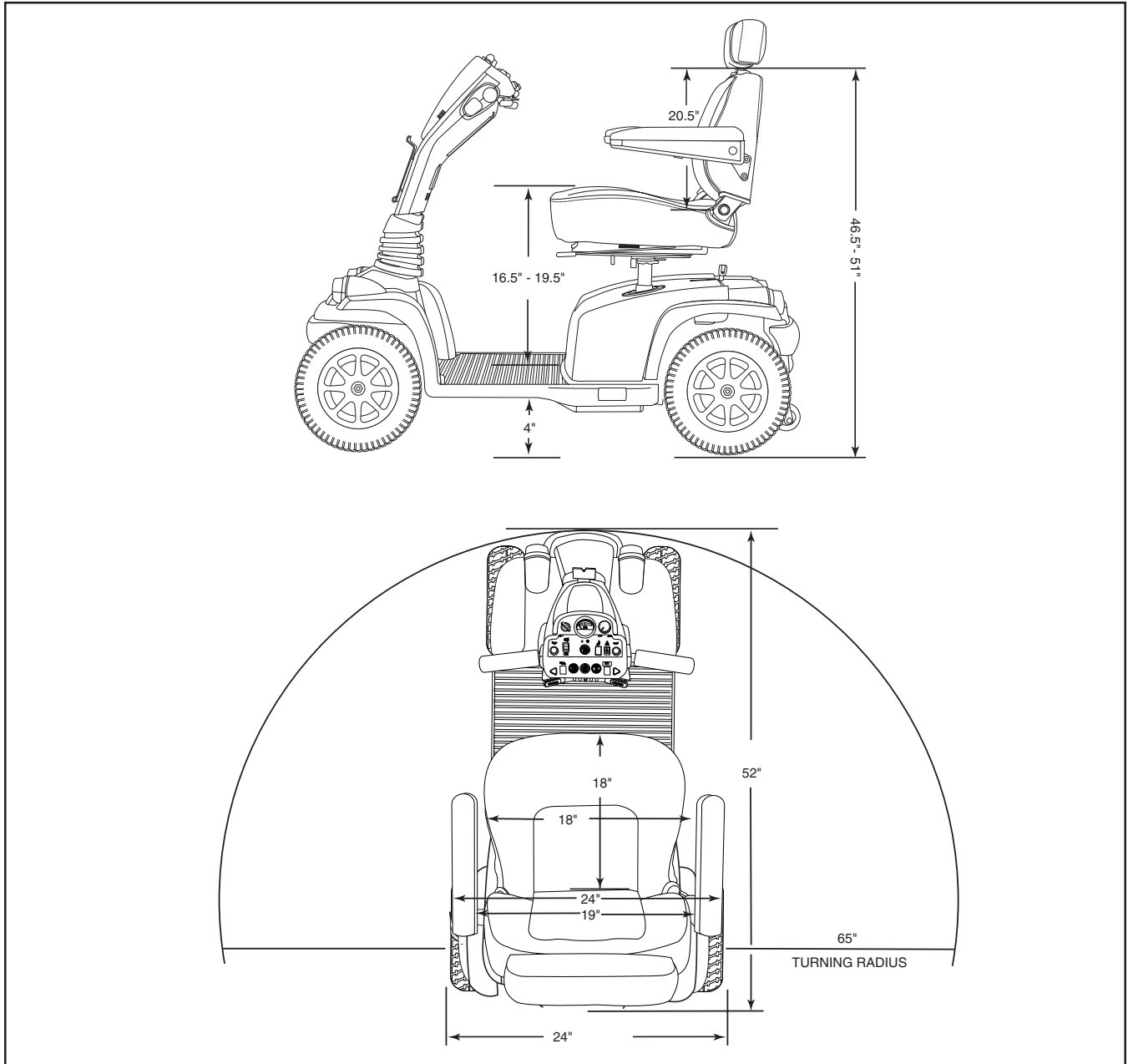

Figure 4. Hurricane Dimensions

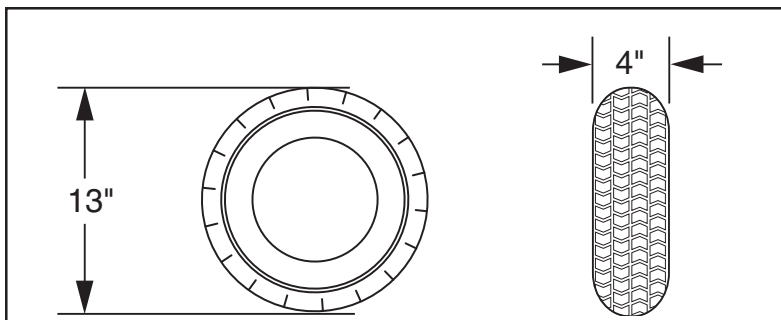

Figure 4A. Hurricane Tire Dimensions (Front and Rear)

## IV. SPECIFICATIONS

<b>Model Number</b>	PMV5001
<b>Colors</b>	Candy Apple Red, Viper Blue, Champagne
<b>Overall Length<sup>2</sup></b>	52 in.
<b>Overall Width<sup>2</sup></b>	24 in.
<b>Total Weight</b>	285 lbs.
<b>Total Weight Without Batteries</b>	209 lbs.
<b>Heaviest Piece When Disassembled</b>	Rear section: 82 lbs.
<b>Turning Radius<sup>2</sup></b>	65 in.
<b>Speed (Maximum)<sup>1</sup></b>	9 mph
<b>Range Per Charge<sup>1</sup></b>	(With NF-22 batteries) Up to 30 miles
<b>Ground Clearance<sup>2</sup></b>	4 in.
<b>Weight Capacity</b>	400 lbs.
<b>Standard Seating</b>	Type: CRS deluxe reclining highback with headrest Weight: 45 lbs. Material: Grey Vinyl or fabric Dimensions: 18 in. width 18 in. depth 20.5 in. height, 27-29 in. with headrest
<b>Drive System</b>	Rear-wheel drive, sealed transaxle, 24 volt DC motor
<b>Dual Braking System</b>	Electronic, regenerative, and electromechanical
<b>Tires</b>	Type: pneumatic front and rear: 4 in. x 13 in.
<b>Battery Requirements<sup>3</sup></b>	Two 12 volt, deep cycle Size: 55 Ah, NF-22 Weight: 38 lbs. each
<b>Battery Charger</b>	Off-board

(1) Varies with user weight, terrain type, battery amp-hour (Ah rating), battery charge, battery condition, and **tire** condition.

(2) Due to manufacturing tolerances and continual product improvement, this specification can be subject to a variance of (+ or -) 3 %.

(3) AGM or Gel-Cell type required. See VI. "Batteries and Charging."

*NOTE: All specifications subject to change without notice.*

# V. YOUR PMV

## TILLER CONSOLE

The tiller console houses all of the controls needed to drive your PMV, including the speed adjustment dial, half/full speed switch, throttle control lever, battery condition meter, lights switch, hazard lights switch, turn signal buttons, status LED, and horn buttons. See figure 5.



**WARNING! Do not expose the tiller console to moisture. In the event that the tiller console does become exposed to moisture, do not attempt to operate your PMV until the tiller console has dried thoroughly.**

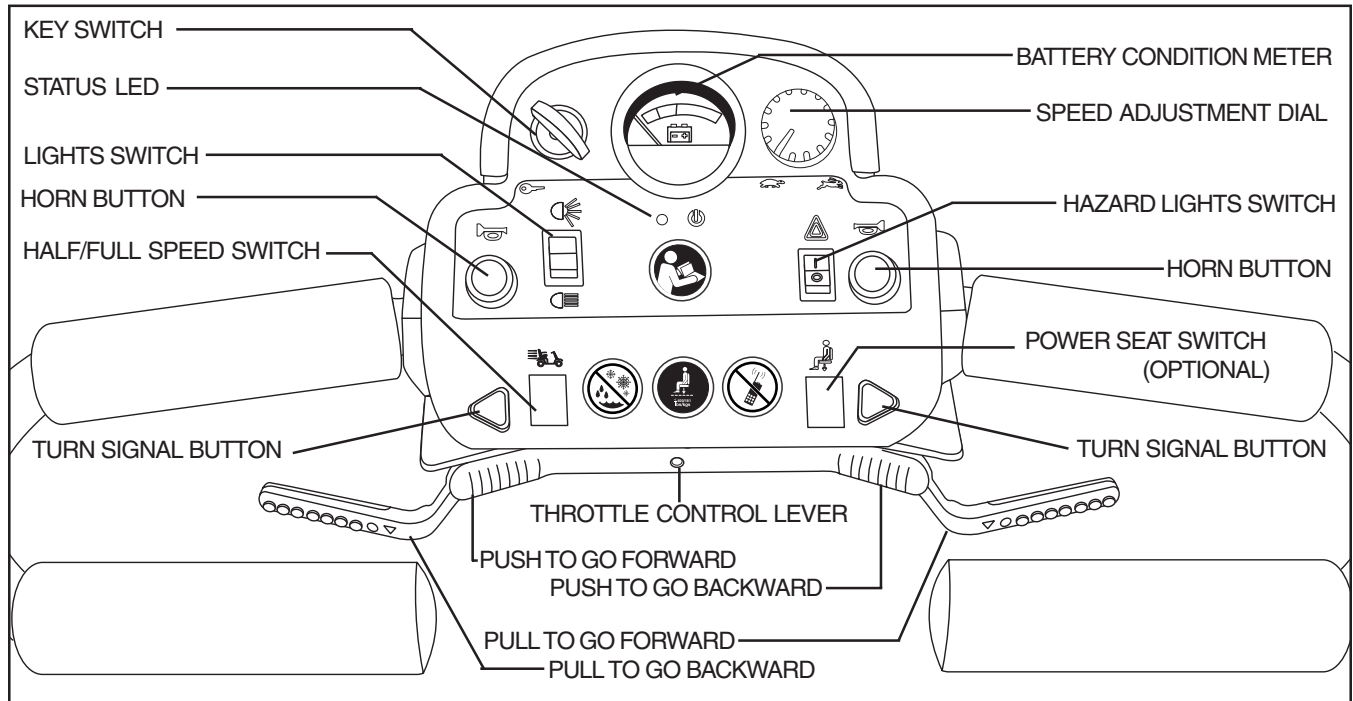

Figure 5. Tiller Console

### Battery Condition Meter

When the key is fully inserted and turned clockwise to power up your PMV, this meter indicates the approximate battery voltage strength. For further information on battery charging, see VI. “Batteries and Charging.”

### Turn Signal Buttons

- Press the appropriate turn signal button once to activate it.
- Your PMV’s turn signals are timed to shut off automatically.

### Hazard Lights Switch

This switch activates the 4-way flashers on your PMV.

- Toggle the switch forward to turn on the flashers.
- Toggle the switch rearward to turn off the flashers.

### Horn Button

Your PMV must be turned on for the horn to be operational.

- This button activates a warning horn.
- Do not hesitate to use the warning horn when doing so may prevent accident or injury.

# V. YOUR PMV

## Key Switch

- Insert the key into the key switch and turn it clockwise to power up (turn on) your PMV.
- Turn the key counterclockwise to power down (turn off) your PMV.



**WARNING! If the key is moved to the “off” position while your PMV is in motion, the electronic brakes engage and your PMV will come to an abrupt stop!**

## Lights Switch

This switch controls your PMV’s lights.

- Toggle the switch forward to turn on your PMV’s rear running lights and front (upper) light.
- Toggle the switch to the middle to turn off the PMV’s lights.
- Toggle the switch rearward to turn on your PMV’s rear running lights, front (upper) and front (lower) lights.



**WARNING! PMV users are required to use their lights when visibility is restricted—day or night. Failure to use the lighting system in periods of poor visibility may result in personal injury.**

## Speed Adjustment Dial

This dial allows you to preselect and limit your PMV’s top speed.

- The image of the tortoise represents the slowest speed setting.
- The image of the hare represents the fastest speed setting.

## Half/Full Speed Switch

- Toggle the switch forward (Full) and your PMV’s approximate maximum speed is 9 mph.
- Toggle the switch rearward (Half) and your PMV’s approximate maximum speed is 4.5 mph.

## Handbrake Lever (Not Shown)

Your PMV is equipped with a handbrake lever, located on the tiller handle. This lever provides you with additional stopping power. Release the throttle control lever and gently squeeze the handbrake lever to come to a stop.

**NOTE: If you do not release the throttle before using the handbrake, your PMV may not come to a complete stop.**

## Throttle Control Lever

This lever allows you to control the forward speed and the reverse speed of your PMV up to the maximum speed you preset with the speed adjustment dial.

To Move Forward use either of the following:

- Use your left thumb to push the left side of the throttle control lever.
- Use your right hand fingers to pull back on the right side of the throttle control lever.

To Move Backward use either of the following:

- Use your right thumb to push the right side of the throttle control lever.
- Use your left hand fingers to pull back on the left side of the throttle control lever.

Release the throttle control lever and allow your PMV to come to a complete stop before engaging the other side of the lever. When the throttle control lever is completely released, it automatically returns to the center “stop” position and engages your PMV’s brakes.

# V. YOUR PMV

## Status LED

The status LED alerts you to electrical problems that may occur with the PMV. The LED remains constantly lit while your PMV is on. If your PMV develops an electrical problem, the status LED will flash a code. See X. “Basic Troubleshooting” for flash codes.

## Tiller Console Fuses

These fuses help protect your PMV’s front lighting, turn signals, and key switch console systems from receiving an overload of electrical current. The fuses used in your PMV are the same type used in automobiles. See figure 5A. See XI. “Care and Maintenance” for fuse replacement.

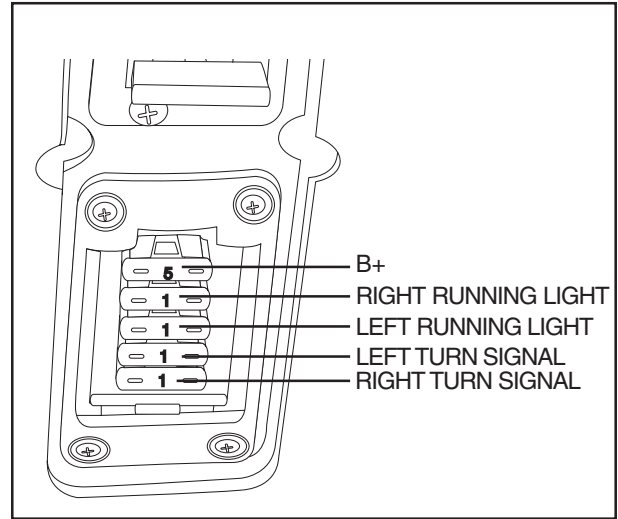

Figure 5A. Tiller Console Fuses

## REAR SECTION

The batteries (not shown), the main circuit breaker (reset button), the manual freewheel lever, the anti-tip wheels, and the motor/transaxle assembly (not shown) are located on the rear section of your PMV. See figure 6.

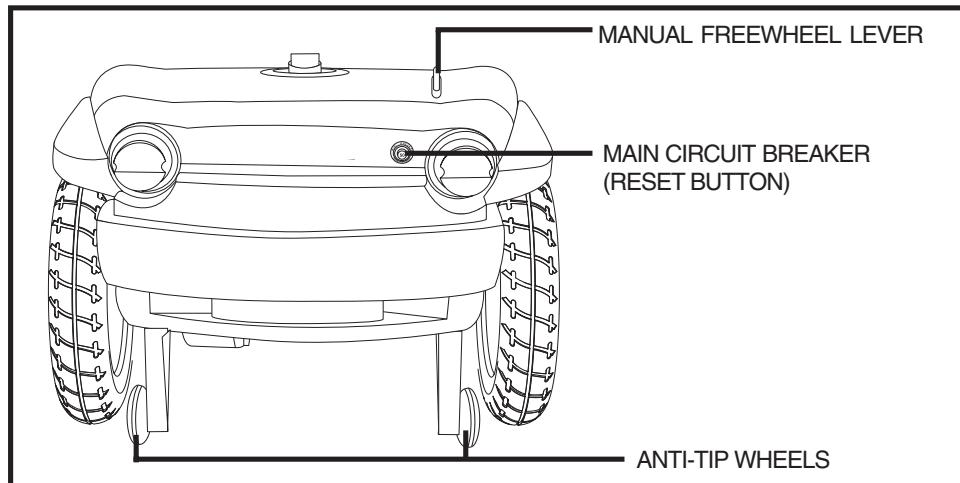

Figure 6. Rear Section

## Anti-Tip Wheels

The anti-tip wheels are an integral and important safety feature of your PMV. Do not, under any circumstances, remove the anti-tip wheels from your PMV.



**WARNING! Do not remove the anti-tip wheels or modify your PMV in any way that is not authorized by Pride.**

## Batteries (Not Shown)

The batteries store electrical energy that powers your PMV. See VI. “Batteries and Charging” for information on how to charge your PMV batteries.

# V. YOUR PMV

## Motor/Transaxle Assembly (Not Shown)

The motor/transaxle assembly is an electromechanical unit that converts electrical energy from your PMV's batteries into the controlled mechanical energy that drives the PMV's wheels.

## Manual Freewheel Lever

Whenever you need or want to push your PMV for short distances, you can put it in freewheel mode.

- Remove the key from the key switch.
- Push forward on the manual freewheel lever to disable the drive system and the brake system.
- You may now push your PMV.
- Pull back on the manual freewheel lever to reengage the drive and the brake systems and take your PMV out of freewheel mode.



**WARNING! When your PMV is in freewheel mode, the braking system is disengaged.**

- **Disengage the drive motors only on a level surface.**
- **Ensure the key is removed from the key switch.**
- **Stand to the side of the PMV to engage or disengage freewheel mode. Never sit on a PMV to do this.**
- **After you have finished pushing your PMV, always return it to the drive mode to lock the brakes.**

***NOTE:** If the PMV is placed in freewheel mode (manual freewheel lever forward) while the key is in the “on” position, the PMV will not run until the manual freewheel lever is pushed backward and the key is turned to the “off” position, then back to the “on” position.*

## Main Circuit Breaker (Reset Button)

When the voltage in the batteries becomes low or your PMV is heavily strained because of excessive loads, the main circuit breaker may trip to protect the motor and electronics from damage. When the breaker trips, the entire electrical system shuts down.

- The reset button pops out when the breaker trips.
- Allow a minute or so for the electronics to “rest.”
- Push in the reset button to reset the breaker.
- If the breaker trips frequently, you may need to charge the batteries more often or have your authorized Pride Provider perform a load test on the batteries.
- If the main circuit breaker trips repeatedly, see your authorized Pride Provider for service.

## VI. BATTERIES AND CHARGING

Your PMV requires two long-lasting, 12-volt, deep-cycle batteries that are sealed and maintenance free. They are recharged by an off-board charging system.

- Charge your PMV's batteries prior to using it for the first time.
- Keep the batteries fully charged to keep your PMV running smoothly.

### READING YOUR BATTERY VOLTAGE

The battery condition meter on the tiller console indicates the approximate strength of your batteries using a color code. See figure 7. Green indicates fully charged batteries, yellow a draining charge, and red indicates that an immediate recharge is necessary.

**NOTE:** To ensure the highest accuracy, the battery condition meter should be checked while operating your PMV at full speed on a dry, level surface.

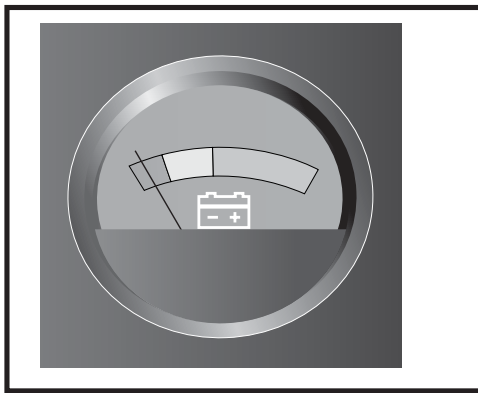

Figure 7. Battery Condition Meter

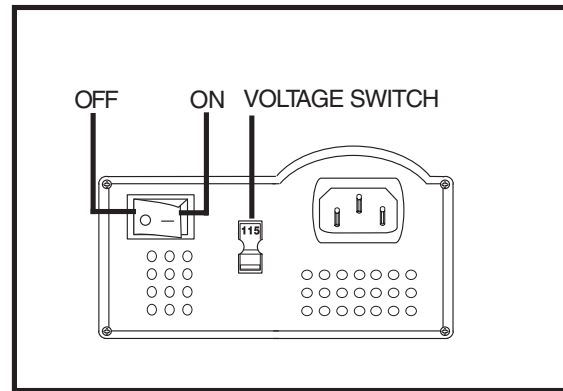

Figure 8. Charger On/Off and Voltage Switches

The off-board charger supplied with your PMV is equipped with a 115/230 voltage switch. Confirm that this switch is in the proper position for your locality. If you are not sure what the voltage is in your country, contact your local electricity provider before inserting the charger power cord plug into your electrical outlet. If the setting is incorrect, the charger will not function properly. Slide the voltage switch to the prescribed position. See figure 8.

### CHARGING YOUR BATTERIES



**PROHIBITED!** Removal of grounding prong can create electrical hazard. If necessary, properly install an approved 3-pronged adapter to an electrical outlet having 2-pronged plug access.



**PROHIBITED!** Never use an extension lead to plug in your battery charger. Plug the charger directly into a properly wired standard electrical outlet.



**MANDATORY!** Read the battery charging instructions in this manual and in the manual supplied with the battery charger before charging the batteries.



**WARNING!** Explosive gases may be generated while charging the batteries. Keep the PMV and battery charger away from sources of ignition such as flames or sparks and provide adequate ventilation when charging the batteries.



## VI. BATTERIES AND CHARGING

**WARNING!** You must recharge your PMV's batteries with the supplied off-board charger. Do not use an automotive-type battery charger.

**WARNING!** Inspect the battery charger, wiring and connectors for damage before each use. Contact your authorized Pride Provider if damage is found.



**WARNING!** Do not attempt to open the battery charger case. If the battery charger does not appear to be working correctly, contact your authorized Pride Provider.

**WARNING!** If the battery charger is equipped with cooling slots, then do not attempt to insert objects through these slots.



**WARNING!** Do not allow unsupervised children to play near the PMV while the batteries are charging. Pride recommends that you do not charge the batteries while the PMV is occupied.



**WARNING!** If your battery charger has not been tested and approved for outdoor use, then do not expose it to adverse or extreme weather conditions. If the battery charger is exposed to adverse or extreme weather conditions, then it must be allowed to adjust to the difference in environmental conditions before use indoors. Refer to the manual supplied with the battery charger for more information.



Follow these easy steps to charge your batteries safely:

**NOTE:** Ensure that both ends of the charger power cord are clean and dry before plugging the charger power cord into the off-board charger port or the wall socket.

1. Position your PMV close to a standard electrical outlet.
2. Remove the key from the key switch.
3. Make certain that the manual freewheel lever is in the drive position.
4. Plug the 3-pin charger power cord into the off-board charger port. **See figures 9 and 10.**
5. Extend the charger power cord and plug it into the electrical outlet.
6. Turn the charger on. **See figure 8.**
7. When the batteries are fully charged, turn the charger off and unplug the charger power cord from the electrical outlet and then from the off-board charger port.

The LED lights on the charger indicate different charger conditions at various times: charger power on, charging in progress, charging complete. Refer to the label on the charger for a complete explanation of these indicators.

**NOTE:** There is a charger inhibit function on your PMV. The PMV will not run and the battery condition meter will not operate while the batteries are charging.

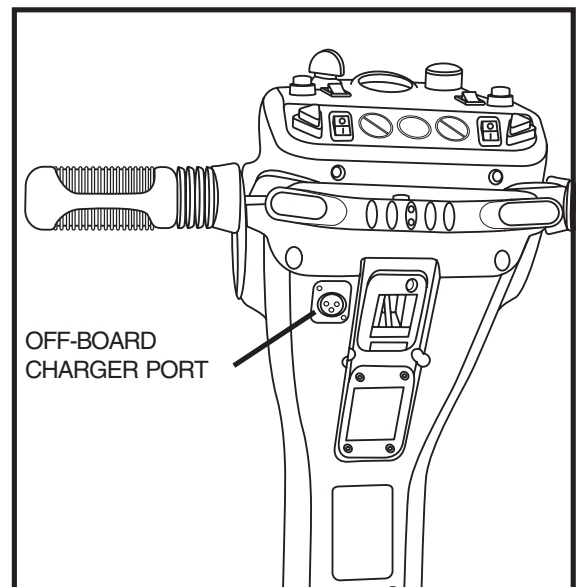

Figure 9. Off-Board Charger Port

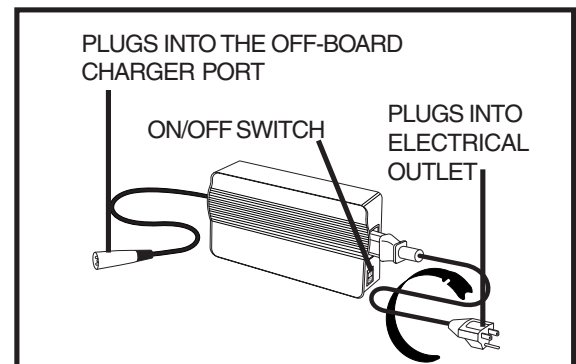

Figure 10. Off-Board Charger

# VI. BATTERIES AND CHARGING

## FREQUENTLY ASKED QUESTIONS

### **How does the charger work?**

When your PMV's battery voltage is low, the charger works harder, sending more electrical current to the batteries to bring up their charge. As the batteries approach a full charge, the charger sends less and less electrical current. When the batteries are fully charged, the current sent from the charger is at nearly zero amperage. Therefore, when the charger is plugged in, it maintains the charge on your PMV's batteries, but does not overcharge them. We do not recommend that you charge your PMV's batteries for more than 24 consecutive hours.

### **What if my PMV's batteries won't charge?**

- Ensure the red (+) and black (-) battery cables are connected properly to the battery terminals.
- Ensure both battery harnesses that extend from the batteries are plugged into their mating harness leading to the charger.
- Ensure both ends of the charger power cord are inserted fully.

### **Can I use a different charger?**

For the safest, most efficient, and balanced charging of your PMV's batteries, we prefer and highly recommend simultaneous charging of both batteries with the supplied off-board battery charger.

### **How often must I charge the batteries?**

Two major factors must be considered when deciding how often to charge your PMV's batteries:

- All day PMV use on a daily basis.
- Infrequent or sporadic PMV use.

With these considerations in mind, you can determine how often and for how long you should charge your PMV's batteries. We designed the battery charger so that it will not overcharge your PMV's batteries. However, you may encounter some problems if you do not charge your batteries often enough and if you do not charge them on a regular basis. Following the guidelines below will provide safe and reliable battery operation and charging.

- If you use your PMV daily, charge its batteries as soon as you finish using it for the day. Your PMV will be ready each morning to give you a full day of service. We recommend that you charge your PMV's batteries for 8 to 14 hours after daily use.
- If you use your PMV once a week or less, charge its batteries at least once a week for 12 to 14 hours at a time.
- Keep your PMV's batteries fully charged.
- Avoid deeply discharging your PMV's batteries.

### **How can I ensure maximum battery life?**

Fully charged deep-cycle batteries provide reliable performance and extended battery life. Keep your PMV's batteries fully charged whenever possible. Batteries that are regularly and deeply discharged, infrequently charged, or stored without a full charge may be permanently damaged, causing unreliable performance and limited service life.

## VI. BATTERIES AND CHARGING

### How can I get maximum range or distance per charge?

Rarely will you have ideal driving conditions—smooth, flat, hard driving surfaces with no wind or curves. Often, you will face hills, pavement cracks, uneven and loosely packed surfaces, curves, and wind, all of which affect the distance or running time per battery charge. Below are a few suggestions for obtaining the maximum range per battery charge.

- Always fully charge your PMV's batteries prior to daily use.
- Maintain **30-35 psi** in each tire.
- Plan your route ahead to avoid as many hills, cracked, broken, or soft surfaces as possible.
- Limit your baggage weight to essential items.
- Try to maintain an even speed while your PMV is in motion.
- Avoid stop-and-go driving.

### What type and size of battery should I use?

We recommend deep-cycle batteries that are sealed and maintenance free. Both AGM and Gel Cell are deep-cycle batteries that are similar in performance. Do not use wet-cell batteries, which have removable caps.



**WARNING! Corrosive chemicals are contained in batteries. Use only AGM or Gel-Cell batteries to reduce the risk of leakage or explosive conditions.**

*NOTE: Sealed batteries are not serviceable. Do not remove the caps.*

### How do I change a battery?



**WARNING! Contact your Pride Provider if you have any questions regarding the batteries in your PMV.**



**WARNING! Battery posts, terminals and related accessories contain lead and lead compounds. Wear goggles and gloves when handling batteries and wash hands after handling.**



**WARNING! Always use two batteries of the exact same type, chemistry and amp-hour (Ah) capacity. Refer to the specifications table in this manual and in the manual supplied with the battery charger for recommended type and capacities.**



**WARNING! Do not replace the batteries while the PMV is occupied.**

**WARNING! The batteries on your PMV should only be serviced or replaced by an authorised Pride Provider or a qualified technician.**

1. Remove the seat and rear shroud.
2. Disconnect the battery tie-down strap.
3. Disconnect the T-handle battery harness.
4. Disconnect the battery cables from the battery terminals.
5. Remove the old batteries.
6. Place new batteries into the battery wells.
7. Connect the red battery cable to the positive (+) battery terminal.
8. Connect the black battery cable to the negative (-) battery terminal.
9. Reconnect the T-handle battery harness.
10. Reconnect the battery tie-down strap.
11. Reinstall the rear shroud and seat.

## VI. BATTERIES AND CHARGING

### **BATTERY DISPOSAL AND RECYCLING**

If you encounter a damaged or cracked battery, immediately enclose it in a plastic bag and call your authorized Pride Provider for instructions on disposal. Your authorized Pride Provider will also have the necessary information on battery recycling, which is our recommended course of action.

### **Why do my new batteries seem weak?**

Deep-cycle batteries employ a different chemical technology than that used in car batteries, nickel-cadmium batteries (nicads), and other common battery types. Deep-cycle batteries are specifically designed to provide power, drain down their charge, and then accept a relatively quick recharge.

We work closely with our battery manufacturer to provide batteries that best suit your PMV's specific electrical demands. Fresh batteries arrive daily at Pride and are shipped fully charged to our customers. During shipping, the batteries may encounter temperature extremes that can influence their initial performance. Heat diminishes the charge on the battery; cold slows the available power and extends the time needed to recharge the battery.

It may take a few days for the temperature of your PMV's batteries to stabilize and adjust to their new room or ambient temperature.

More importantly, it takes a few charging cycles (partial draining followed by full recharging) to establish the critical chemical balance that is essential to a deep-cycle battery's peak performance and long life.

Follow these steps to properly break in your PMV's new batteries for maximum efficiency and service life.

1. Fully recharge any new battery prior to its initial use. This charging cycle brings the battery up to about 88% of its peak performance level.
2. Operate your new PMV in familiar and safe areas. Drive slowly at first, and do not travel too far from your home or familiar surroundings until you have become accustomed to your PMV's controls and have properly broken in your PMV's batteries.
3. Fully recharge the batteries. They should be at over 90% of their peak performance level.
4. Operate your PMV again.
5. Fully recharge the batteries again.
6. After four or five charging cycles, the batteries are able to receive a charge of 100% of their peak performance level and are able to last for an extended period of time.

### **What about public transportation?**

If you intend to use public transportation with your PMV, you must contact the transportation provider in advance to determine their specific requirements.

# VII. OPERATION

## BEFORE GETTING ON YOUR PMV

- Have you fully charged the batteries? See VI. “Batteries and Charging.”
- Is the manual freewheel lever in the drive (backward) position? Never leave the manual freewheel lever pushed forward unless you are manually pushing your PMV.

## GETTING ONTO YOUR PMV



**WARNING! Never attempt to get onto or off of your PMV without first removing the key from the key switch. This will prevent the PMV from moving if accidental throttle control lever contact is made.**

1. Make certain that the key is removed from the key switch.
2. Stand at the side of your PMV.
3. Disengage the seat lock lever and rotate the seat until it is facing you.
4. Make certain that the seat is locked securely in position.
5. Position yourself comfortably and securely in the seat.
6. Disengage the seat lock lever and rotate the seat until you are facing forward.
7. Make certain that the seat is locked securely in position.
8. Make certain that your feet are safely on the floorboard.

## PRE-RIDE ADJUSTMENTS AND CHECKS

- Are you positioned comfortably in the seat? See “Getting Onto Your PMV,” above.
- Is the seat at the proper height? See VIII. “Comfort Adjustments.”
- Is the seat locked securely in place? See VIII. “Comfort Adjustments.”
- Is the tiller at a comfortable setting and locked securely in place? See VIII. “Comfort Adjustments.”
- Is the key fully inserted into the key switch and turned clockwise to the “on” position? See V. “Your PMV.”
- Does the PMV’s horn work properly?
- Is your proposed path clear of people, pets, and obstacles?
- Have you planned your route to avoid adverse terrain and as many inclines as possible?

## OPERATING YOUR PMV

**WARNING! The following can adversely affect steering and stability while operating your PMV:**



- **Holding onto or attaching a leash to walk your pet.**
- **Carrying passengers (including pets).**
- **Hanging any article from the tiller.**
- **Towing or being pushed by another motorized vehicle.**

**Such practices could cause loss of control and/or tipping resulting in personal injury and/or damage to your PMV.**

Keep both hands on the tiller and your feet on the floorboard at all times while operating your PMV. This driving position gives you the most control over your vehicle.

- Set the speed adjustment dial to your desired speed.
- Press or pull the appropriate side of the throttle control lever.
- The electromechanical disc park brake automatically disengages and the PMV accelerates smoothly to the speed you preselected with the speed adjustment dial.

## VII. OPERATION

- Pull on the left handgrip to steer your PMV to the left.
- Pull on the right handgrip to steer your PMV to the right.
- Move the tiller to the center position to drive straight ahead.
- To stop, slowly release the throttle control lever. After you release the throttle control lever, gently squeeze the handbrake (if equipped) to come to a complete stop. The electronic brakes will automatically engage when your PMV comes to a stop.

**NOTE:** *Your PMV's reverse speed is slower than that of the forward speed you preset with the speed adjustment dial.*

### GETTING OFF OF YOUR PMV

1. Bring your PMV to a complete stop.
2. **Remove the key from the key switch.**
3. Disengage the seat lock lever and rotate the seat until you are facing toward the side of your PMV.
4. Make certain that the seat is locked securely in position.
5. Carefully and safely get out of the seat and stand to the side of your PMV.
6. You can leave the seat facing to the side to facilitate boarding your PMV next time.

### POWER DOWN TIMER FEATURE

Your PMV is equipped with an energy saving automatic power down timer feature designed to preserve your PMV's battery life. If you mistakenly leave the key in the key switch and in the "on" position but do not use your PMV for approximately 20 minutes, the PMV's controller shuts down automatically. Although the controller is shut down, power will still be supplied to the PMV's lighting system.

If the power down timer feature takes effect, perform the following steps to resume normal operation.

1. Turn the key to the "off" position.
2. Turn the key back to the "on" position.

# VIII. COMFORT ADJUSTMENTS



**WARNING! Remove the key from the key switch before adjusting the tiller or the seat. Never attempt to adjust the tiller or the seat while the PMV is in motion.**

## TILLER ANGLE ADJUSTMENT

Your PMV is equipped with a pivoting tiller that allows adjustment to several positions from the PMV deck to the farthest forward stop.

1. Lift the tiller adjustment lever. See figure 11.
2. Move the tiller to a comfortable position.
3. Release the tiller adjustment lever to secure the tiller in position.

## SEAT ROTATION

The seat lock lever will lock the seat into several positions.

1. Push forward on the seat lock lever to unlock the seat. See figure 12.
2. Rotate the seat to the desired position.
3. Release the lever to lock the seat into place.

## FRONT-TO-BACK SEAT ADJUSTMENT

You can reposition the PMV's seat forward or rearward to adjust the distance between the seat and the tiller. See figure 12.

1. Move the seat sliding lever outward.
2. While holding the lever out, slide the seat forward or rearward.
3. Release the seat sliding lever once the seat is in the desired position.

## SEATBACK ADJUSTMENT



**WARNING! Do not operate your PMV with the seatback in a reclined position.**

**WARNING! Always keep your back pressed firmly against the seatback while adjusting the angle.**

To adjust your PMV's reclining seat, perform these steps. See figure 12A.

1. With your back pressed up against the seatback, lift up on the seatback adjustment lever and lean forward or rearward to adjust the seatback angle.
2. Release the seatback adjustment lever once the seat is in a comfortable riding position.

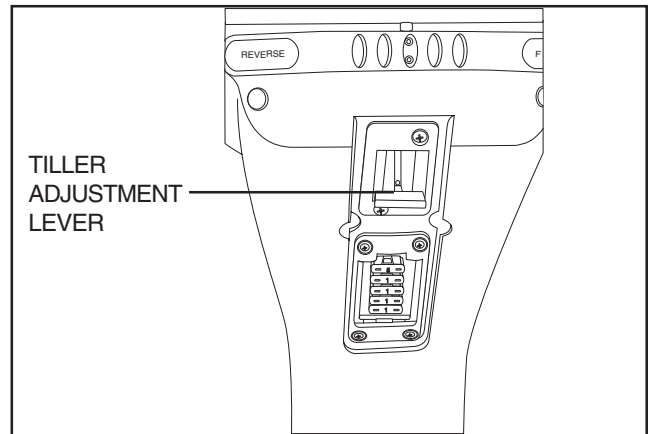

Figure 11. Tiller Adjustment

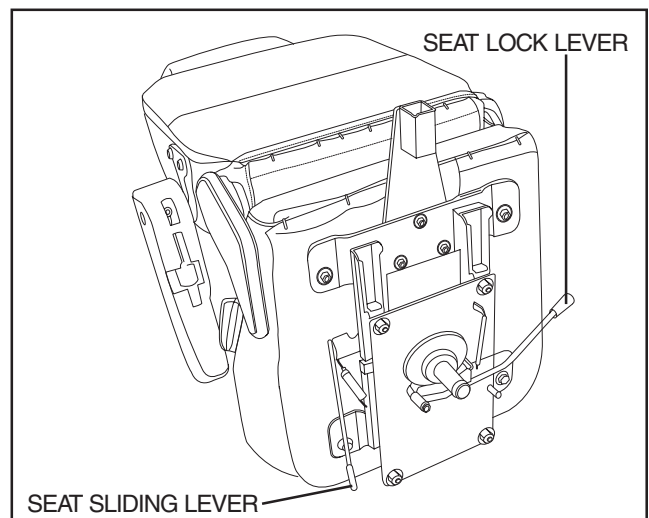

Figure 12. Seat Adjustment

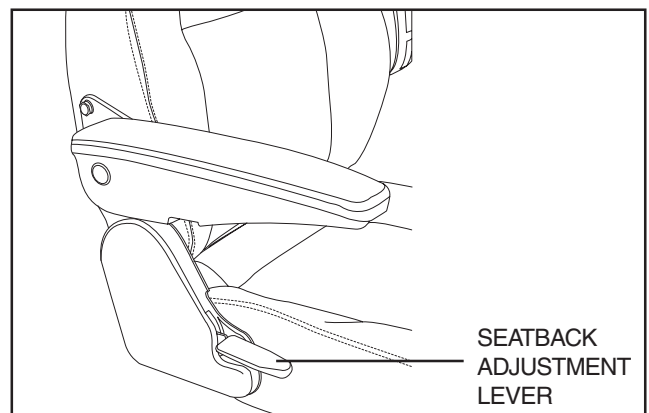

Figure 12A. Seatback Adjustment

## VIII. COMFORT ADJUSTMENTS

### ARMREST ANGLE ADJUSTMENT

The armrest angle of your PMV can be adjusted upward or downward by turning the adjustment dial. See figure 12B.

**NOTE:** *Pivot the armrests upward to make getting onto and off of your PMV easier.*

### SEAT HEIGHT ADJUSTMENT

You can change the seat height to one of three positions in 1-in. increments. See figure 13.

#### Changing the seat height:

1. Remove the seat and shroud from your PMV. See IX. "Disassembly and Assembly."
2. Loosen the seat height adjustment nut and remove it from the bolt, then remove the bolt.
3. Loosen the clamp-action bolt.
4. Raise or lower the upper seat post to the desired seat height.
5. While holding the upper seat post at that height, align the locating holes of the upper seat post with those of the lower seat post.
6. Insert the seat height adjustment bolt through the locating holes of both the upper and lower seat posts. Reinstall the nut and tighten.
7. Tighten the clamp-action bolt
8. Reinstall the rear shroud and the seat.

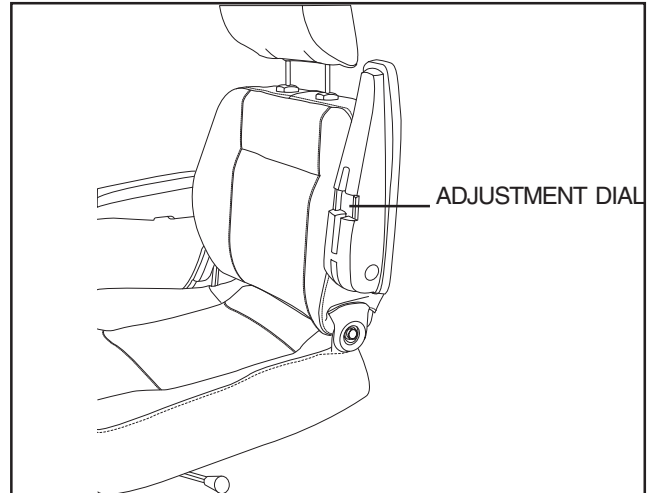

Figure 12B. Armrest Angle Adjustment

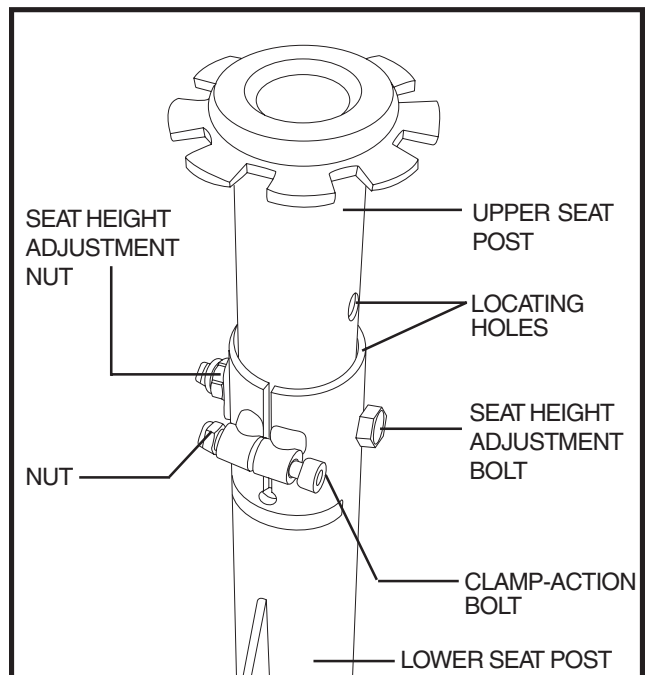

Figure 13. Seat Height Adjustment



# VIII. COMFORT ADJUSTMENTS

## POWER SEAT (OPTIONAL)

Your PMV may be equipped with a power seat option, a power seat switch will be located on the tiller console. See figure 5. The power seat will be equipped with one of two operating systems. Refer to figures 14 and 15 to determine which system your PMV uses and follow the appropriate instructions for safe operation.



**WARNING! The power seat is intended for operation only while your PMV is stationary and on a level surface. Its purpose is to aid you in reaching objects. Drive your PMV only with the power seat in the lowest position. Driving the PMV with power seat elevated could result in personal injury, equipment and/or property damage.**

**Strict adherence to the following safety rules is vital to your safety:**

- **Operate the power seat only while completely stationary on level ground.**
- **Do not press the throttle control lever and the power seat switch at the same time.**
- **Do not operate your PMV with the power seat elevated. Operate the PMV only with the power seat fully retracted (in the lowest position).**
- **Never place your PMV in freewheel mode with the power seat elevated.**
- **Use extreme caution when reaching for objects with your power seat elevated. Do not overextend or attempt to pick up objects that might affect your balance.**
- **Do not attempt to raise or lower the seat while in motion.**

Before operating the power seat, ensure your PMV is level and stationary and the speed adjustment dial is set to the slowest setting.

### System 1 - Operation using power seat switch and throttle control lever:

1. Release the throttle control lever.
2. Toggle the power seat switch located on the tiller console to the “on” position. See figure 14.
3. To raise the power seat, operate your throttle control lever in the forward direction.
4. Release the throttle control lever when you have attained your desired height.
5. To lower the power seat, operate your throttle control lever in the reverse direction.
6. Ensure your seat is in the lowest position and that you have fully released the throttle control lever.
7. Toggle “off” the power seat switch before you attempt to drive your PMV again.

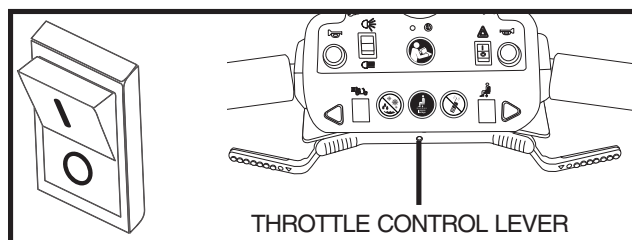

Figure 14. Power Seat Switch (With Vertical Line And Circle) Used In Conjunction With Throttle Control Lever to Activate The Power Seat Actuator (Switch Shown In The “Off” Position)

### System 2 - Operation with power seat switch only:

1. To raise the power seat, press and hold the upper part of the switch. Release the switch when you have attained your desired height or until reaching the highest position. See figure 15.
2. To lower the power seat, press and hold the lower part of the switch. Release the switch when you have attained your desired height or until reaching the lowest position.

**NOTE: The PMV must be stopped in order for the power seat to be operated. If the power seat switch is pressed while the PMV is in motion, the PMV will slow and come to a stop. The PMV may also produce a fault code indicated by the Status LED on the console. If a fault code occurs, you will need to turn the PMV’s power off then back on again before proceeding.**

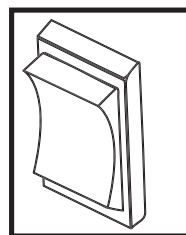

Figure 15. Power Seat Switch (With No Markings)-Activates The Power Seat Actuator

# IX. DISASSEMBLY AND ASSEMBLY

## DISASSEMBLY

You can disassemble the PMV into seven pieces: the seat, the front section, the rear section, the rear shroud, the basket, and the batteries. See figure 14. No tools are required to disassemble or assemble your PMV. Since the disassembled sections of the PMV take up more floor space than the assembled unit, place the PMV on a level, dry surface with sufficient room to move the parts around. You will need about five feet in all directions. Keep in mind that you may need assistance to lift some of the PMV components.

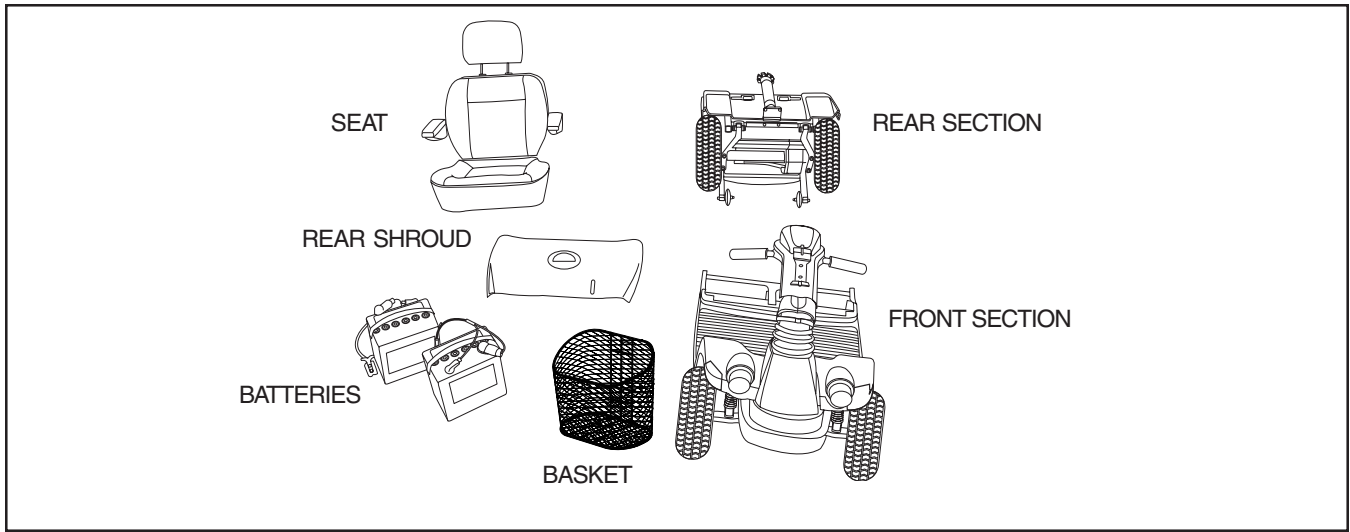

Figure 16. The Hurricane Disassembled



**WARNING! Lifting weight beyond your physical capability may result in personal injury. Ask for assistance when necessary while disassembling or assembling your PMV.**

1. Place the manual freewheel lever in the drive position.
2. Lift the seat up and off the PMV.
3. Gently pull the shroud up and off of the rear section of the PMV.
4. Disconnect the battery strap.
5. Unplug both T-handle battery harnesses. See figure 17.
6. Remove the batteries.
7. Unplug the front-to-rear harness. See figure 17.



**WARNING! Failure to unplug both T-handle battery harnesses and the front-to-rear harness prior to separating the front and rear sections could result in permanent damage to the PMV.**

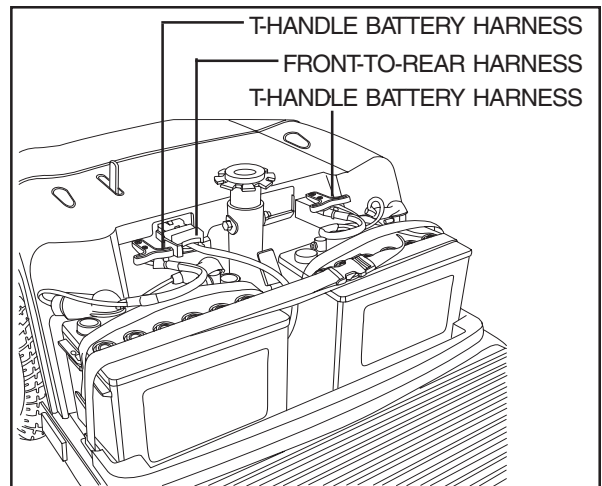

Figure 17. Harness Connections

# IX. DISASSEMBLY AND ASSEMBLY

## Toggle Latch Release

1. Push in the toggle latch release button while pulling back the toggle latch. See figures 16 and 18A.
2. Position the toggle latch buckle over the top of the toggle latch. See figure 18B.

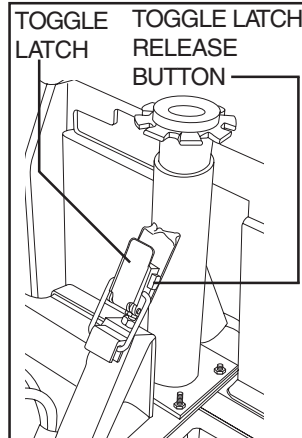

Figure 18. Toggle Latch (Latched)

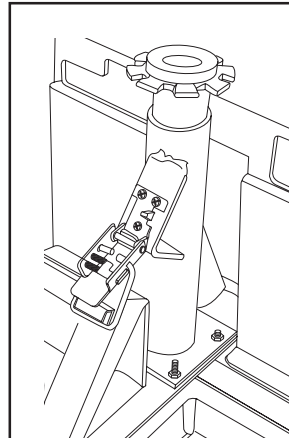

Figure 18A. Toggle Latch (Unlatched)

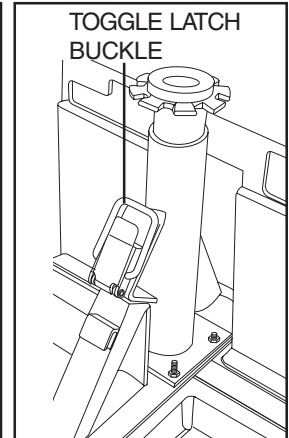

Figure 18B. Buckle Secured

## Frame Separation

1. Lower the tiller to the PMV floorboard.
2. Push back on the seat post to pivot the PMV's rear section rearwards until the rear section is standing vertically on its bumper. See figure 19.
3. Lift the front section up until the lower pegs are no longer in the slots. See figure 20.
4. Carefully move the front section away from the rear section.

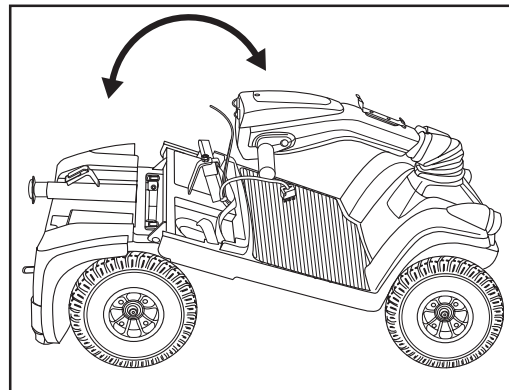

Figure 19. Frame Positioning

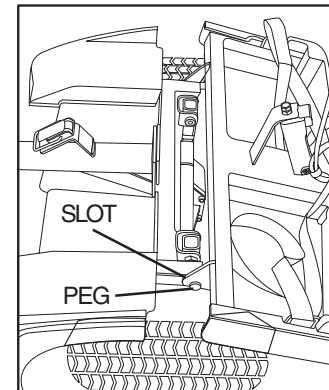

Figure 20. Separating The Frame Sections

## ASSEMBLY

1. Position the front and rear sections of your PMV as shown in figure 21.
2. Align the lower slots of the front section with the corresponding pegs on the front of the rear section. See figure 21.



**WARNING! Position the front-to-rear harness so it won't become pinched between the frame halves when pivoting the rear section forward. See figure 21.**

3. Holding the seat post, slowly pivot the rear section forward until the curved locking brackets are fully connected onto the top rear pegs. See figure 19.
4. Raise the tiller.
5. Latch the toggle latch. See figure 18A.
  - Lower the toggle latch buckle.
  - Push back on the toggle latch so it locks into place.
6. Reinstall the batteries into the battery wells and reconnect the battery strap.
7. Connect the front-to-rear harness and both T-handle battery harnesses.
8. Reinstall the shroud.
9. Reinstall the seat, and lock it into place.

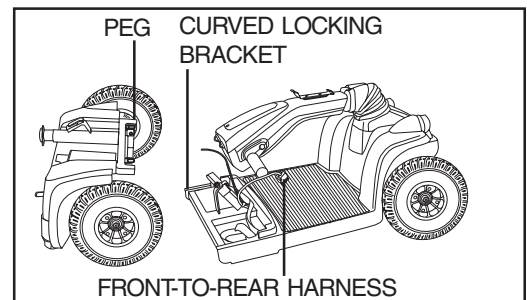

Figure 21. Frame Sections

# X. BASIC TROUBLESHOOTING

Any electromechanical device occasionally requires some troubleshooting. However, most of the problems that may arise can usually be solved with a bit of thought and common sense. Many of these problems occur because the batteries are not fully charged or because the batteries are worn down and can no longer hold a charge.

## DIAGNOSTIC FLASH CODES

The diagnostic flash codes for your PMV are designed to help you perform basic troubleshooting quickly and easily. A diagnostic flash code will flash from the status LED in the event one of the conditions listed below develops.

**NOTE:** *Your PMV will not run unless the flash code condition is resolved and the PMV has been turned off, then turned back on.*

FLASH CODE	CONDITION	SOLUTION
(1) ■	Battery voltage is too low to operate the PMV.	Check connections between batteries and controller.
(2) ■■	Motor disconnected.	Check all connections to the motor.
(3) ■■■	Motor wiring fault.	Call your authorized Pride Provider for assistance.
(6) ■■■■■■	PMV won't operate because the charger is attached or the power seat switch was pressed while the scooter was in motion.	Unplug the charger power cord from the off-board charger port. Restart your PMV by turning your scooter off, then back on.
(7) ■■■■■■■■	Throttle potentiometer fault.	Call your authorized Pride Provider for assistance.
(8) ■■■■■■■■■■	Internal controller fault.	Call your authorized Pride Provider for assistance.
(9) ■■■■■■■■■■	Brake fault—your PMV was left in freewheel mode.	Turn the PMV key to the “off” position, then push the manual freewheel lever to the drive position, and restart your PMV.
(10) ■■■■■■■■■■■■	Excess voltage to controller.	Check all connections between the batteries and the controller. If condition persists, contact your authorized Pride Provider for assistance.

### What if all the systems on my PMV seem to be “dead”?

- Make certain that the key is in the “on” position.
- Check that the batteries are fully charged.
- Push in the main circuit breaker reset button. See V. “Your PMV.”
- Make certain that both T-handle battery harnesses are firmly connected to the rear section and to the battery terminals. See IX. “Disassembly and Assembly.”
- Make sure that the front-to-rear harness is firmly connected to the rear section. See IX. “Disassembly and Assembly.”
- Be sure the power down timer feature hasn't been activated. See VII. “Operation.”
- Check the 3-amp fuse located on the lower portion of the tiller console. See XI. “Care and Maintenance” for fuse replacement.

### What if my PMV does not move when I engage the throttle control lever?

- When the manual freewheel lever is pushed forward, the brakes are disengaged and all power to the motor/transaxle assembly is cut.
- Pull back on the manual freewheel lever, turn the PMV off, then back on to return to normal operation.

## X. BASIC TROUBLESHOOTING

### **What if the main circuit breaker repeatedly trips?**

- Charge the PMV's batteries more frequently. See VI. "Batteries and Charging."
- If the problem continues, have both of your PMV's batteries load tested by your authorized Pride Provider.
- You may also perform the load test yourself. Battery load testers are available at most automotive parts stores.
- Follow the directions supplied with the load tester.
- See IV. "Specifications" for information about your PMV's battery type.

### **What if the battery condition meter dips way down and the motor surges or hesitates when I engage the throttle control lever?**

- Fully charge your PMV's batteries. See VI. "Batteries and Charging."
- Have your authorized Pride Provider load test each battery.
- Or, see the previous troubleshooting question for load testing the batteries yourself.

If you experience any problems with your PMV that you are not able to solve, immediately contact your authorized Pride Provider for information, maintenance, and service.

# XI. CARE AND MAINTENANCE

Your PMV requires a minimal amount of care and maintenance. If you do not feel confident in your ability to perform the maintenance listed below, you may schedule inspection and maintenance at your authorized Pride Provider. The following areas require periodic inspection and/or care and maintenance.

## TIRE PRESSURE

- If equipped with pneumatic tyres, always maintain a proper **30-35 psi** tire pressure.



**WARNING! It is important that 30-35 psi tire pressure be maintained in pneumatic tyres at all times. Do not underinflate or overinflate your tyres. Low pressure may result in loss of control, and overinflated tyres may burst. Failure to maintain 30-35 psi tire pressure in pneumatic tyres at all times may result in tire and/or wheel failure.**

- Regularly inspect your PMV's tyres for signs of wear.

## WHEEL REPLACEMENT

If your PMV is equipped with pneumatic tires and you have a flat tire, you can have the tube replaced. If your PMV is equipped with a solid tire insert, either the solid insert or the entire wheel must be replaced depending on model. Contact your authorized Pride Provider for information regarding replacement wheels for your PMV.

**WARNING! Wheels on your PMV should only be serviced/replaced by an authorised Pride Provider or qualified technician.**



**WARNING! Completely deflate pneumatic tires before dismantling the rim or attempting repair.**

**WARNING! When changing a tire, remove only the center lug nut, then remove the tire. If any further disassembly is required, deflate the tire completely or it may explode.**

## EXTERIOR SURFACES

Bumpers, tyres, trim, and the tiller boot can benefit from an occasional application of a rubber or vinyl conditioner.



**WARNING! Do not use a rubber or vinyl conditioner on the PMV's vinyl seat or tire tread, as they will become dangerously slippery.**

## CLEANING AND DISINFECTION

- Use a damp cloth and mild, non-abrasive cleanser to clean the plastic and metal parts of your PMV. Avoid using products that may scratch the surface of your PMV.
- If necessary, clean your product with an approved disinfectant. Make sure the disinfectant is safe for use on your product before application.



**WARNING! Follow all safety instructions for the proper use of the disinfectant and/or cleaning agent before applying it to your product. Failure to comply may result in skin irritation or premature deterioration of upholstery and/or PMV finishes.**

## BATTERY TERMINAL CONNECTIONS

- Make certain that the terminal connections remain tight and uncorroded.
- The batteries must sit flat in the battery wells.
- The battery terminals should face the rear of the PMV.

# XI. CARE AND MAINTENANCE

## WIRING HARNESSES

- Regularly check all wiring connections.
- Regularly check all wiring insulation, including the charger power cord, for wear or damage.
- Have your authorized Pride Provider repair or replace any damaged connector, connection, or insulation that you find before using your PMV again.



**WARNING! Even though the PMV has passed the necessary testing requirements for ingress of liquids, you should keep electrical connections away from sources of dampness, including direct exposure to water or bodily fluids and incontinence. Check electrical components frequently for signs of corrosion and replace as necessary.**

## ABS PLASTIC SHROUDS

- The front tiller shroud, front shroud, and the rear shroud are formed from durable ABS plastic and are coated with an advanced formula urethane paint.
- A light application of car wax will help the shrouds retain their high gloss.

## AXLE BEARINGS AND THE MOTOR/TRANSAXLE ASSEMBLY

These items are all prelubricated, sealed, and require no subsequent lubrication.

## MOTOR BRUSHES

The motor brushes are housed inside of the motor transaxle/assembly. They should be inspected periodically for wear by your authorized Pride Provider.

## CONSOLE, CHARGER, AND REAR ELECTRONICS

- Keep these areas free of moisture.
- Allow these areas to dry thoroughly if they have been exposed to moisture before charging the batteries and operating your PMV again.

## HANDBRAKE

The handbrake lever may require periodic adjustment to maintain proper operation. Contact your authorized Pride Provider for more information.

## FUSE REPLACEMENT



**WARNING! The replacement fuse must exactly match the rating of the old fuse. Failure to use properly rated fuses may cause damage to the electrical system.**

In the event a fuse should cease to work:

1. Remove the fuse by pulling it out of its slot.
2. Examine the fuse to be sure it is blown. See figures 22 and 22A.
3. Insert a new fuse of the proper rating.

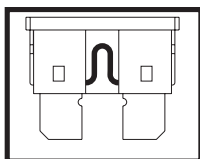

Figure 22. Working Fuse

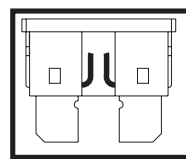

Figure 22A. Blown Fuse (Replace)

# XI. CARE AND MAINTENANCE

## LIGHT BULB REPLACEMENT

The PMV's light bulbs are easily replaceable. Do not use regular automotive-type 12-volt light bulbs; your PMV is equipped with a 24-volt electrical system. Replacement light bulbs can be purchased from your authorized Pride Provider.

*NOTE: Use only 24-volt light bulbs.*

1. Remove the light cover.
2. Gently remove the bulb by pulling it straight out.
3. Insert a new bulb of the same wattage.
4. Replace the light cover.

## NYLON LOCK NUT REPLACEMENT

Any nylon insert lock nut removed during the periodic maintenance, assembly or disassembly of the PMV must be replaced with a new nut. Nylon insert lock nuts should not be reused as it may cause damage to the nylon insert, resulting in a less secure fit. Replacement nylon insert lock nuts are available at local hardware stores or through your authorized Pride Provider.

## STORING YOUR PMV

If you plan on not using your PMV for an extended period of time, it is best to:

1. Fully charge its batteries prior to storage.
2. Disconnect the batteries from the PMV.
3. Store your PMV in a warm, dry environment.
4. Avoid storing your PMV where it will be exposed to temperature extremes.



**WARNING! Always protect batteries from freezing temperatures and never charge a frozen battery. Charging a frozen battery may result in damage to the battery.**

Batteries that are regularly and deeply discharged, infrequently charged, stored in extreme temperatures, or stored without a full charge may be permanently damaged, causing unreliable performance and limited service life. It is recommended that you charge the PMV batteries periodically throughout periods of prolonged storage to ensure proper performance.

You may wish to place several boards under the frame of your PMV to raise it off of the ground during periods of prolonged storage. This takes the weight off the tyres and reduces the possibility of flat spots developing on the areas of the tyres contacting the ground.

## DISPOSAL OF YOUR PMV

Your PMV must be disposed of according to applicable local and national statutory regulations. Contact your local waste disposal agency or authorized Pride Provider for information on proper disposal of packaging, metal frame components, plastic components, electronics, and batteries.



# XII. WARRANTY

## THREE-YEAR LIMITED WARRANTY

For three (3) years from the date of purchase, Pride will repair or replace at our option to the original purchaser, free of charge, any of the following parts found upon examination by an authorized representative of Pride to be defective in material and/or workmanship:

### Structural frame components, including:

- Main Frame
- Fork
- Seat Post
- Tiller Frame

## THREE-YEAR PRORATA WARRANTY

Three-year prorata drivetrain warranty, including:

- Transaxle
- Motor Brake (electronic function ONLY)
- Brake

These components will be prorated on the following schedule:

- First year: 100% replacement of parts cost
- Second year: 67% replacement of parts cost
- Third year: 50% replacement of parts cost

*NOTE: If there is an increase in the operational noise level in the transaxle, the warranty does not apply. An increase in operational noise level usually occurs due to abusive and excessive strain on the PMV.*

## ONE-YEAR LIMITED WARRANTY

For one (1) year from the date of purchase, Pride will repair or replace at our option to the original purchaser, free of charge, any of the following parts found upon examination by an authorized representative of Pride to be defective in material and/or workmanship:

- Bearings
- Bushings
- Rubber Components
- Plastic components except body

### Also, electronic assemblies including:

- Electronic Controllers
- Chargers
- Harnesses
- Any other electrical subassembly

## SIX-MONTH WARRANTY

The battery is covered by a separate six-month warranty, provided by the battery manufacturer. The batteries are not warranted by Pride.

## RECONDITIONED UNITS WARRANTY

All reconditioned units are covered by a six-month warranty from Pride effective from the date of purchase.

## WARRANTY EXCLUSIONS

This warranty does not extend to those items which may require replacement due to normal wear and tear.

- ABS Plastic shrouds
- Motor brushes
- Upholstery and seating
- Brake Pads
- Tires and tubes
- Fuses/Bulbs

## XII. WARRANTY

- Circumstances beyond the control of Pride
- Labor, service calls, shipping, and other charges incurred for repair of the product, unless specifically authorized, IN ADVANCE, by Pride Mobility Products Corporation
- Repairs and/or modifications made to any part without specific consent from Pride

**Exclusions also include components with damage caused by:**

- Contamination
- Abuse, misuse, accident, or negligence
- Battery fluid spillage or leakage
- Commercial use, or use other than normal
- Improper operation, maintenance, or storage

*NOTE: Gradual deterioration in performance because the battery has been left in a discharged state, left in cold conditions for an extended period of time, or worn out through heavy use is not covered.*

### **SERVICE CHECKS AND WARRANTY SERVICE**

Warranty service must be performed by an authorized Pride Provider. Do not return faulty parts to Pride without prior written authorization. All transportation costs and shipping damage incurred while submitting parts for repair or replacement are the responsibility of the purchaser. Please contact your authorized Pride Provider for information on the current cost associated with a service visit.

There is no other express warranty.

### **IMPLIED WARRANTIES**

Implied warranties, including those of merchantability and fitness for a particular purpose, are limited to one (1) year from the date of original purchase and to the extent permitted by law. Any and all implied warranties are excluded. This is the exclusive remedy. Liabilities for consequential damages under any and all warranties are excluded.

Some states do not allow limitations on how long an implied warranty lasts or do not allow the exclusion of limitation of incidental or consequential damages. So, the above limitation or exclusion may not apply to you.

# NOTES



***Pride***  
*Mobility Products Corp.*

*182 Susquehanna Ave.  
Exeter, PA 18643*

*1-800-800-8586*

*[www.pridemobility.com](http://www.pridemobility.com)*

\*I NFMANU2635\*