

Legend

Owner's Manual

ATTENTION:
Please read the content
of your owner's manual
before operating your
scooter.



Legend 3-Wheel Scooter



Legend 4-Wheel Scooter

The Ultimate In Style & Performance[®]

Pride
Mobility Products Corp.

*Exeter, PA
St. Catharines, ON*

1-800-800-8586

www.pridemobility.com

SAFETY GUIDELINES

Please read and follow all instructions in this owner's manual before attempting to operate your Scooter for the first time. If there is anything in this manual you do not understand, or if you require additional assistance for set-up, contact your authorized Pride provider.

Using your Pride product safely depends upon your diligence in following the warnings, cautions, and instructions in this owner's manual. Using your Pride product safely also depends upon your own good judgement and/or common sense, as well as that of your provider, caregiver, and/or healthcare professional. Pride is not responsible for injuries and/or damage resulting from any person's failure to follow the warnings, cautions, and instructions in this owner's manual. Pride is not responsible for injuries and/or damage resulting from any person's failure to exercise good judgement and/or common sense.

The symbols below are used throughout this owner's manual to identify warnings and cautions. It is very important for you to read and understand them completely.



WARNING! Failure to heed the warnings in this owner's manual may result in personal injury.



CAUTION! Failure to heed the cautions in this owner's manual may result in damage to your Scooter.

CONTENTS

I. INTRODUCTION	4
II. SAFETY	6
III. EMI/RFI	15
IV. SPECIFICATIONS	17
V. YOUR LEGEND	19
VI. BATTERIES AND CHARGING	23
VII. OPERATION	27
VIII. COMFORT ADJUSTMENTS	29
IX. DISASSEMBLY AND ASSEMBLY	32
X. OPTIONAL ACCESSORIES	35
XI. BASIC TROUBLESHOOTING	36
XII. CARE AND MAINTENANCE	38
XIII. WARRANTY	40

I. INTRODUCTION

Welcome to Pride Mobility Products Corporation (Pride). Congratulations on the purchase of your new Pride Scooter. Your scooter design combines the most advanced state-of-the-art components with modern, attractive styling. We are certain that the design features and trouble-free operation will add convenience to your daily living and ensure complete satisfaction.

At Pride, your safety is important to us. Please read and follow all of the instructions in this manual before you attempt to operate your scooter for the first time. These instructions were produced for your benefit. Your understanding of these instructions is essential for the safe operation of your new Pride Scooter.

Pride is not liable for damage to property or personal injury arising out of the unsafe use of a Pride Scooter. Pride is also not liable for any property damage or personal injury arising out of the failure of any person and/or user to follow the instructions and recommendations set forth in this manual or any other instructions or recommendations contained in other scooter related literature issued by Pride or contained on the Pride Scooter itself.

This owner's manual is compiled from the latest specifications and product information available at the time of publication. We reserve the right to make changes as they become necessary. Any changes to our products may cause slight variations between the illustrations and explanations in this manual and the product you have purchased.

If you experience any problems with your scooter that you are not able to solve, or if you do not feel capable of safely following any of the instructions and/or recommendations contained in this manual, please contact your authorized Pride Provider for assistance.

Once you understand how to operate and take care of your scooter, we are certain that it will give you years of trouble-free service and enjoyment.

Information Exchange

We want to hear your questions, comments, and suggestions regarding this manual. We would also like to hear about the safety and reliability of your new Pride Scooter, and the service you received from your authorized Pride Provider.

Please notify us of any change of address so we can keep you apprised of important information regarding safety, new products, and new options that can increase your ability to use and enjoy your Pride Scooter. Please feel free to write us at the address below:

Pride Mobility Products Corporation
Attn: Customer Care Department
182 Susquehanna Avenue
Exeter, PA 18643-2694

customercare@pridemobility.com
1-800-424-8205

I. INTRODUCTION

Pride Owners Club

As a Pride product owner, you are invited to register your product's warranty and enroll in the Pride Owners Club. You may do so by filling out and returning your enclosed registration card or by visiting Pride's web site at www.pridemobility.com. As a registered member, each time you visit our site you will have access to the most interactive and honest educational venue available today for people with mobility needs, their families, and friends.

From our home page, click on the button that reads "Owners Club" to enter a page dedicated to current and potential Pride product owners. You will gain access to interviews, stories, recreation ideas, daily living tips, product and funding information, and interactive message boards. Message boards invite you to speak with other Pride customers as well as Pride representatives who are available to assist you with any questions or concerns you may have.

My Authorized Pride Provider Is:

Name: _____

Address: _____

Phone Number: _____

Quick Reference Information:

Scooter Model: _____

Serial Number: _____

Purchase Date: _____

NOTE: If you ever lose or misplace your product registration card or this owner's manual, contact us and we will be glad to send you a new one immediately.

II. SAFETY

GENERAL



WARNING! Do not operate your new scooter for the first time without completely reading and understanding this owner's manual.

Your Scooter is a state-of-the-art life-enhancement device designed to increase mobility. Pride provides an extensive variety of products to best fit the individual needs of the scooter user. Please be aware that the final selection and purchasing decision regarding the type of scooter to be used is the responsibility of the scooter user who is capable of making such a decision and his/her healthcare professional (i.e., medical doctor, physical therapist, etc.).

The contents of this manual are based on the expectation that a mobility device expert has properly fitted the scooter to the user and has assisted the prescribing healthcare professional and/or the authorized Pride Provider in the instruction process for the use of the product.

There are certain situations, including some medical conditions, where the scooter user will need to practice operating the scooter in the presence of a trained attendant. A trained attendant can be defined as a family member or care professional specially trained in assisting a scooter user in various daily living activities.

As you begin using your scooter during daily activities, you will probably encounter situations in which you will need some practice. Simply take your time and you will soon be in full and confident control as you maneuver through doorways, on and off lifts, up and down ramps, and over moderate terrain.

Below are some precautions, tips, and other safety considerations that will help the user become accustomed to operating the scooter safely.

MODIFICATIONS

Pride has designed and engineered your scooter to provide maximum mobility and utility. A wide range of accessories is available from your authorized Pride Provider to further customize your scooter to better suit your needs and/or preferences. However, under no circumstances should you modify, add, remove, or disable any feature, part, or function of your scooter.



WARNING! Do not modify your scooter in any way not authorized by Pride. Unauthorized modifications may result in personal injury and/or damage to your scooter.

REMOVABLE PARTS



WARNING! Do not attempt to lift or move your scooter by any of its removable parts. Personal injury and damage to the scooter may result.

ELECTROMAGNETIC FIELDS

Your scooter's road performance features may be influenced by electromagnetic fields caused by cellular telephones or other radiating devices, such as hand-held radios, radio and television stations, wireless computer links, microwave sources, and paging transmitters. Learn more about this topic in III. "EMI-RFI."

II. SAFETY

PRE-RIDE SAFETY CHECK

Get to know the feel of your scooter and its capabilities. Pride recommends that you perform a safety check before each use to make sure your scooter operates smoothly and safely. For details on how to perform these necessary inspections, see XII. "Care and Maintenance."

Perform the following inspections prior to using your scooter:

- Check for proper tire inflation (if equipped with pneumatic tires).
- Check all electrical connections. Make sure they are tight and not corroded.
- Check all harness connections. Make sure they are secured properly.
- Check the brakes.
- Check battery charge.

If you discover a problem, contact your authorized Pride Provider for assistance.

TIRE INFLATION

If your scooter is equipped with pneumatic tires, you should check or have the air pressure checked at least once a week. Proper inflation pressures will prolong the life of your tires and help ensure the smooth operation of your scooter.



WARNING! It is critically important that 30-35 psi tire pressure be maintained in pneumatic tires at all times. Do not underinflate or overinflate your tires. Low pressure may result in loss of control, and overinflated tires may burst. Failure to maintain 30-35 psi tire pressure in pneumatic tires at all times may result in tire and/or wheel failure, causing serious personal injury and/or damage to your scooter.

WARNING! Inflate your scooter tires from a regulated air source with an available pressure gauge. Inflating your tires from an unregulated air source could overinflate them, resulting in a burst tire and/or personal injury.

WEIGHT LIMITATIONS

Your scooter is rated for a maximum weight capacity. Refer to the specifications table for information.



WARNING! Exceeding the weight capacity voids your warranty and may result in personal injury and damage to your scooter. Pride will not be held responsible for injuries and/or property damage resulting from failure to observe weight limitations.

WARNING! Do not carry passengers on your scooter. Carrying passengers may result in personal injury and/or property damage.

INCLINE INFORMATION

More and more buildings have ramps with specified degrees of inclination, designed for easy and safe access. Some ramps may have turning switchbacks (180-degree turns) that require you to have good cornering skills on your scooter.

- Proceed with extreme caution as you approach the downgrade of a ramp or other incline.
- Take wide swings with your scooter around any tight corners. If you do that, the scooter's rear wheels will follow a wide arc, not cut the corner short, and not bump into or get hung up on any railing corners.
- When driving down a ramp, keep the scooter's speed adjustment set to the slowest speed setting to ensure a safely controlled descent.
- Avoid sudden stops and starts.

II. SAFETY

When climbing an incline, try to keep your scooter moving. If you must stop, start up again slowly, and then accelerate cautiously. When driving down an incline, do so by setting the speed adjustment dial to the slowest setting and driving in the forward direction only. If your scooter starts to move down the incline faster than you anticipated or desired, allow it to come to a complete stop by releasing the throttle control lever. Then push the throttle control lever forward slightly to ensure a safely controlled descent.

WARNING! When climbing an incline, do not zigzag or drive at an angle up the face of the incline. Drive your scooter straight up the incline. This greatly reduces the possibility of a tip or a fall. Always exercise extreme caution when negotiating an incline.



WARNING! Do not drive your scooter across the side of a hill or diagonally up or down a hill; do not stop, if possible, while driving up or down an incline.

WARNING! You should not travel up or down a potentially hazardous incline (i.e., areas covered with snow, ice, cut grass, or wet leaves).

WARNING! When on any sort of an incline or decline, never place the scooter in freewheel mode while seated on it or standing next to it.

WARNING! Even though your scooter is capable of climbing slopes greater than those illustrated in figures 1 and 1A, do not, under any circumstances, exceed the incline guidelines or any other specifications presented in this manual. Doing so could cause instability in your scooter, resulting in personal injury and/or damage to your scooter.

Handicap public access ramps are not subject to government regulation in all countries, and therefore do not necessarily share the same standard percent of slope. Other inclines may be natural or, if man-made, not designed specifically for scooters. Figures 1 and 1A illustrate your scooter's stability and its ability to climb grades under various weight loads and under controlled testing conditions.

These tests were conducted with the scooter's seat in the highest position and adjusted rearward on the seat base to its farthest rearward position. Use this information as a guideline. Your scooter's ability to travel up inclines is affected by your weight, your scooter's speed, your angle of approach to the incline, and your scooter setup.

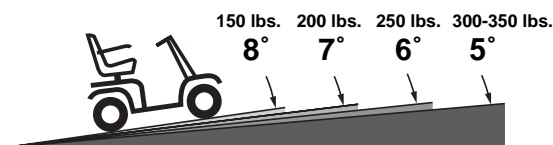

Figure 1. (3-wheel) Maximum Recommended Incline Angles

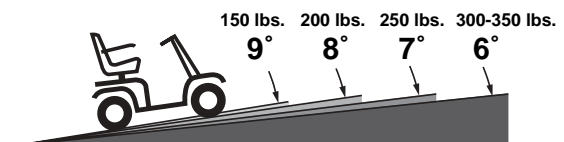

Figure 1A. (4-wheel) Maximum Recommended Incline Angles



WARNING! Any attempt to climb or descend a slope steeper than what is shown in figures 1 and 1A may put your scooter in an unstable position and cause it to tip, resulting in personal injury.



WARNING! Never carry an oxygen tank weighing more than 15 lbs. Never fill the rear basket with contents exceeding 15 lbs.

II. SAFETY

When you approach an incline, it is best to lean forward. See figures 2 and 2A. This shifts the center of gravity of you and your scooter toward the front of the scooter for improved stability.



Figure 2. Normal Driving Position

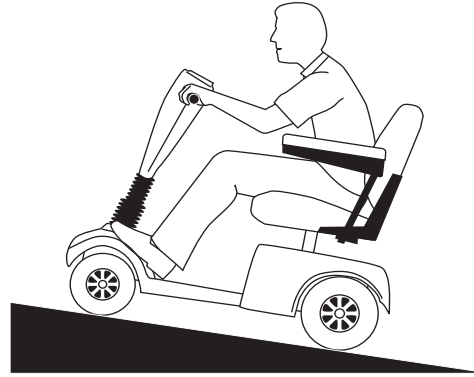

Figure 2A. Increased Stability Driving Position

CORNERING INFORMATION

Excessively high cornering speeds can create the possibility of tipping. Factors which affect the possibility of tipping include, but are not limited to, cornering speed, steering angle (how sharply you are turning), uneven road surfaces, inclined road surfaces, riding from an area of low traction to an area of high traction (such as passing from a grassy area to a paved area – especially at high speed while turning), and abrupt directional changes. High cornering speeds are not recommended. If you feel that you may tip over in a corner, reduce your speed and steering angle (i.e., lessen the sharpness of the turn) to prevent your scooter from tipping.



WARNING! When cornering sharply, reduce your speed. When using your scooter at higher speeds, do not corner sharply. This greatly reduces the possibility of a tip or fall. To avoid personal injury or property damage, always exercise common sense when cornering.

BRAKING INFORMATION

Your scooter is equipped with two powerful brake systems:

1. Regenerative: Uses electricity to rapidly slow the vehicle when the throttle control lever returns to the center/stop position.
2. Disc Park Brake: Activates mechanically after regenerative braking slows the vehicle to near stop, or when power is removed from the system for any reason.

II. SAFETY

OUTDOOR DRIVING SURFACES

Your scooter is designed to provide optimum stability under normal driving conditions—dry, level surfaces composed of concrete, blacktop, or asphalt. However, Pride recognizes that there will be times when you will encounter other surface types. For this reason, your scooter is designed to perform admirably on packed soil, grass, and gravel. Feel free to use your scooter safely on lawns and in park areas.

- Reduce your scooter's speed when driving on uneven terrain and/or soft surfaces.
- Avoid tall grass that can become tangled in the running gear.
- Avoid loosely packed gravel and sand.
- If you feel unsure about a driving surface, avoid that surface.

STREETS AND ROADWAYS



WARNING! You should not operate your scooter on public streets and roadways. Be aware that it may be difficult for traffic to see you when you are seated on your scooter. Obey all local pedestrian traffic rules. Wait until your path is clear of traffic, and then proceed with extreme caution.

NOTE: Safety accessories like fluorescent flags are available to order from your authorized Pride Provider.

STATIONARY OBSTACLES (STEPS, CURBS, ETC.)

WARNING! Do not drive near raised surfaces, unprotected ledges, and/or drop-offs (curbs, porches, stairs, etc.).

WARNING! Do not attempt to have your scooter climb or descend an obstacle that is inordinately high. Serious personal injury and/or damage may result.



WARNING! Do not attempt to have your scooter proceed backward down any step, curb, or other obstacle. This may cause the scooter to tip and cause personal injury.

WARNING! Be sure your scooter is traveling perpendicular to any curb you may be required to ascend or descend. See figures 3 and 3A.

WARNING! Do not attempt to negotiate a curb that has a height greater than 2 in.

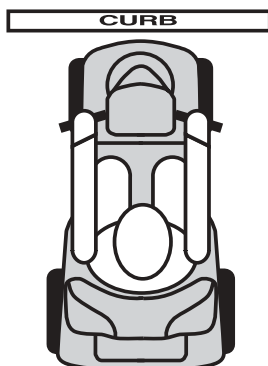

Figure 3. Correct Curb Approach

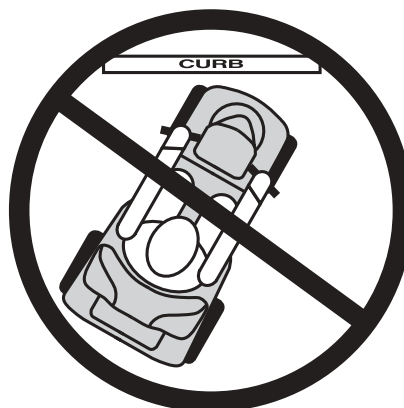

Figure 3A. Incorrect Curb Approach

II. SAFETY

INCLEMENT WEATHER PRECAUTIONS



WARNING! Pride recommends that you do not operate your scooter in icy or slippery conditions or on salted surfaces (i.e., walks or roads). Such use may result in an accident, personal injury, or adversely affect the performance and safety of your scooter.

WARNING! Do not operate or store your scooter where it may be exposed to inclement weather conditions such as rain, snow, mist, and below freezing temperatures (such as storage on an outside car/van lift). Attempting to operate the scooter in such conditions can damage the electronics and potentially result in loss of control.

FREEWHEEL MODE

Your scooter is equipped with a manual freewheel lever that, when pulled up, allows the scooter to be pushed. For more information about how to place your scooter into and out of freewheel mode, see V. “Your Legend.”



WARNING! When your scooter is in freewheel mode, the braking system is disengaged.

- Disengage the drive motors only on a level surface.
- Ensure the key is removed from the key switch.
- Stand behind the scooter to engage or disengage freewheel mode. Never sit on a scooter to do this.
- After you have finished pushing your scooter, always return it to the drive mode to lock the brakes.

Failure to heed the above could result in personal injury and/or damage to your scooter.

An added feature built into the Legend is “push-too-fast” protection which safeguards the scooter against gaining excessive speed while in freewheel mode.

“Push-too-fast” operates differently depending on which of two conditions exists:

- If the key is switched “off” while in freewheel mode, the scooter’s controller activates regenerative braking when the scooter is pushed faster than a maximum threshold which has been preprogrammed. In this case, the controller is acting as a speed governor.
- If the key is switched “on” while in freewheel mode, you will encounter considerable resistance at any speed. This prevents the scooter from gaining unwanted momentum should the manual freewheel lever inadvertently be released while driving the scooter.

II. SAFETY

STAIRS AND ESCALATORS

Scooters are not designed to travel up or down stairs or escalators. Always use an elevator.



WARNING! Do not use your scooter to negotiate steps or escalators. You may cause injury to yourself and to others and/or damage your scooter.

DOORS

- Determine if the door opens toward or away from you.
- Use your hand to turn the knob or push the handle or push-bar.
- Drive your scooter gently and slowly forward to push the door open. Or drive your scooter gently and slowly rearwards to pull the door open.

ELEVATORS

Modern elevators have a door edge safety mechanism that, when pushed, reopens the door(s).

- If you are in the doorway of a elevator when the door(s) begin to close, push on the rubber door edge or allow the rubber door edge to contact the scooter and the door will reopen.
- Use care that pocketbooks, packages, or scooter accessories do not become caught in elevator doors.

LIFT/ELEVATION PRODUCTS

If you will be traveling with your scooter, you may find it necessary to use a lift/elevation product to aid in transportation. Pride recommends that you closely review the instructions, specifications, and safety information set forth by the manufacturer of the lift/elevation product before using that product.



WARNING! Never sit on your scooter when it is being used in connection with any type of lift/elevation product. Your scooter was not designed with such use in mind, and any damage or injury incurred from such use is not the responsibility of Pride.

BATTERIES

In addition to following the warnings below, be sure to comply with all other battery handling information.



WARNING! Scooter batteries are heavy (refer to specifications table). Lifting weight beyond your capacity could result in personal injury. If necessary, get someone physically able to lift the scooter's batteries for you.

WARNING! Battery posts, terminals, and related accessories contain lead and lead compounds. Wash hands after handling.

WARNING! Always protect the batteries from freezing and never charge a frozen battery. Charging a frozen battery may result in personal injury and/or damage to the battery.

WARNING! RED (+) cables must be connected to positive (+) battery terminals/posts. BLACK (-) cables must be connected to negative (-) battery terminals/posts. Failure to connect your battery harnesses in the proper manner may result in personal injury and/or damage to your scooter. REPLACE cables immediately if damaged.

BATTERY DISPOSAL AND RECYCLING

If you encounter a damaged or cracked battery, immediately enclose it in a plastic bag and call your authorized Pride Provider for instructions on disposal. Your authorized Pride Provider will also have the necessary information on battery recycling, which is our recommended course of action.

II. SAFETY

MOTOR VEHICLE TRANSPORT

Currently, there are no standards approved for tie-down systems in a moving vehicle of any type to transport a person while seated in a scooter.

Although your scooter may be equipped with a positioning belt, this belt is not designed to provide proper restraint during motor vehicle transport. Anyone traveling in a motor vehicle should be properly secured in the motor vehicle seat with safety belts fastened securely.



WARNING! Do not sit on your scooter while it is in a moving vehicle. Personal injury and/or property damage may result.

WARNING! Always be sure your scooter and its batteries are properly secured when it is being transported. Failure to do so may result in personal injury and/or damage to your scooter.

PREVENTING UNINTENDED MOVEMENT



WARNING! If you anticipate being seated in a stationary position for an extended period of time, turn off the power. This will prevent unexpected motion from inadvertent throttle control lever contact. Failure to do so may result in personal injury.

GETTING ONTO AND OFF OF YOUR SCOOTER

Getting onto and off of your scooter requires a good sense of balance. Please observe the following safety tips when getting onto and off of your scooter:

- Ensure that your scooter is not in freewheel mode. See V. “Your Legend.”
- Make certain that the seat is locked into place and the key is removed from the key switch.
- The seat armrests of the seat can be flipped up to make getting onto and off of the scooter easier.



WARNING! Position yourself as far back as possible in the scooter seat to prevent the scooter from tipping and causing injury.

WARNING! Avoid using your armrests for weight bearing purposes. Such use may cause the scooter to tip and cause personal injury.

WARNING! Avoid putting all of your weight on the floorboard. Such use may cause the scooter to tip and cause personal injury.

REACHING AND BENDING

Avoid reaching or bending while driving your scooter. When reaching, bending, or leaning while seated on your scooter, it is important to maintain a stable center of gravity and keep the scooter from tipping. Pride recommends that the scooter user determine his/her personal limitations and practice bending and reaching in the presence of a qualified healthcare professional.



WARNING! Do not bend, lean, or reach for objects if you have to pick them up from the floor by reaching down between your knees. Movements such as these may change your center of gravity and the weight distribution of the scooter and cause your scooter to tip, possibly resulting in personal injury. Keep your hands away from the tires when driving.

II. SAFETY

POSITIONING BELTS

Your authorized Pride Provider, therapist(s), and other healthcare professionals are responsible for determining your requirement for a positioning belt in order to operate your scooter safely.



WARNING! If you require a positioning belt to safely operate your scooter, make sure it is fastened securely. Serious personal injury may result if you fall from the scooter.

PRESCRIPTION DRUGS/PHYSICAL LIMITATIONS

The scooter user must exercise care and common sense when operating his/her scooter. This includes awareness of safety issues when taking prescribed or over-the-counter drugs or when the user has specific physical limitations.



WARNING! Consult your physician if you are taking prescribed or over-the-counter medication or if you have certain physical limitations. Some medications and limitations may impair your ability to operate your scooter in a safe manner.

ALCOHOL

The scooter user must exercise care and common sense when operating his/her scooter. This includes awareness of safety issues while under the influence of alcohol.



WARNING! Do not operate your scooter while you are under the influence of alcohol, as this may impair your ability to drive safely.

III. EMI/RFI

EMI/RFI WARNINGS

Laboratory tests performed by the Food and Drug Administration (FDA) have shown that radio waves can cause unintended motion of electric mobility vehicles. Radio waves are a form of electromagnetic energy (EM). When electromagnetic energy adversely affects the operation of an electrical device, that adverse effect is called *Electromagnetic Interference (EMI) or Radio Frequency Interference (RFI)*.

EMI/RFI FREQUENTLY ASKED QUESTIONS (FAQS)

The following FAQs summarize what you should know about EMI/RFI. Use this information to minimize the risk that EMI/RFI will adversely affect your mobility vehicle.

Where do radio waves come from?

Radio waves are emitted from the antennas of cellular phones, mobile two-way radios (such as walkie-talkies and CBs), radio stations, TV stations, amateur radio (HAM) transmitters, wireless computer links, microwave sources, and paging transmitters. Radio waves are a form of electromagnetic energy (EM). EM is more intense closer to transmitting antennas, which are sources of emission. The greater the transmission strength, the greater the concern to electric mobility vehicle users.

If EMI/RFI affects my mobility vehicle, what kind of motion should I expect?

This is difficult to predict. The answer would depend on a number of factors:

- The strength of the radio waves.
- The construction of your particular mobility vehicle.
- The location of your mobility vehicle (whether it is on level ground or on an incline).
- Whether or not your mobility vehicle is in motion.

The motion of any electric mobility vehicle affected by EMI/RFI can be erratic. The mobility vehicle may come to a sudden stop or move in an uncontrolled manner. Also, it is possible for EMI/RFI to release the brakes of an electric mobility vehicle. Some intense EMI/RFI can even damage the control system components of an electric mobility vehicle.

Is there any way to know for certain whether or not radio waves are the cause of any unintended mobility vehicle motion?

Unfortunately, EMI/RFI may be difficult to recognize, because the signals from radio sources are invisible and may be intermittent. However, the FDA recommends that you report all incidents of unintended motion or unintended brake release of your mobility vehicle to its manufacturer and, if possible, determine whether or not there was a radio wave source nearby at the time of the incident.

One precaution you can take against unintended motion of your mobility vehicle is to make certain that you or someone else is not the cause of the unintended motion.

- Turn off your mobility vehicle by removing the key from the key switch when you are getting onto or off of your mobility vehicle.
- Never leave the key in the key switch of an unattended mobility vehicle.
- By following these steps, you greatly reduce the risk of you or anyone else inadvertently bumping the throttle control levers and causing the mobility vehicle to move unintentionally.

Has anyone been injured by the erratic, unintended motion of an electric mobility vehicle?

The FDA has reports of injuries that resulted from uncontrolled motion of electric mobility vehicles, but it is not clear just how many of those injuries were actually caused by EMI/RFI.

III. EMI/RFI

Are all electric mobility vehicles susceptible to EMI/RFI?

Each make and model of electric mobility vehicle differs in its ability to resist EMI/RFI. Every mobility vehicle has a particular level of resistance to EMI/RFI. This resistance is measured in volts per meter (V/m). A higher resistance level offers greater protection against EMI/RFI. In other words, an electric mobility vehicle with a high resistance level is less likely to be affected by a strong radio source than is an electric mobility vehicle with a low resistance level.

What is the FDA doing about the problem?

The FDA has written to electric mobility vehicle manufacturers and requested that those manufacturers test their new mobility vehicle models to be certain that they provide a reasonable degree of resistance against EMI/RFI. The FDA has stated that all newly manufactured electric mobility vehicle models should have a resistance level of at least 20 V/m. This level of resistance provides a reasonable degree of protection against the common sources of EMI/RFI.

The FDA has also requested or recommended that:

- Electric mobility vehicle manufacturers clearly label new products with their resistance level or state that the resistance level is not known.
- The labeling or informational material supplied with new electric mobility vehicles must explain what the resistance level means and warn users about the possibility of EMI/RFI and how to avoid it.
- Electric mobility vehicle manufacturers undertake an educational program to inform electric mobility vehicle users and their caregivers about the problems associated with EMI/RFI and about the actions they can take to minimize the risk of EMI/RFI.
- While there is no exact way to tell if your mobility vehicle is totally safe, an immunity level of 20 V/m is generally achievable and useful. This scooter has been tested and passed at an immunity level of 20 V/m.

What can I do to find out if my mobility vehicle is likely to be affected by EMI/RFI?

If you have had your mobility vehicle for some time and have not experienced any unintended motion, it is not likely that you will have a problem in the future. However, it is always possible that EMI/RFI problems could arise if you are close to a source of radio waves. Therefore, it is very important for you to be alert to this possibility. The mobility vehicle meets or exceeds a resistance level of at least 20 V/m.

What can I do to reduce the risk of my mobility vehicle being affected by EMI/RFI?

Here are some precautions you can take:

- Do not turn on or use hand-held personal communications devices, such as citizens band (CB) radios and cellular phones, while your mobility vehicle is turned on.
- Be aware of nearby radio wave transmitters, such as radio or TV stations and hand-held or mobile two-way radios. Try not to operate your mobility vehicle too close to those transmitters. For example, if you are on an electric mobility vehicle with a resistance level of at least 20 V/m, you should remain at least three feet from a hand-held two-way radio and at least ten feet from a mobile two-way radio.
- Be aware that adding accessories and/or components, or modifying your mobility vehicle in any way, may change its EMI/RFI resistance level and may make it more susceptible to interference from radio wave sources.

What should I do if my mobility vehicle moves unexpectedly?

If unintended motion or unintended brake release occurs, turn off your mobility vehicle (by removing the key) as soon as it is safe to do so.

If my mobility vehicle moves unintentionally, where should I report the incident?

Call the Pride Customer Care at 1-800-424-8205 to report the incident.

IV. SPECIFICATIONS

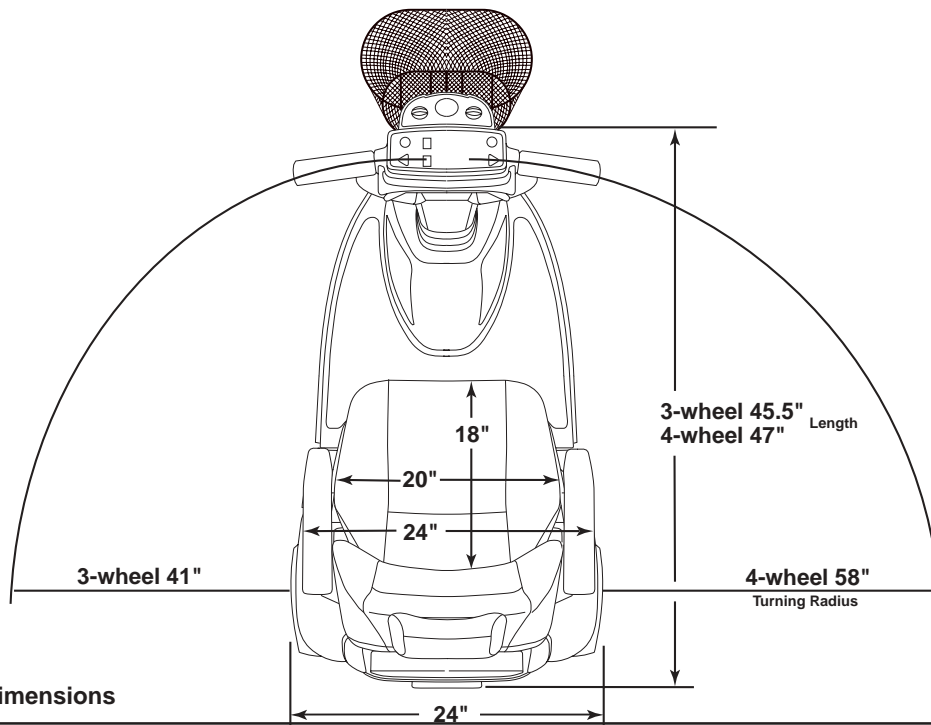
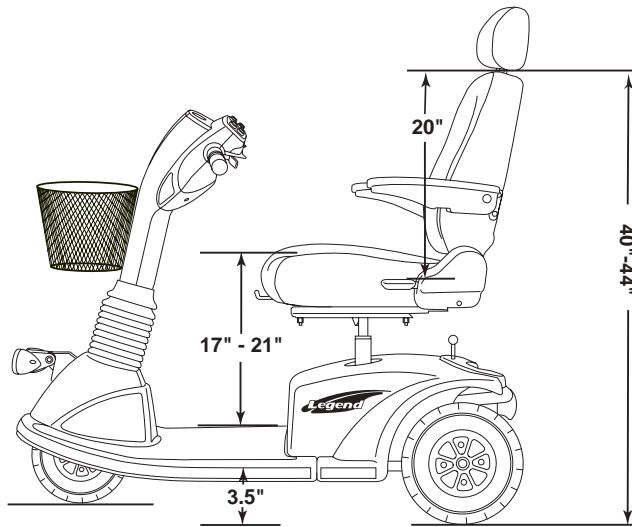

Figure 4. Legend Dimensions

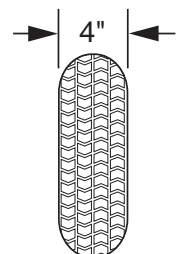
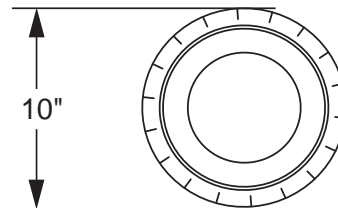
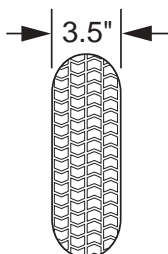
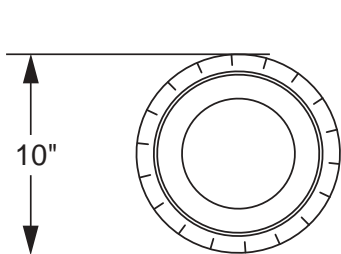

Figure 4A. Legend Front Tire Dimensions

Figure 4B. Legend Rear Tire Dimensions

IV. SPECIFICATIONS

Model Numbers	3-wheel:SC3000 , 4-wheel:SC3400
Available Colors	Painted: Champagne (Standard)**
Overall Length	3-wheel: 45.5 in., 4-wheel: 47 in.
Overall Width	24 in.
Total Weight Without Batteries	3-wheel: 157 lbs., 4-wheel: 166 lbs.
Heaviest Piece When Disassembled	Rear frame: 61 lbs.
Turning Radius	3-wheel: 41 in., 4-wheel: 58 in.
Speed (max)	Variable up to 5.75 mph
Range Per Charge*	(With 32 AH batteries) Up to 25 miles
Ground Clearance	3.5 in.
Weight Capacity	350 lbs.
Standard Seating	Type: CRS Deluxe Reclining High Back with headrest and sliders. Dimensions: 18 in. (usable) width x 18 in. depth (usable) x 20 in. height; with headrest 24 in. – 28 in. (usable) Material: Gray vinyl or Gray fabric
Standard Seat Weight	45 lbs.
Drive System	Rear-wheel drive, sealed transaxle with a 24-volt DC motor
Dual Braking System	Electronic, regenerative, and electromechanical
Wheels	Aluminum alloy mags
Tires	Type: pneumatic; front: 3.5 in. x 10 in., rear: 4 in. x 10 in.
Battery Requirements	Two 12-volt deep cycle (AGM, or Gel Cell) Size: U-1, 32 AH
Battery Weight	24.5 lbs. each
Battery Charger	On-board 3-amp charger
Warranty	3-year limited

** Other colors available through special order.

* Varies with user weight, terrain type, battery charge, battery condition, and tire condition.

V. YOUR LEGEND

TILLER CONSOLE

The tiller console houses all of the controls needed to drive your scooter. See figure 5.



WARNING! Do not expose the tiller console to moisture. In the event that the tiller console does become exposed to moisture, do not attempt to operate your scooter until the tiller console has dried thoroughly.

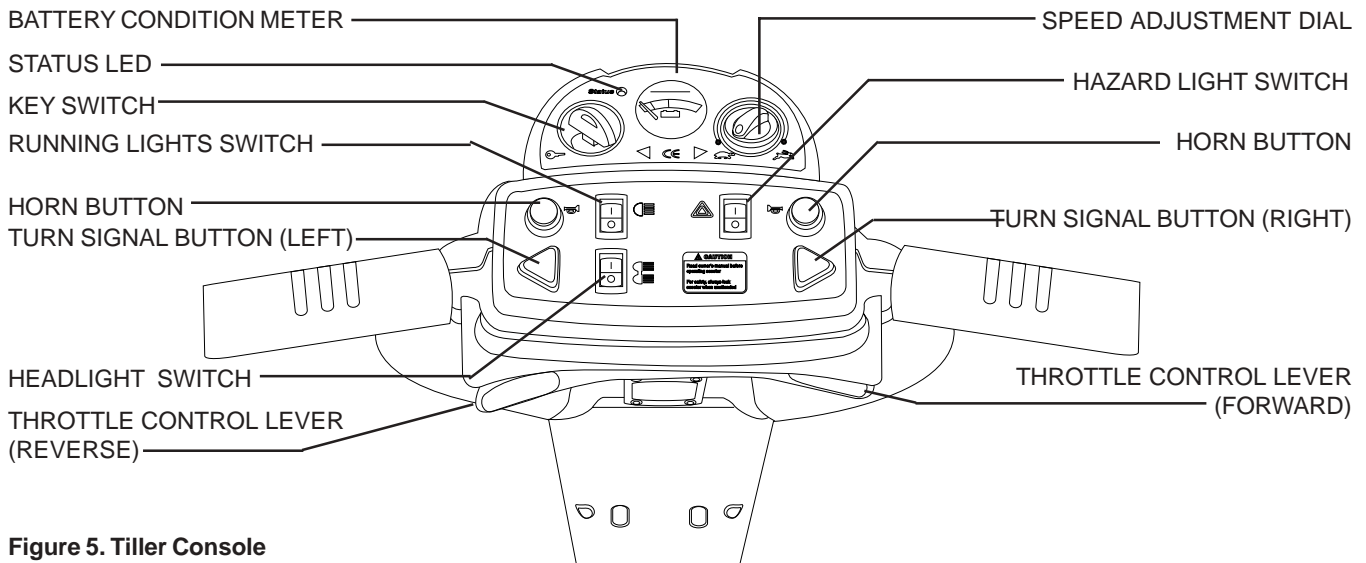

Figure 5. Tiller Console

Key Switch

- Insert the key into the key switch and turn it clockwise to power up (turn on) your scooter.
- Turn the key counterclockwise to power down (turn off) your scooter.



WARNING! If the key is turned to the off position while your scooter is in motion, the electronic brakes engage and your scooter will come to an abrupt stop!

Throttle Control Levers

These levers allow you to control the forward speed and the reverse speed of your scooter up to the maximum speed you preset with the speed adjustment dial.

- Place your right hand on the right handgrip and your left hand on the left handgrip.
- Use your right thumb to push the right side of the lever to disengage your scooter's brakes and move forward.
- Release the lever and allow your scooter to come to a complete stop before pushing the other side of the lever to move in reverse.
- When the throttle is completely released, it automatically returns to the center "stop" position and engages your scooter's brakes.

Speed Adjustment Dial

This dial allows you to preselect and limit your scooter's top speed.

- The image of the tortoise represents the slowest speed setting.
- The image of the hare represents the fastest speed setting.

Status LED

The Status LED alerts you to electrical problems that may occur with the Legend. The LED remains constantly lit while your scooter is on. If the Legend develops an electrical problem, the status LED will flash a code. See XI. "Basic Troubleshooting" for diagnostic flash codes.

V. YOUR LEGEND

Running Lights Switch

This switch controls your scooter's front (upper) and rear running lights.

- Toggle the switch forward to turn on your scooter's running lights.
- Toggle the switch back to turn off your scooter's running lights.

Headlight Switch

This switch controls your scooter's front (lower) light.

- Toggle the switch forward to turn on your scooter's front lower light.
- Toggle the switch back to turn off the light.

Horn Button

Your scooter must be turned on for the horn to be operational.

- This button activates a warning horn.
- Do not hesitate to use the warning horn when doing so may prevent accident or injury.

Hazard Lights Switch

This switch activates the 4-way flashers on your scooter.

- Toggle the switch forward to turn on the flashers.
- Toggle the switch back to turn off the flashers.

Turn Signal Buttons

- Press the appropriate turn signal button once to activate it.
- Your scooter's turn signals are timed to shut off automatically.

3-Amp Tiller Console Fuses

These fuses help protect your scooter's front lighting, turn signals, and key switch console systems from receiving an overload of electrical current. The fuses used in your scooter are the same type used in automobiles. See XII. "Care and Maintenance" for fuse replacement.

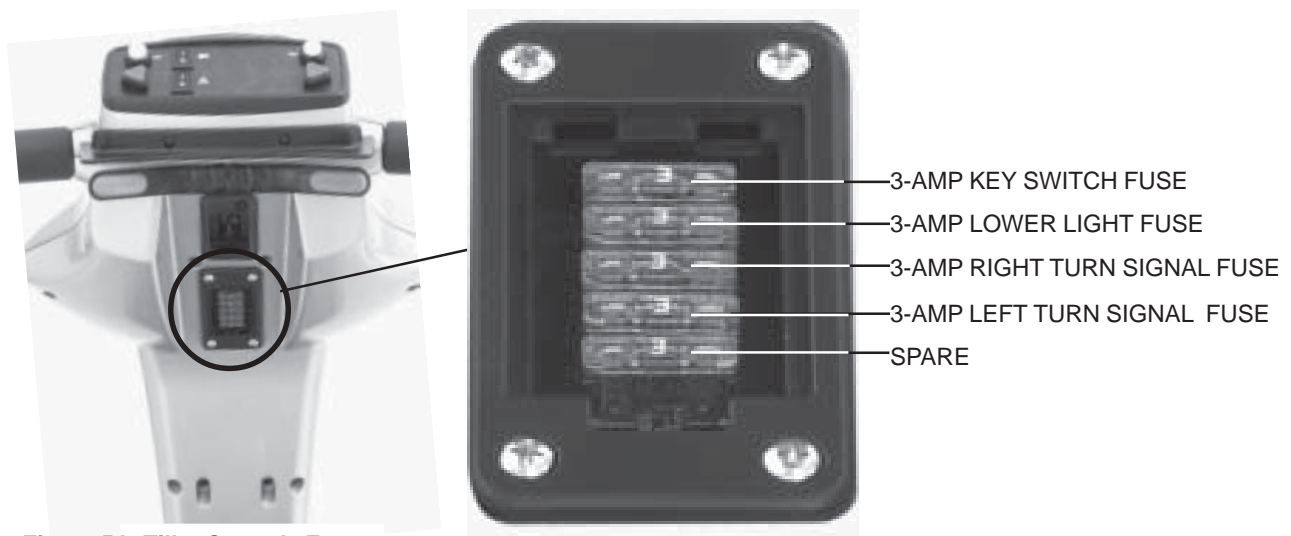

Figure 5A. Tiller Console Fuses

V. YOUR LEGEND

REAR SECTION

The onboard battery charger (not shown), the charger power cord receptacle, the batteries (not shown), the main circuit breaker reset button, the ammeter, the manual freewheel lever, the anti-tip wheels, and the motor/transaxle assembly are located on the rear section of your Legend. See figure 6.

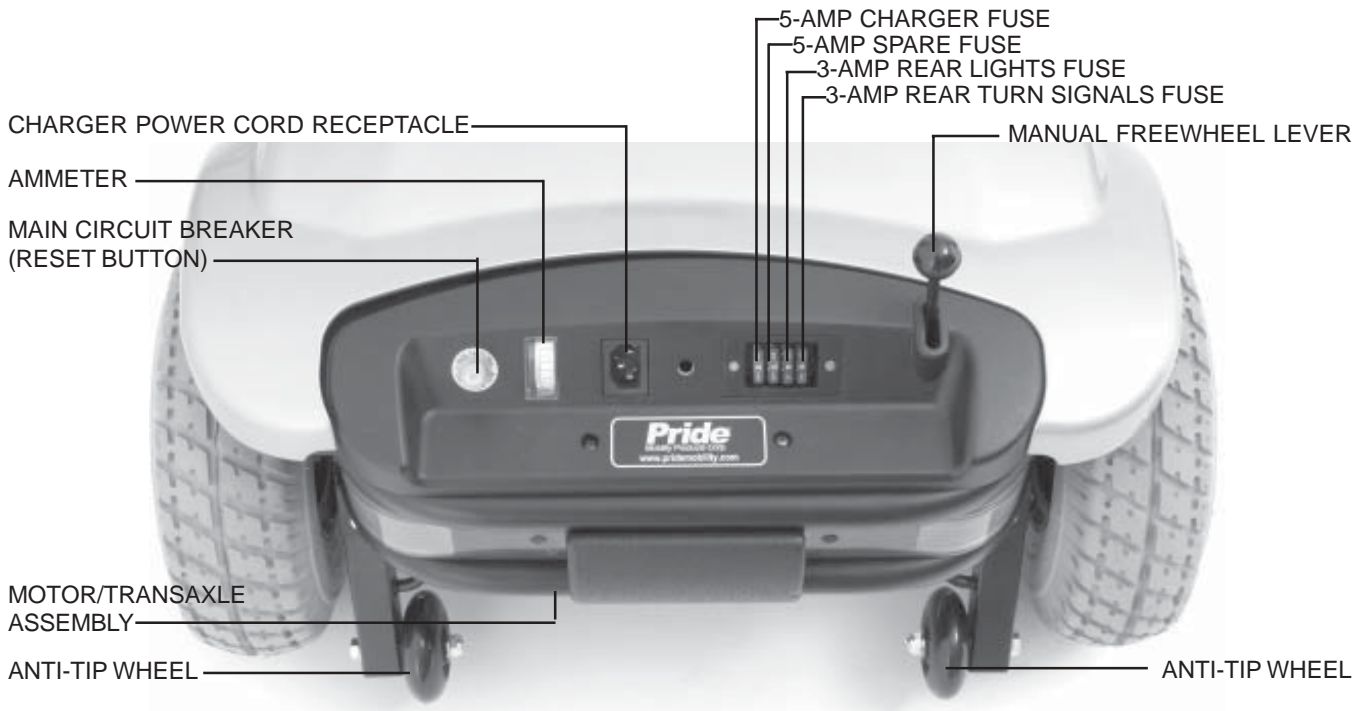

Figure 6. Rear Section

Charger Power Cord Receptacle

The charger power cord plugs into your Legend's battery charger by means of the charger power cord receptacle.

Ammeter

During charging, the ammeter indicates the charging rate, or how hard the charger is working to charge the Legend's batteries. See VI. "Batteries and Charging."

Main Circuit Breaker (Reset Button)

When the voltage in your Legend's batteries becomes low or the scooter is heavily strained because of excessive loads or steep inclines, the main circuit breaker may trip to protect the motor and electronics from damage. See figure 6.

- The main circuit breaker reset button pops out when the breaker trips.
- When the breaker trips, the entire electrical system of your scooter shuts down.
- Allow a minute or two for your Legend's electronics to "rest."
- Push in the reset button to reset the main circuit breaker.
- If the main circuit breaker trips frequently, you may need to charge your batteries more often. You may also need to have your authorized Pride Provider perform a load test on your Legend's batteries.
- If the main circuit breaker trips repeatedly, see your authorized Pride Provider for service.

V. YOUR LEGEND

Manual Freewheel Lever

Whenever you need or want to push your scooter for short distances, you can put it in freewheel mode.

- The manual freewheel lever is located on the end of the motor/transaxle assembly at the right rear of the Legend. See figure 6.
- Remove the key from the key switch.
- Pull up on the manual freewheel lever to disable the drive system and the brake system.
- You may now push your Legend.
- Push down on the manual freewheel lever to reengage the drive and the brake systems and take your scooter out of freewheel mode.



WARNING! When your scooter is in freewheel mode, the braking system is disengaged.

- **Disengage the drive motors only on a level surface.**
- **Ensure the key is removed from the key switch.**
- **Stand behind the scooter to engage or disengage freewheel mode. Never sit on a scooter to do this.**
- **After you have finished pushing your scooter, always return it to the drive mode to lock the brakes.**

Failure to heed the above could result in personal injury and/or damage to your scooter.

NOTE: If the scooter is placed in freewheel mode (manual freewheel lever pulled up) while the key is in the on position, the scooter will not run until the manual freewheel lever is pushed down and the key is turned to the “off” position, then back to the “on” position.

Batteries (Not Shown)

The batteries store electrical energy that powers your Legend. See VI. “Batteries and Charging.”

Anti-Tip Wheels

The anti-tip wheels are an integral and important safety feature of your Legend. Do not, under any circumstances, remove the anti-tip wheels from your Legend.



WARNING! Do not remove the anti-tip wheels or modify your scooter in any way that is not authorized by Pride.

Motor/Transaxle Assembly

The motor/transaxle assembly is an electromechanical unit that converts electrical energy from your Legend’s batteries into the controlled mechanical energy that drives the Legend’s wheels.

Rear Fuses

These fuses help protect your scooter’s rear lighting, turn signals, and charging systems from receiving an overload of electrical current. These fuses are the same type used in automobiles. See XII. “Care and Maintenance” for fuse replacement.

VI. BATTERIES AND CHARGING

Your Legend requires two sealed, maintenance free, 12-volt, deep cycle batteries.

- Charge the batteries prior to using your scooter for the first time.
- Keeping the batteries fully charged will keep your scooter running smoothly.
- Use only the onboard battery charger supplied with your scooter.

READING YOUR BATTERY VOLTAGE

The battery condition meter on the tiller console indicates the approximate strength of your batteries using a color code. Green indicates fully charged batteries, yellow indicates a draining charge, and red indicates that an immediate recharge is necessary. See figure 7. To check the charge, you must first unplug the charger power cord and power up your scooter. To ensure the highest accuracy, the battery condition meter should be checked while operating your scooter at full speed on a dry, level surface.

You can also check the charge using the ammeter located on the rear of the scooter. The charger power cord must be plugged into a standard wall outlet in order to obtain a reading. When the amperage reading is at or near zero amps, the battery charging is complete. See figure 8.



Figure 7. Battery Condition Meter

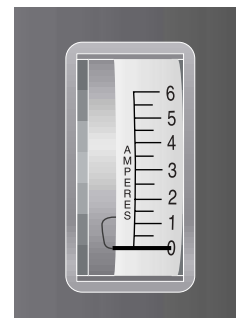

Figure 8. Ammeter Indicates Battery Is Fully Charged

CHARGING YOUR BATTERIES



WARNING! Never use an extension cord to plug in your battery charger. Plug the charger directly into a properly wired standard wall outlet.

WARNING! Removal of the grounding prong can create an electrical hazard. If necessary properly install an approved 3-prong adaptor to an electrical outlet having 2-pronged plug access. Failure to heed could result in personal injury and or property damage.

Follow these easy steps to charge your batteries safely:

1. Position your scooter close to a standard wall outlet.
2. Remove the key from the key switch.
3. Make certain that the manual freewheel lever is in the drive (down) position.
4. Plug the charger power cord into the charger power cord receptacle.
5. Extend the charger power cord and plug it into the wall outlet. It is recommended that you charge your batteries for 8 to 14 hours.
6. When the batteries are fully charged, unplug the charger power cord from the wall outlet and then from the charger power cord receptacle.

NOTE: There is a charger inhibit function on your scooter. The scooter will not run and the battery condition meter will not operate while the batteries are charging.

VI. BATTERIES AND CHARGING

FREQUENTLY ASKED QUESTIONS (FAQS)

How does the charger work?

When your scooter's battery voltage is low, the charger works harder and sends more electrical current to the batteries to bring up their charge. As the voltage of the batteries approaches a full charge, the charger sends less and less electrical current to the batteries. When the batteries are fully charged, the current sent to them from the charger is at nearly zero amperage. Therefore, when the charger is plugged in, it maintains the charge on your scooter's batteries, but does not overcharge them. We do not recommend that you charge your scooter's batteries for more than 24 consecutive hours.

What if the scooter's batteries won't charge?

- Be sure the battery cables are connected properly.
- Ensure both ends of the charger cord are inserted fully.

Can I use a different charger?

For the safest, most efficient and balanced charging of your scooter's batteries, we prefer and highly recommend the simultaneous charging of both batteries by use of the onboard battery charger.

How often must I charge the batteries?

Two major factors must be considered when deciding how often to charge your scooter's batteries:

- All day scooter use on a daily basis.
- Infrequent or sporadic scooter use.

With these considerations in mind, you can determine just how often and for how long you should charge your scooter's batteries. We designed the onboard charger so that it will not overcharge your scooter's batteries (do not charge them for more than 24 consecutive hours). However, you may encounter some problems if you do not charge your batteries often enough and if you do not charge them on a regular basis. Following the five guidelines below will provide safe and reliable battery operation and charging.

- If you use your scooter daily, charge its batteries as soon as you finish using it for the day. Your scooter will be ready each morning to give you a "full day" of service. We recommend that you charge your scooter's batteries for 8 to 14 hours after daily use.
- If you use your scooter once a week or less, charge its batteries at least once a week for 12 to 14 hours at a time.
- Keep your scooter's batteries fully charged.
- Avoid deeply discharging your scooter's batteries.
- Do not charge your scooter's batteries for more than 24 consecutive hours.

Why do my new batteries seem weak?

Deep-cycle batteries employ a different chemical technology than that used in car batteries, nickel-cadmium batteries (nicads), or in other common battery types. Deep-cycle batteries are specifically designed to provide power, drain down their charge, and then accept a relatively quick recharge.

What about public transportation?

If you intend to use public transportation while using your scooter, you must contact in advance the transportation provider to determine their specific requirements.

VI. BATTERIES AND CHARGING

How can I get maximum range or distance per charge?

Rarely will you have ideal driving conditions — smooth, flat, hard driving surfaces with no wind or curves. Often, you will face hills, sidewalk cracks, uneven and loosely packed surfaces, curves, and wind. All of these driving conditions affect the distance or running time per battery charge. The following are a few suggestions for obtaining the maximum range per battery charge.

- Always fully charge the batteries prior to your daily use.
- Maintain **30-35 psi** in all of your scooter tires.
- Plan your route to avoid as many hills, cracked, broken, or soft surfaces as possible.
- Limit your baggage weight to essential items.
- Try to maintain an even speed while your scooter is in motion.
- Avoid stop-and-go driving.

What type and size of battery should I use?

We recommend deep-cycle batteries that are sealed and maintenance free. Both AGM and Gel-Cell are deep-cycle batteries that are similar in performance. Do not use wet-cell batteries, which have removable caps.



WARNING! Corrosive chemicals contained in batteries. Use only AGM or Gel-Cell batteries to reduce the risk of leakage or explosive conditions.

NOTE: Sealed batteries are not serviceable. Do not remove the caps.

Use these specifications to reorder deep-cycle batteries:

Type:	Deep-cycle (AGM or Gel-Cell)
Size:	U-1, 32 AH
Voltage:	12 volts each
Amperage:	32 AH (amp hours)

To change a battery in your scooter:



WARNING! Battery posts, terminals, and related accessories contain lead and lead compounds. Wash hands after handling.

1. Remove the seat and the rear shroud. See IX. “Disassembly and Assembly.”
2. Disconnect the battery strap.
3. Disconnect the 2 pin, black and white battery harness from its mating plug. See figure 15 in IX. “Assembly and Disassembly.”
4. Disconnect the battery cables from the battery terminals.
5. Remove the old battery.
6. Place a new battery in the battery well.
7. Connect the red battery cable to the positive (+) battery terminal.
8. Connect the black battery cable to the negative (-) battery terminal.
9. Reconnect the 2 pin, black and white battery harness to its mating plugs.
10. Reconnect the battery strap.
11. Reinstall the rear shroud and seat.

VI. BATTERIES AND CHARGING

BATTERY DISPOSAL AND RECYCLING

If you encounter a damaged or cracked battery, immediately enclose it in a plastic bag and call your authorized Pride Provider for instructions on disposal. Your authorized Pride Provider will also have the necessary information on battery recycling, which is our recommended course of action.

We work closely with our battery manufacturer to provide batteries that best suit your scooter's specific electrical demands. Fresh batteries arrive daily at Pride and are shipped fully charged to our customers. During shipping, the batteries may encounter temperature extremes that may influence their initial performance. Heat diminishes the charge on the battery; cold slows the available power and extends the time needed to recharge the battery.

It may take a few days for the temperature of your scooter's batteries to stabilize and adjust to their new room or ambient temperature.

More importantly, it takes a few charging cycles (a partial drain followed by a full recharge) to establish the critical chemical balance that is essential to a deep-cycle battery's peak performance and long life.

Please follow these steps to properly break in your scooter's new batteries for maximum efficiency and service life.

1. Fully recharge any new battery prior to its initial use. This charging cycle brings the battery up to about 88% of its peak performance level.
2. Operate your new scooter in familiar and safe areas. Drive slowly at first, and do not travel too far from your home or familiar surroundings until you have become accustomed to your scooter's controls and have properly broken in your scooter's batteries.
3. Fully recharge the batteries. They should be at over 90% of their peak performance level.
4. Operate your scooter again.
5. Fully recharge the batteries again.
6. After four or five charging cycles, the batteries are able to receive a charge of 100% of their peak performance level and are able to last for an extended period of time.

How can I ensure maximum battery life?

Fully charged deep-cycle batteries provide reliable performance and extended battery life. Keep your scooter's batteries fully charged whenever possible. Batteries that are regularly and deeply discharged, infrequently charged, or stored without a full charge may be permanently damaged, causing unreliable performance and limited service life.

How should I store my scooter and its batteries?

See XII. "Care and Maintenance."

VII. OPERATION

BEFORE GETTING ONTO YOUR SCOOTER

- Have you fully charged the batteries? See VI. “Batteries and Charging.”
- Is the manual freewheel lever in the drive (down) position? Never leave the manual freewheel lever pulled up unless you are manually pushing your scooter.

GETTING ONTO YOUR SCOOTER

1. Make certain that the key is removed from the key switch.



WARNING! Never attempt to board or exit your scooter without first removing the key from the key switch. This will prevent the scooter from moving if accidental throttle control lever contact is made.

2. Stand at the side of your scooter.
3. Disengage the seat lock lever and rotate the seat until it is facing you.
4. Make certain that the seat is locked securely in position.
5. Position yourself comfortably and securely in the seat.
6. Disengage the seat lock lever and rotate the seat until you are facing forward.
7. Make certain that the seat is locked securely in position.
8. Make certain that your feet are safely on the floorboard.

PRE-RIDE ADJUSTMENTS AND CHECKS

- Is the seat at the proper height? See VIII. “Comfort Adjustments.”
- Is the seat locked securely in place?
- Is the tiller at a comfortable setting and locked securely in place? See VIII. “Comfort Adjustments.”
- Is the key fully inserted into the key switch and turned clockwise to the “on” position?
- Does the scooter’s horn work properly?
- Is your proposed path clear of people, pets, and obstacles?
- Have you planned your route to avoid adverse terrain and as many inclines as possible?

OPERATING YOUR SCOOTER

Keep both hands on the tiller and your feet on the floorboard at all times while operating your scooter. This driving position gives you the most control over your vehicle.

- Set the speed adjustment dial to your desired speed.
- Press your thumb against the appropriate throttle control lever.
- The electromechanical disc park brake automatically disengages and the scooter accelerates smoothly to the speed you preselected with the speed adjustment dial.
- Pull on the left handgrip to steer your scooter to the left.
- Pull on the right handgrip to steer your scooter to the right.
- Move the tiller to the center position to drive straight ahead.
- To stop, slowly release the throttle control lever. The electronic brakes will automatically engage when your scooter comes to a stop.

NOTE: Your scooter’s reverse speed is slower than that of the forward speed you preset with the speed adjustment dial.

VII. OPERATION

GETTING OFF OF YOUR SCOOTER

1. Bring your scooter to a complete stop.
2. **Remove the key from the key switch.**
3. Disengage the seat lock lever and rotate the seat until you are facing toward the side of your scooter.
4. Make certain that the seat is locked securely in position.
5. Carefully and safely get out of the seat and stand to the side of your scooter.
6. You can leave the seat facing to the side to facilitate boarding your scooter next time.

POWER DOWN TIMER FEATURE

Your scooter is equipped with an energy saving auto power down timer feature designed to preserve your scooter's battery life. If you mistakenly leave the key in the key switch and in the "on" position but do not use your scooter for approximately 20 minutes, the scooter's controller shuts down automatically. Although the controller is shut down, power will still be supplied to the scooter's lighting system.

If the power down timer feature takes effect, perform the following steps to resume normal operation.

1. Remove the key from the key switch.
2. Reinsert the key and power up your scooter.

VIII. COMFORT ADJUSTMENTS



WARNING! Remove the key from the key switch before adjusting the tiller or the seat. Never attempt to adjust the tiller or the seat while the scooter is in motion.

TILLER ANGLE ADJUSTMENT

Your scooter is equipped with a pivoting tiller that allows adjustment to several positions from the scooter deck to the furthest forward stop.

1. Lift the tiller adjustment lever. See figure 9.
2. Move the tiller to a comfortable position.
3. Release the tiller adjustment lever to secure the tiller in position.

TILLER ADJUSTMENT
LEVER



Figure 9. Tiller Adjustment

SEAT ROTATION ADJUSTMENT

The seat lock lever locks the seat in one of eight positions. See figure 10.

1. Push forward on the seat lock lever to unlock the seat.
2. Rotate the seat to the desired position.
3. Release the seat lock lever to lock the seat securely in place. If the seat is not locked into position, gently rock the seat back and forth until you hear the lever “click.”

FRONT-TO-BACK SEAT ADJUSTMENT

You can reposition the Legend’s seat forward or rearward to adjust the distance between the seat and the tiller. See figure 10.

1. Move the seat sliding lever outward.
2. While holding the lever out, slide the seat forward or rearward.
3. Release the seat sliding lever once the seat is in the desired position.



Figure 10. Seat Adjustments

VIII. COMFORT ADJUSTMENTS

SEATBACK ADJUSTMENT



WARNING! Do not operate your scooter with the seatback in a reclined position.
WARNING! Always keep your back pressed firmly against the seat back while adjusting it.

To adjust your Legend's reclining seat, perform these steps. See figure 10A.

1. While pulling up on the seatback adjustment lever, lean forward or backward to adjust the seatback.
2. Release the seatback adjustment lever once the seat is in a comfortable riding position.

ARMREST ANGLE ADJUSTMENT

The armrests of your scooter can be adjusted upward or downward. See figure 10B.

- By turning the adjustment dial, the armrest will either raise or lower.

NOTE: The armrests also pivot upward to make getting on and off of your scooter easier.

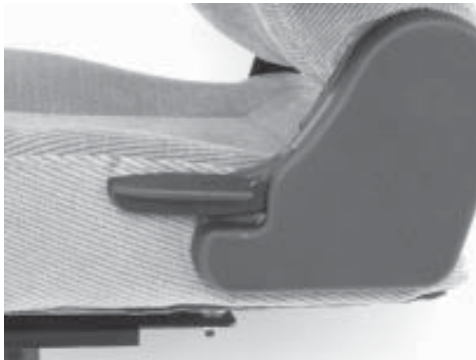

Figure 10A. Seatback Adjustment Lever



Figure 10B. Armrest Angle Adjustment

SEAT HEIGHT ADJUSTMENT

The seat can be repositioned to different heights. See figure 11.

1. Remove the seat and shroud from your Scooter. See IX. "Disassembly and Assembly."
2. Loosen the seat height adjustment bolt-nut and remove it from the bolt. Remove the bolt and washers.
3. Loosen the seat post bolt.
4. Raise or lower the upper seat post to the desired seat height.
5. While holding the upper seat post at that height, match up the locating holes in the upper seat post with those of the lower seat post.
6. With one washer on the seat height adjustment bolt insert it through the locating holes of both the upper and lower seat posts. Reinstall the other washer and bolt-nut and tighten.

NOTE: Ensure both washers have been reinstalled before fully tightening the bolt-nut.

7. Tighten the seat post bolt
8. Reinstall the rear shroud and the seat.

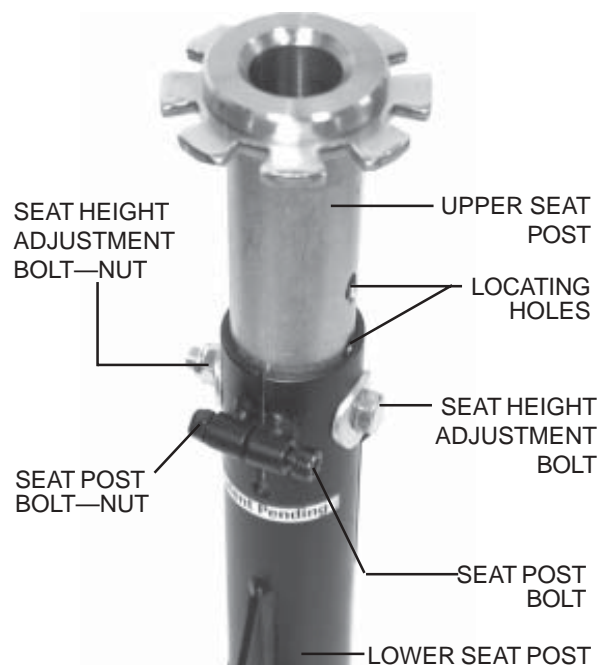

Figure 11. Seat Height Adjustment

VIII. COMFORT ADJUSTMENTS

POWER SEAT (OPTIONAL)

Your Legend may be equipped with a power seat. The power seat actuator is designed to raise or lower the seat automatically with minimal effort on the part of the operator.



WARNING! The power seat is intended for operation only while your scooter is stationary and on a level surface. Its purpose is to aid you in reaching objects.

Strict adherence to the following safety rules is vital to your safety:

- **Do not attempt to raise or lower the seat while in motion!**
- **Operate the power seat only on level ground.**
- **Do not operate your scooter with the power seat elevated.**
- **It is recommended that the scooter be driven only with the seat in the lowest position.**

Raising and lowering the power seat when traveling or when on an incline could cause the scooter to tip over, resulting in serious injury an/or scooter damage. Keep the power seat in its lowest position when traveling or when on an incline.

To operate your power seat:

If the toggle switch is mounted on the right side of the scooter:

1. Push the toggle switch lever forward to raise the seat.
2. Pull the toggle switch lever backward to lower the seat.
3. Release the toggle switch lever when you have attained your desired height.

If the toggle switch is mounted on the left side of the scooter:

1. Push the toggle switch lever forward to lower the seat.
2. Pull the toggle switch lever backward to raise the seat.
3. Release the toggle switch lever when you have attained your desired height.

Ensure your seat is in the lowest position before you attempt to drive your scooter again.

IX. DISASSEMBLY AND ASSEMBLY

DISASSEMBLY

You can disassemble the scooter into seven pieces: the seat, the front section, the rear section, the rear shroud, the basket, and the batteries. See figure 12. Place the scooter in an area where you have sufficient clearance to move the parts around. You need about four or five feet in all directions. You may need assistance to lift some of the scooter components. See IV. "Specifications" for individual component weights.



WARNING! Lifting weight beyond your physical capability may result in personal injury. Ask for assistance when necessary while disassembling or assembling your scooter.



Figure 12. The Legend Disassembled

No tools are required to disassemble or assemble your scooter. Always disassemble or assemble your scooter on a level, dry surface with sufficient room for you to work and move around your scooter. Keep in mind that the disassembled sections of the scooter take up more floor space than the assembled scooter.

1. Place the manual freewheel lever in the drive (down) position.
2. Coil the charger power cord and store it for future use.
3. Push forward on the seat lock lever to unlock the seat; lift the seat up and off the scooter. See figure 13.
4. Gently pull the shroud away from the frame at the bottom and lift it off of the scooter. See figure 14.
5. Disconnect the battery strap.



Figure 13. Removing The Seat



Figure 14. Rear Shroud Removal

IX. DISASSEMBLY AND ASSEMBLY

6. Unplug both black and white 2-pin battery harnesses. See figure 15.
7. Unplug the front-to-rear harness. See figure 16.



CAUTION! Failure to unplug both battery harnesses and the front-to-rear harness prior to separating the front and rear sections could result in permanent damage to the scooter.

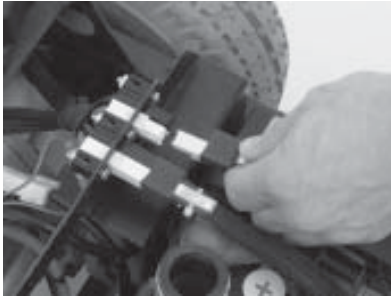

Figure 15. Battery Harnesses

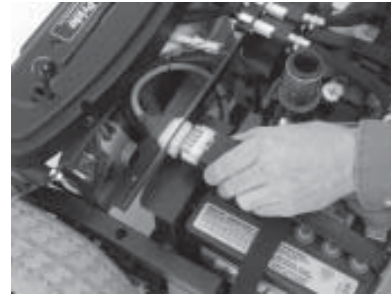

Figure 16. Front-To-Rear Harness

Toggle Latch Release

1. Push in the toggle latch release button while pulling back the toggle latch. See figure 17.
2. Position the toggle latch buckle over the top of the toggle latch. See figure 18.
3. Lower the tiller to the scooter floorboard.

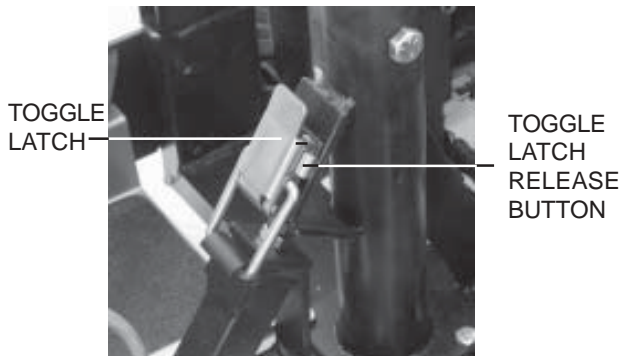

Figure 17. Toggle Latch (Latched)

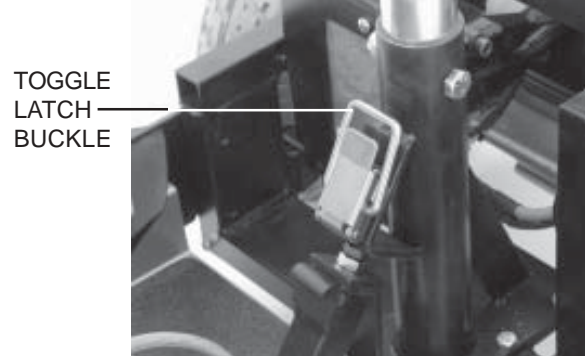

Figure 18. Toggle Latch (Unlatched)

Frame Separation

1. Push back on the seat post to pivot the scooter's rear section backwards until the rear section is standing vertically on its rear bumper. See figure 19.
2. Lift the front section up until the lower pegs are no longer in the slots. See figure 20.
3. Carefully move the front section away from the rear section.

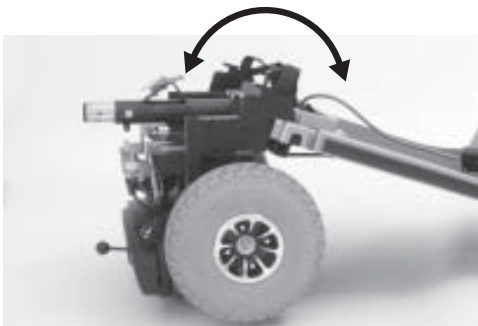

Figure 19. Frame Positioning



Figure 20. Separating The Frame Sections

IX. DISASSEMBLY AND ASSEMBLY

ASSEMBLY

1. Position the front and rear sections of your scooter as shown in figure 21.
2. Align the lower slots of the front section with the corresponding pegs on the front of the rear section.



CAUTION! Position the front-to-rear harness cable so it won't become pinched between the frame halves when pivoting the rear section forward. See figure 22.

3. Holding the seat post, slowly pivot the rear section forward until the curved locking brackets are fully connected onto the top rear pegs. See figure 22.
4. Raise the tiller.
5. Secure the toggle latch. See figure 17.
 - Lower the toggle latch buckle.
 - Push back on the toggle latch so it locks into place.
6. Connect the front-to-rear harness and both battery harnesses.
7. Replace the shroud.
8. Replace the seat, and lock it into place.



Figure 21. Frame Sections



Figure 22. Frame Lockup

X. OPTIONAL ACCESSORIES

OPTIONAL ACCESSORIES

For information concerning these optional accessories, contact your authorized Pride Provider.



• Single Cane/Crutch Holder



• Double Cane/Crutch Holder



• Walker Holder



• Forearm Crutch Holder



• Oxygen Tank Holder



• Rear Basket



• Safety Flag



• Double Crutch Holder



• Quad Cane Holder

XI. BASIC TROUBLESHOOTING

Any electromechanical device occasionally requires some troubleshooting. However, most of the problems that may arise can usually be solved with a bit of thought and common sense. Many of these problems occur because the batteries are not fully charged or because the batteries are worn down and can no longer hold a charge.

DIAGNOSTIC FLASH CODES

The diagnostic flash codes for your scooter are designed to help you perform basic troubleshooting quickly and easily. A diagnostic flash code will flash from the status LED in the event one of the conditions listed below develops.

NOTE: Your scooter will not run unless the flash code condition is resolved and the scooter has been turned off, then turned back on.

FLASH CODE	CONDITION	SOLUTION
(1) ■	Batteries are too low to operate the scooter or the charger is operating.	Charge batteries or unplug the charger power cord from the electrical outlet.
(2) ■■	Motor disconnected.	Check all connections to the motor.
(3) ■■■	Motor wiring fault.	Call your authorized Pride Provider for assistance.
(6) ■■■■■■	Scooter is operating with the charger attached.	Unplug the charger power cord from the charger power cord receptacle.
(7) ■■■■■■■■	Throttle potentiometer fault.	Call your authorized Pride Provider for assistance.
(8) ■■■■■■■■	Internal controller fault.	Call your authorized Pride Provider for assistance.
(9) ■■■■■■■■	Brake fault—your scooter was left in freewheel mode.	Turn the scooter key to the off position, then push the manual freewheel lever to the (down) drive position, and restart your scooter.
(10) ■■■■■■■■	High battery voltage. The batteries have been overcharged and the scooter won't run.	Leave the scooter turned on to drain the batteries to a sufficient level. If the batteries continue to overcharge call your authorized Pride Provider for assistance.

What if all the systems on my scooter seem to be “dead”?

- Make certain that the key is in the “on” position.
- Check that the batteries are fully charged. See VI. “Batteries and Charging.”
- Push in the main circuit breaker reset button. See V. “Your Legend.”
- Make certain that both battery harnesses are firmly connected to the rear electronics module and to the battery terminals. See IX. “Disassembly and Assembly.”
- Make sure that the front-to-rear harness is firmly connected to the rear electronics module. See IX. “Disassembly and Assembly.”
- Check the 3-amp fuse located on the lower portion of the tiller console. See XII. “Care and Maintenance” for fuse replacement.
- Be sure the Power Down Timer feature hasn't been activated.

What if my scooter does not move when I press the throttle control levers?

- When the manual freewheel lever is pulled up, the brakes are disengaged and all power to the motor/transaxle assembly is cut.
- Push down on the manual freewheel lever, turn the scooter off, and then turn the scooter on to return to normal scooter operation.

XI. BASIC TROUBLESHOOTING

What if the main circuit breaker repeatedly trips? See V. “Your Legend.”

- Charge the scooter’s batteries more frequently. See VI. “Batteries and Charging.”
- If the problem continues, have both of your scooter’s batteries load tested by your authorized Pride Provider.
- You may also perform the load test yourself. Battery load testers are available at most automotive parts stores.
- Follow the directions supplied with the load tester.
- See VI. “Batteries and Charging” or IV. “Specifications” for information about your scooter’s battery type.

What if the battery condition meter dips way down and the motor surges or hesitates when I press my scooter’s throttle control lever? (See V. “Your Legend.”)

- Fully charge your scooter’s batteries. See VI. “Batteries and Charging.”
- Have your authorized Pride Provider load test each battery.
- Or, see the previous troubleshooting question for load testing the batteries yourself.

If you experience any problems with your scooter that you are not able to solve, immediately contact your authorized Pride Provider for information, maintenance, and service.

XII. CARE AND MAINTENANCE

Your scooter requires a minimal amount of care and maintenance. If you do not feel confident in your ability to perform the maintenance listed below, you may schedule inspection and maintenance at your authorized Pride Provider. The following areas require periodic inspection and/or care and maintenance.

TIRE PRESSURE

- If equipped with pneumatic tires, always maintain a proper **30-35 psi** tire pressure.



WARNING! It is important that 30-35 psi tire pressure be maintained in pneumatic tires at all times. Do not underinflate or overinflate your tires. Low pressure may result in loss of control, and overinflated tires may burst. Failure to maintain 30-35 psi tire pressure in pneumatic tires at all times may result in tire and/or wheel failure, causing serious personal injury and/or damage to your scooter.

- Regularly inspect your scooter's tires for signs of wear.

EXTERIOR SURFACES

Bumpers, tires, trim, and the tiller boot can benefit from an occasional application of rubber or vinyl conditioner.



WARNING! Do not use a rubber or vinyl conditioner on the scooter's vinyl seat, floorboard, or tire tread. They will become dangerously slippery and result in personal injury and/or damage to your scooter.

BATTERY TERMINAL CONNECTIONS

- Make certain that the terminal connections remain tight and uncorroded.
- The batteries must sit flat in the battery wells.
- The battery terminals should face the rear of the scooter.

WIRING HARNESES

- Regularly check all wiring connections.
- Regularly check all wiring insulation, including the charger power cord, for wear or damage.
- Have your authorized Pride Provider repair or replace any damaged connector, connection, or insulation that you find before using your scooter again.

ABS PLASTIC SHROUDS

- The front tiller shroud, front shroud, and the rear shroud are formed from durable ABS plastic and are coated with an advanced formula urethane paint.
- A light application of car wax will help the shrouds retain their high gloss.

AXLE BEARINGS AND THE MOTOR/TRANSAXLE ASSEMBLY

These items are all prelubricated, sealed, and require no subsequent lubrication.

MOTOR BRUSHES

The motor brushes are housed inside of the motor transaxle/assembly. They should be inspected periodically for wear by your authorized Pride Provider.

XII. CARE AND MAINTENANCE

CONSOLE, CHARGER, AND REAR ELECTRONICS

- Allow these areas to dry thoroughly if they have been exposed to moisture before operating your scooter again.

FUSE REPLACEMENT

In the event a fuse should cease to work:

- Remove the fuse by pulling it out of its slot.
- Examine the fuse to be sure it is blown. See figures 23 and 23A.
- Insert a new fuse of the proper rating.



WARNING! The replacement fuse must exactly match the rating of the new fuse. Failure to use properly rated fuses may cause damage to the electrical system and may result in personal injury.

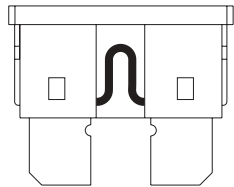

Figure 23. Working Fuse

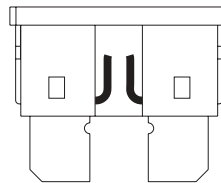

Figure 23A. Blown Fuse (Replace)

REAR LIGHTS

Light bulbs for the rear running lights and turn signals are easily replaceable.

NOTE: Replacement light bulbs can be purchased from your authorized Pride Provider. Use only 24-volt light bulbs.

- Remove the light cover.
- Gently remove the bulb by pulling it straight out.
- Insert a new 24V, 5-watt bulb.
- Replace the light cover.

STORING YOUR SCOOTER

If you plan on not using your scooter for an extended period of time, it is best to:

- Fully charge its batteries prior to storage.
- Disconnect the batteries from the scooter.
- Store your scooter in a warm, dry environment.
- Avoid storing your scooter where it will be exposed to temperature extremes.



WARNING! Always protect batteries from freezing temperatures and never charge a frozen battery. This damages the battery and can cause personal injury.

For prolonged storage, you may wish to place several boards under the frame of your scooter to raise it off of the ground. This takes the weight off the tires and reduces the possibility of flat spots developing on the areas of the tires contacting the ground.

XIII. WARRANTY

THREE-YEAR LIMITED WARRANTY

Three years on all structural frame components; including platform, fork, seat post, and frame.

Three-year prorata drive train warranty; including transaxle, motor, and brake.

- First year: 100% replacement of parts cost
- Second year: 67% replacement of parts cost
- Third year: 50% replacement of parts cost

THREE-YEAR WARRANTY EXCEPTIONS

Transaxle: In cases where there is an increase in the operational noise level, the warranty does not apply. (The increase in operational noise level usually occurs due to abusive and excessive strain on the scooter.)

Motor brake: Three-year warranty for the electrical function of the motor brake. Brake pads are a wear item and are not warranted.

ONE-YEAR LIMITED WARRANTY

For one (1) year from the date of purchase, Pride will repair or replace at our option to the original purchaser, free of charge, any part or electronic component found upon examination by an authorized representative of Pride to be defective in material and/or workmanship.

The battery is warranted by the battery manufacturer (six-month limited warranty). The battery is not warranted by Pride.

Warranty service can be performed by Pride or by an authorized Pride Provider. Do not return faulty parts to Pride without prior consent. All transportation costs and shipping damage incurred while submitting parts for repair or replacement are the responsibility of the original purchaser.

WARRANTY EXCLUSIONS

- ABS plastic shrouds and footrest covers (wear items and not warranted)
- Batteries (the battery manufacturer provides a 6 month limited warranty)
- Tires and tire tubes (wear items and not warranted)
- Upholstery and seating (wear items and not warranted)
- Repairs and/or modifications made to any part of the scooter without specific and prior consent from Pride
- Circumstances beyond the control of Pride
- Damage caused by: battery fluid spillage or leakage, abuse, misuse, accident, or negligence, improper operation, maintenance, or storage, commercial use or use other than normal
- Labor, service calls, shipping, and other charges incurred for repair of the product

There is no other express warranty.

Implied warranties, including those of merchantability and fitness for a particular purpose, are limited to one (1) year from the date of original purchase and to the extent permitted by law. Any and all implied warranties are excluded. This is the exclusive remedy. Liabilities for consequential damages under any and all warranties are excluded.

Some states do not allow limitations on how long an implied warranty lasts or do not allow the exclusion of limitation of incidental or consequential damages. So, the above limitation or exclusion may not apply to you.

NOTES

NOTES

NOTES



Pride
Mobility Products Corp.

182 Susquehanna Ave.
Exeter, PA 18643

1-800-800-8586

www.pridemobility.com